

Measurement and Instrumentation

Transducers and recorders

Overview of ranges	p. 192
Info & advices	p. 194
Digital technology	
TRIAD 2 range	p. 196
MICAR 2 range	p. 210
Analogue technology	
TSP2 range	p. 218
T82 range	p. 222
Industrial transducers	
MODUL'M range	p. 238
Process recorder	
ENERTRACE range	p. 243

1
ENERGY
PERFORMANCE

2
NETWORK
QUALITY

3
MEASUREMENT AND
INSTRUMENTATION



Overview of **ranges**

Measurement and instrumentation **Transducers and recorders**

TRIAD 2 - programmable digital transducers _____

1, 2, 3 or 4 configurable analogue outputs / Class 0.2
1 Ethernet or RS485 digital output



Factory-programmed TRIAD 2
AC quantities
▶ page 196



TRIAD 2 programmable via TRIADJUST 2
AC quantities
▶ page 208



MICAR 2 - programmable multi-function digital transducers _____

2 or 4 configurable analogue outputs / Class 0.2
1 Ethernet or RS485 digital output



Factory-programmed MICAR 2
AC quantities
▶ page 210



MICAR 2 programmable via E.view+
AC quantities
▶ page 216

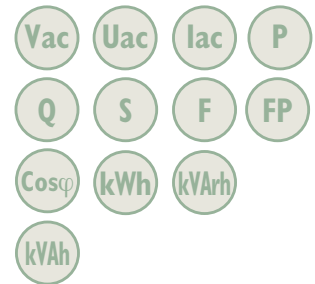

MODUL'M - industrial transducers _____



MTAC
Tachometer
▶ page 239

MTAC-t
Frequency
▶ page 239

ME7, ME3
Process, temperature
▶ page 239-240

MSA4
Analogue outputs
▶ page 240

MES16
Logical inputs/outputs
▶ page 240

MREL5
Extension
▶ page 239

TSP 2 - self-powered analogue transducers 1 analogue output / Class 0.2



TSPU
Voltage measurement
▶ page 218



TSPI
Current measurement
▶ page 218



1

ENERGY
PERFORMANCE

2

NETWORK
QUALITY

T82 - analogue transducers 1 analogue output / Class 0.5



AC
voltage
▶ page 226



AC
current
▶ page 228



AC quantities

Frequency
▶ page 229

Power
factor
▶ page 230

Synchronization
▶ page 231

Power
▶ page 232



DC quantities

DC
voltage
▶ page 234



DC
current
▶ page 235



Physical quantities

Temperature
▶ page 236



Resistance
▶ page 237



3

MEASUREMENT AND
INSTRUMENTATION

ENERTRACE - process recorders



Plug & play
▶ page 243

Transducers measure AC, DC or physical quantities and transmit them as a standard analogue signal (Vdc or mA).



FACTORY-PROGRAMMED OR USER-PROGRAMMABLE?



Factory-programmed

If the specifications of the measurements required are known, a **factory-programmed** transducer can be used.

User-programmable

If the precise specifications of the measurements are not known, choose a **user-programmable** transducer. You can then program it accordingly when the specifications are known and you can modify the settings if these specifications change.

WHICH TRANSFER CURVES SHOULD YOU CHOOSE?

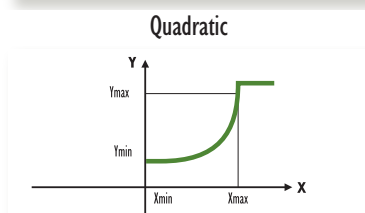
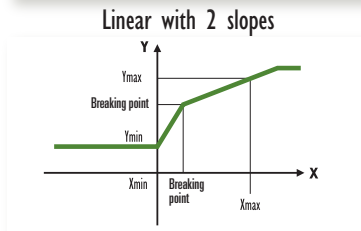
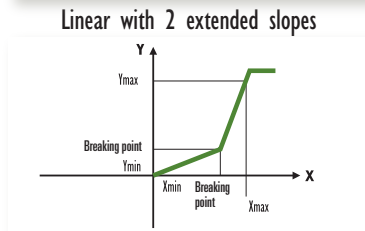
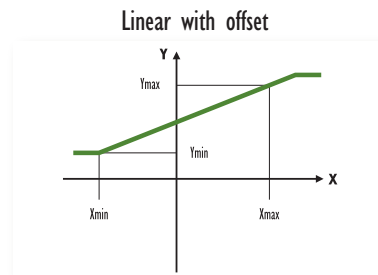
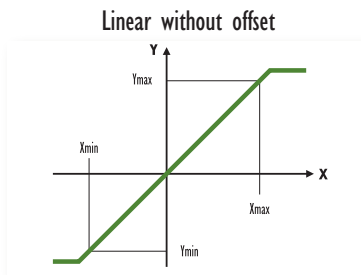
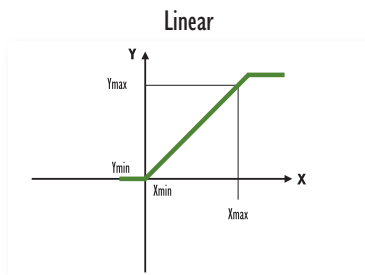

Advantages of analogue outputs

- ▶ **Universality:** the nature of the output signal from the measurement transducer enables quick and easy connection to a wide range of instruments (recorders, controllers, calculators, analogue and digital panel meters, measurement relays, PLCs, RTUs, etc.).
- ▶ **Response time:** the response time of an analogue output enables real-time viewing of all electrical parameters (for example, SCADA application, dispatching, control and monitoring of industrial processes).
- ▶ **Resistance to disturbances:** analogue signals (current outputs in particular) are not significantly affected by electromagnetic disturbances. A single shielded-pair wire enables you to transmit the output signal over very long distances (several hundred meters without signal amplification).
- ▶ **Reliability:** analogue transducer technology offers the advantage of several decades of application and use, benefiting from wide experience in such varied fields as industry, building automation and electrical network supervision (dispatching).

Advantages of programmable transducers

The configuration software associated with transducers enables you to adapt transducer specifications to application needs at all times and stages of the application.

- ▶ **Reduction of stocks and maintenance costs**
A programmable transducer can replace any other product as necessary, helping to reduce stocks for maintenance.
- ▶ **Quickly and easily replaceable products**
Programmability makes it easy to replace products quickly, thus cutting maintenance time.
- ▶ **Adaptable to installation evolutions**
The programmable transducer can be modified at all times, especially in the case of modification of initial specifications or information unavailable at the outset.

Advantages of digital outputs

- ▶ **Remote access for easy maintenance:** with digital outputs, it is possible to create a communicating network so that you can set the products' parameters remotely.
- ▶ **Remote meter-reading:** using the commands available in the ModBus mapping, a transducer can be operated via a digital supervision system and remote-read all the electrical quantities available per product on the same bus.
- ▶ **Extra functions:** the digital outputs on our transducers can be used to access functions which were previously unavailable, such as alarm, date-stamping or energy index functions.

1

ENERGY
PERFORMANCE

2

NETWORK
QUALITY

3

MEASUREMENT AND
INSTRUMENTATION

FOCUS

Accuracy class and IEC 688 standard

The IEC 688 standard defines the accuracy class as the limits of the intrinsic error expressed as a percentage of the output interval.

Example:

For a measurement range of 0 - 1,000 kW, an output interval of 16 mA (output 4-20 mA) and an accuracy class of 0.2, the intrinsic error is:

$$\frac{0.2}{100} \times 16 \text{ mA} = \pm 0.032 \text{ mA}$$

representing a measurement uncertainty of ± 2 kW over the complete measurement range 0 - 1,000 kW.

2010

TRIAD 2 Range

Programmable digital transducers with 1 to 4 analogue outputs
 Programmable accuracy class

Measurement and instrumentation Programmable digital transducers

PRODUCT ADVANTAGES

- + Up to 4 PROGRAMMABLE ANALOGUE OUTPUTS**
- + 4 kV INSULATION**
- + CONFIGURABLE AND MODIFIABLE**
using the TRIADJUST 2 software
- + ADJUSTABLE**
accuracy within Class 0.1 as per IEC 60688
- + ADJUSTABLE RESPONSE TIME**
down to 50 ms
- + DIGITAL OUTPUT**
available as an **OPTION**

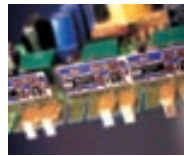

Multi-function, economical instrument with 4 functions in the same casing



Communication, Ethernet RS 485 or optical head



Accessibility and safety: large-dimension terminals
Insulated circuits



Ergonomic: easy mounting on DIN rail or switchboard

► Main specifications

Quantities measured: 1, 2, 3, 4 to be chosen from I, V, U, F, FP, P, Q, S, $\cos\varphi$, φ , φU , φV , $\tan\varphi$
Configuration of TRIAD 2: in factory or by the user with the TRIADJUST 2 software
Accuracy (programmable): Class 0.1 / 0.15 / 0.2 / 0.5 / 1
Current inputs: 1 A and 5 A
Voltage inputs: 100 to 480 V (ph-ph) or $100 / \sqrt{3}$ to 480 / $\sqrt{3}$ V (ph-N)
Transfer curves: linear, 2 slopes or quadratic
Output signals: ± 1 mA, ± 5 mA, ± 20 mA, ± 1 V, ± 10 V
Response time in Class 0.2: 200 ms
Operating frequency: 50 or 60 Hz
Auxiliary power supply with wide dynamic range: 80 to 265 V ac/dc or 19 to 58 V dc
Compliance with CE directive
Digital technology

TRIAD 2

Programmable model

► Factory-programmable

- The transducer delivered is ready to operate and can be connected to the electrical network in order to deliver output signals tailored for your installation.
- To benefit from this, you simply need to know the exact specifications of your electrical installation:
 - Type of network: single-phase, balanced or unbalanced three-phase, 3 or 4 wires.
 - Type of electrical connections.
 - Number of electrical quantities to be measured: 1, 2, 3 or 4.
 - Precise measurement ranges of the input/output quantities to be measured.

Users can modify a factory configuration at any time with the TRIADJUST 2 software if the specifications of the electrical network change.

► Programmable via TRIADJUST 2

- With the TRIADJUST 2 software and one of the 3 communication modes available (Ethernet, RS485 or optical head) you can program all the parameters characterizing a TRIAD 2 transducer.
- To do so, simply choose a model which suits your electrical installation:
 - Type of network: single-phase, balanced or unbalanced three-phase, 3 or 4 wires.
 - Number of analogue outputs required (1, 2 3 or 4).
 - Value of the auxiliary source.
- You are then free to configure the TRIAD 2 transducer delivered as you wish and to print out the stickers corresponding to the parameters programmed.

► Environment and standards

EMC IMMUNITY (standard of reference: IEC 60688, IEC 61326-1, IEC 61000-6-5)	
Shock voltage as per IEC 61000-4-5	2 kV in differential mode 4 kV in common mode
Oscillating wave as per IEC 61000-4-12	1 kV in differential mode 2.5 kV in common mode
Fast electrical transients in bursts as per IEC 61000-4-4	2 kV on power supply 2 kV on inputs/outputs
Electrostatic discharge as per IEC 61000-4-2	8 kV in the air 6 kV in contact
EM radiated field as per IEC 61000-4-3	10 V/m (80 MHz to 3 GHz)
Voltage dips as per IEC 61000-4-11	30% reduction during 20 ms 60% reduction during 1 s
Voltage interruptions as per IEC 61000-4-11	100% reduction during 100 ms 100% reduction during 100 ms

EMC emissions	
Radiated and conducted	As per CISPR11
Climatic specifications (IEC 60068 2-1/2-2/2-30)	
Operating temperature	-10°C to +55°C
Storage temperature	-40°C to +70°C
Relative humidity	≤ 95% to 55°C
Safety specifications (IEC 61010-1)	
Installation category	3
Pollution level	2
Fire resistance	UL94, severity V0
Mechanical specifications (IEC 60068 2-6/2-27/2-29/2-32/2-63)	
Protection rating	IP 20
Mechanical shocks	IEC 60068-2-27
Vibrations	IEC 60068-2-6
Drop test with packaging	NF 0042-1

► Mounting accessories

Model	Reference
Plate mounting for T1xy	ACCT 1007
Plate mounting for T3xy	ACCT 1006

► Casing

Weight	320g (T1xy) / 700g (T3xy)
Mounting	DIN rail 43700 or plate mounting
Connection	Terminals with mobile stirrup clamp with screw for 4 single-wire 6 mm ² conductors or 2 multi-wire 4 mm ² conductors

1

ENERGY
PERFORMANCE

2

NETWORK
QUALITY

3

MEASUREMENT AND
INSTRUMENTATION



TRIAD 2 Range

► Hardware identification

The TRIAD 2 T1xy and T3xy are fully configurable with the TRIADJUST 2 software which allows users to modify the characteristics of their products right up to the last minute.

Programmable digital transducers

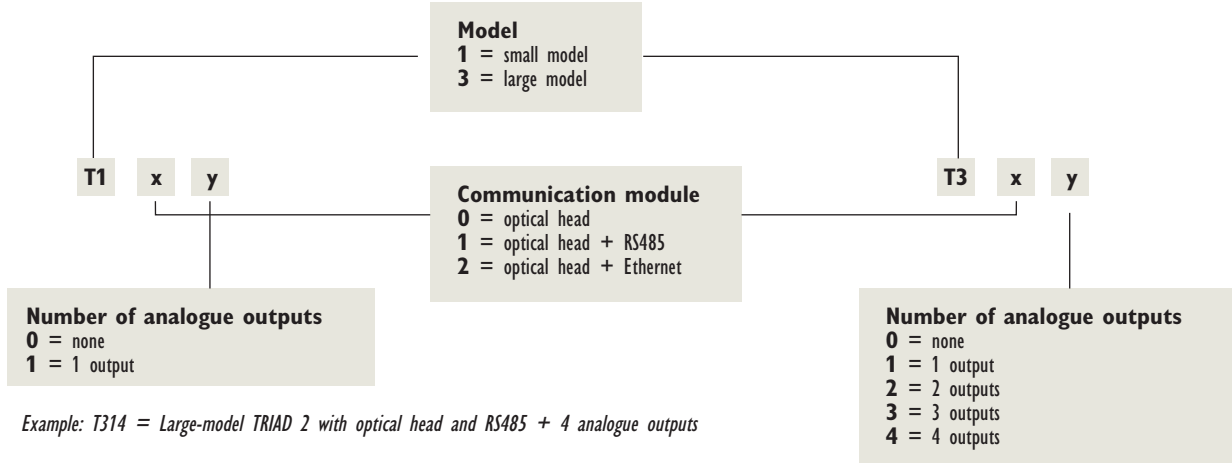

Network	Function	T1xy model	T3xy model
Single-phase	V	•	•
	I	•	•
	F	•	•
	P	•	•
	Q	•	•
	S	•	•
	FP	•	•
	Tanφ	•	•
	Cosφ	•	•
	φ	•	•
Balanced 3-phase, 3 wires	U12, U23, U31	•	•
	I1, I2, I3	•	•
	F	•	•
	Pt	•	•
	Qt	•	•
	St	•	•
	FPt	•	•
	Tanφ	•	•
	Cosφt	•	•
	φt	•	•
Balanced 3-phase, 4 wires	V1, V2, V3	•	•
	U12, U23, U31	•	•
	I1, I2, I3	•	•
	F	•	•
	P1, P2, P3, Pt	•	•
	Q1, Q2, Q3, Qt	•	•
	S1, S2, S3, St	•	•
	FP1, FP2, FP3, FPt	•	•
	Tanφ	•	•
	Cos(φ1, φ2, φ3, φt)	•	•
φ1, φ2, φ3, φt	•	•	
Unbalanced 3-phase, 3/4 wires	V1, V2, V3	•	•
	U12, U23, U31	•	•
	I1, I2, I3	•	•
	F	•	•
	P1, P2, P3, Pt	•	•
	Q1, Q2, Q3, Qt	•	•
	S1, S2, S3, St	•	•
	FP1, FP2, FP3, FPt	•	•
	Tanφ	•	•
	Cos(φ1, φ2, φ3, φt)	•	•
φ1, φ2, φ3, φt	•	•	
φ (U12/U23, U23/U31, U31/U12)	•	•	
φ (V1/V2, V2/V3, V3/V1)	•	•	

TRIAD 2

Programmable model

► Electrical specifications

Voltage input		
Rated value	T1: from 57.7 Vac to 276 Vac max. T3: from 57.7 Vac to 480 Vac max.	
Frequency	50 Hz: 42.5...57.5 Hz 60 Hz: 51...69 Hz	
Max. measured voltage on primary	650 kV (ph-ph)	
Acceptable overloads	T1: 300 Vac permanent - 460 Vac / 10s T3: 520 Vac permanent - 800 Vac / 10s	
Consumption	< 0.2 A	
Input impedance	400 kΩ	
Current inputs		
Rated value	0 to 10 A max.	
Max. measured current on primary	25,000 A	
Acceptable overload	50 In / 1 s	
Consumption	< 0.15 VA	
Auxiliary power supply		
High level	80 / 265 Vac (50/60 Hz) — 80 / 265 Vdc	
Low level	19 / 58 Vdc	
Consumption	High level	Low level
	T1: 8.5 VA max. T3: 20 VA max.	T1: 5 W max. T3: 10 W max.
Analogue outputs		
Rated values	Current	Voltage
	± 1mA, ± 5mA, ± 20mA	± 1 V, ± 10 V
Acceptable resistive load	15 V / I _o ⁽¹⁾	≥ 1 kΩ
Acceptable capacitive load	0.1 μF	0.1 μF
Overrun	1.2 I _o ⁽¹⁾	1.2 U _o ⁽¹⁾
Peak-peak residual wave	± 0.2% of I _o ⁽¹⁾	± 0.2% of U _o ⁽¹⁾
Programmable response time	50 ms — 100 ms — 200 ms — 500 ms — 1 s	
Transfer curve	Linear, 2 slopes or quadratic	

⁽¹⁾ I_o = output current, U_o = output voltage

► Communication

	Optical head	Ethernet	RS485
Connection	USB (PC) Optical (product)	RJ45	2 wires Half-duplex
Protocol	MODBUS RTU mode	MODBUS / TCP RTU mode	MODBUS / JBUS RTU mode
Speed	38,400 baud	10 base T	2,400 to 115,200 baud
Parity	-	-	Even, odd or none
JBUS addresses	-	-	1 to 247
Transmission length	2 m	100 m	1.2 km as EIA 485

► Metrological specifications

Measurements	Accuracy class over measurement range (as per IEC 60688)				
	RT = 50 ms	RT = 100 ms	RT = 200 ms	RT = 500 ms	RT = 1 s
V, U, I, F, P, Q, S, FP, Tanφ, Cosφ, φ, φU, φV	± 1%	± 0.5%	± 0.2%	± 0.15%	± 0.1%

* RT: Response time for F = 50 Hz

** Phase angle between voltages



TRIAD 2 Range

► Electrical connections Single-phase network

Programmable digital transducers
Measurement and instrumentation

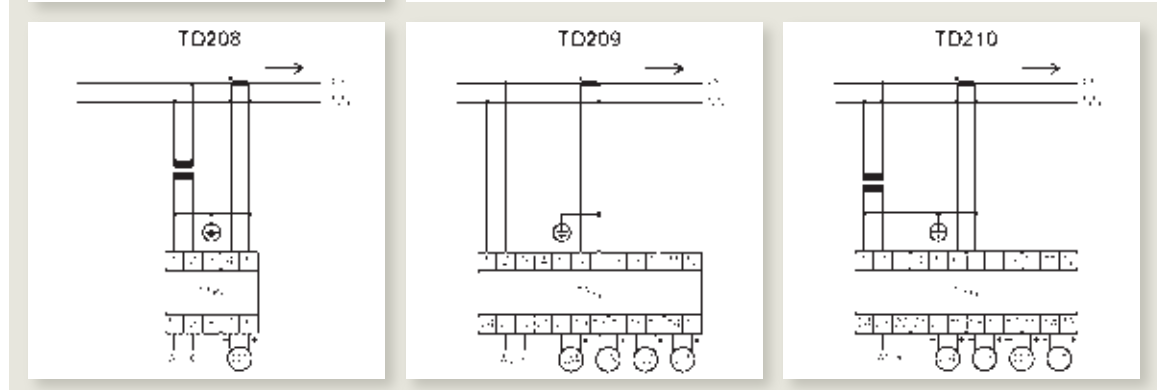
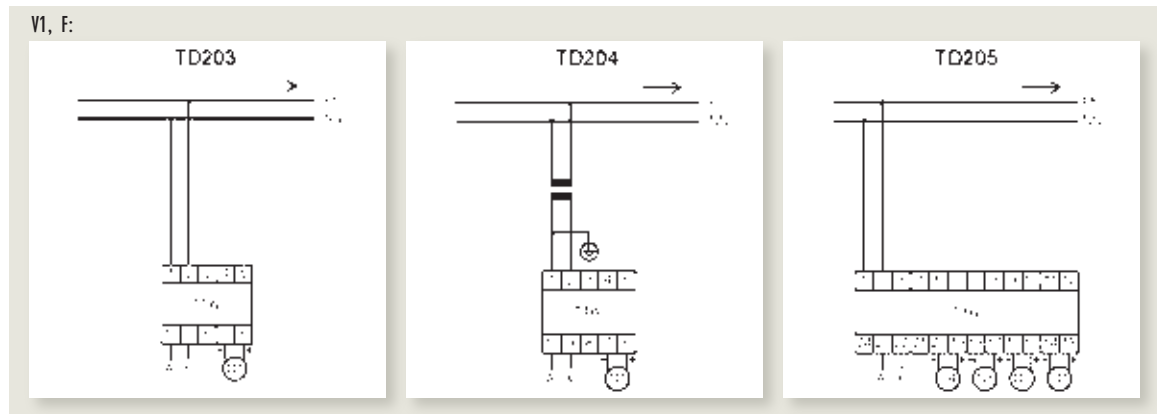
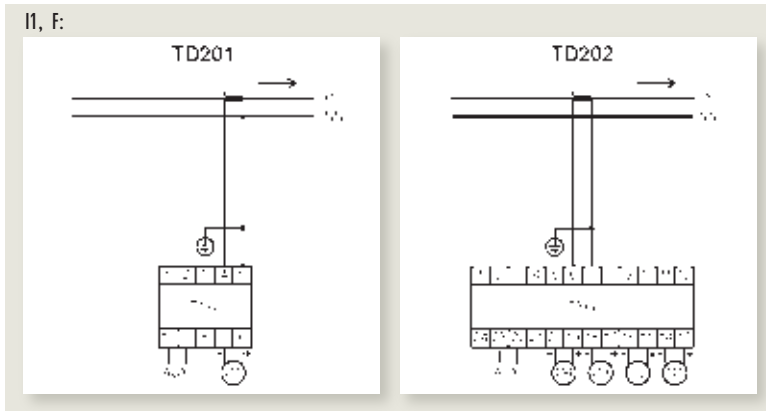

Balanced 3-phase, 3-wire network

U12, U23, U31, F:

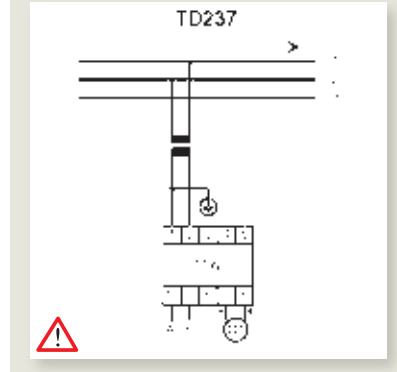
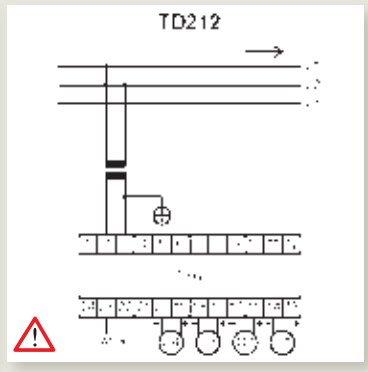
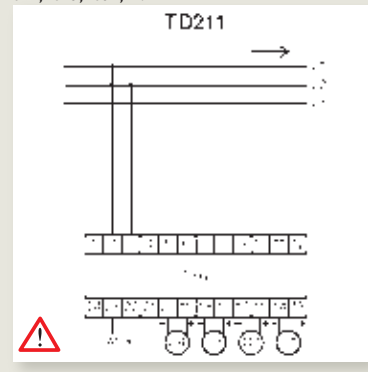

I1, I2, I3, F:

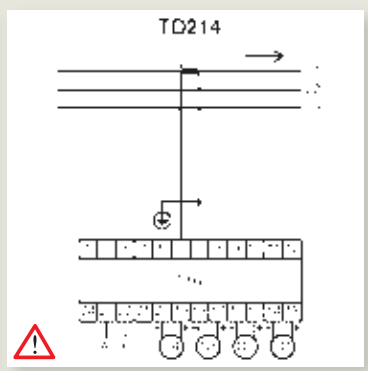
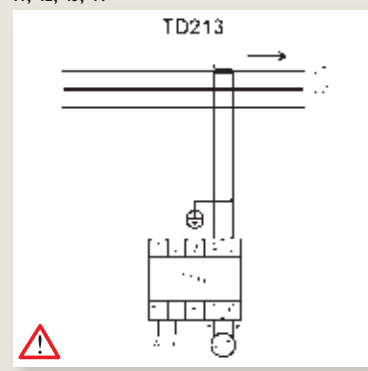

U12, U23, U31, I1, I2, I3, Pt, St, Qt, FPt, F, TANφ, Cosφpt, φpt:

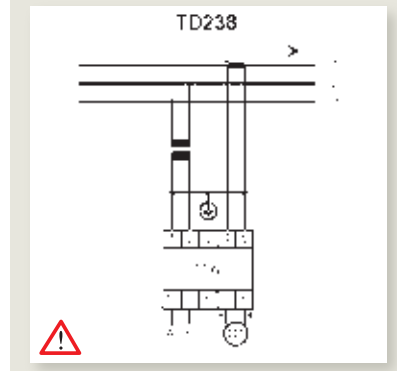
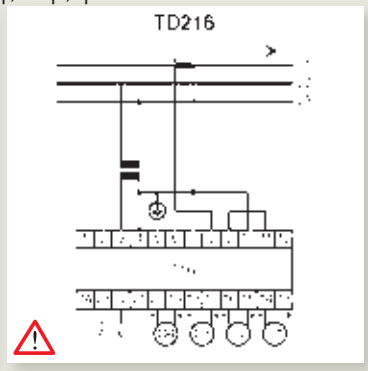
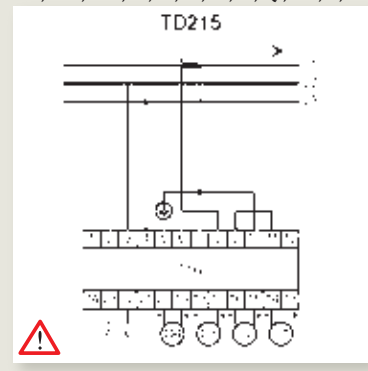

1

ENERGY
PERFORMANCE

2

NETWORK
QUALITY

3

MEASUREMENT AND
INSTRUMENTATION

 Phase rotation authorized



TRIAD 2 Range

Balanced 3-phase, 4-wire network

Programmable digital transducers
Measurement and instrumentation

V1, V2, V3, U12, U23, U31 F:

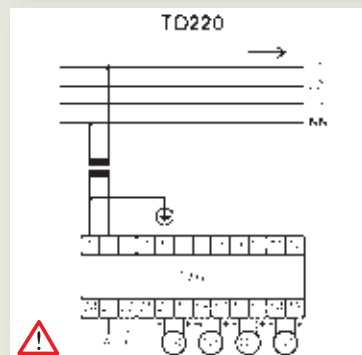
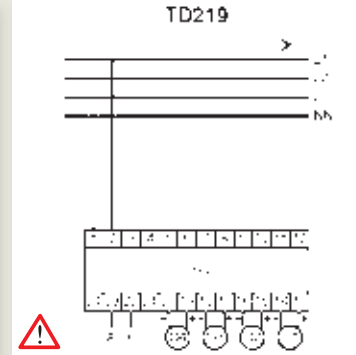
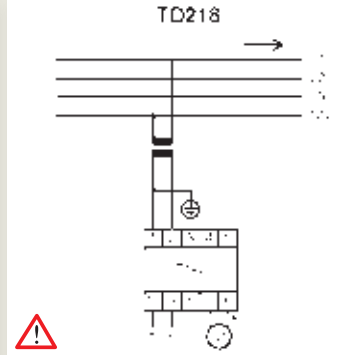
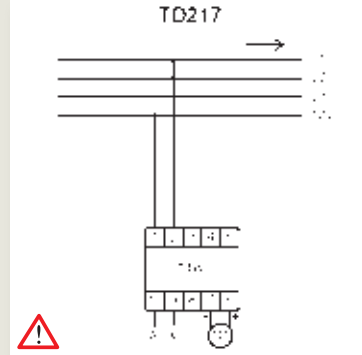

I1, I2, I3, F:

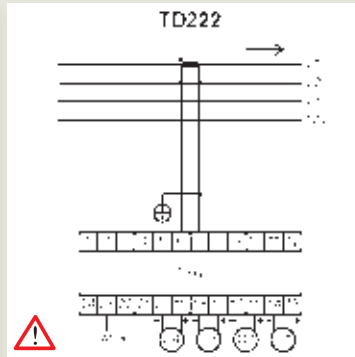
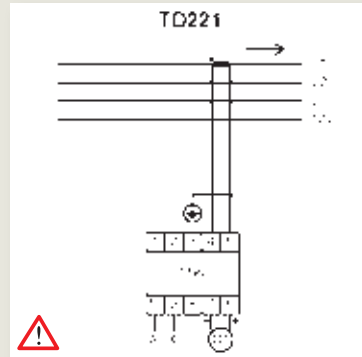

Phase rotation authorized

Balanced 3-phase, 4-wire network (continued)

V1, V2, V3, U12, U23, U31, I1, I2, I3, P1, P2, P3, Pt, S1, S2, S3, St, Q1, Q2, Q3, Qt, FP1, FP2, FP3, FPt, F, TAN φ , Cos φ 1, Cos φ 2, Cos φ 3, Cos φ t, φ 1, φ 2, φ 3, φ t

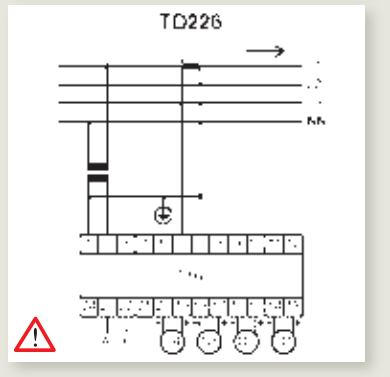
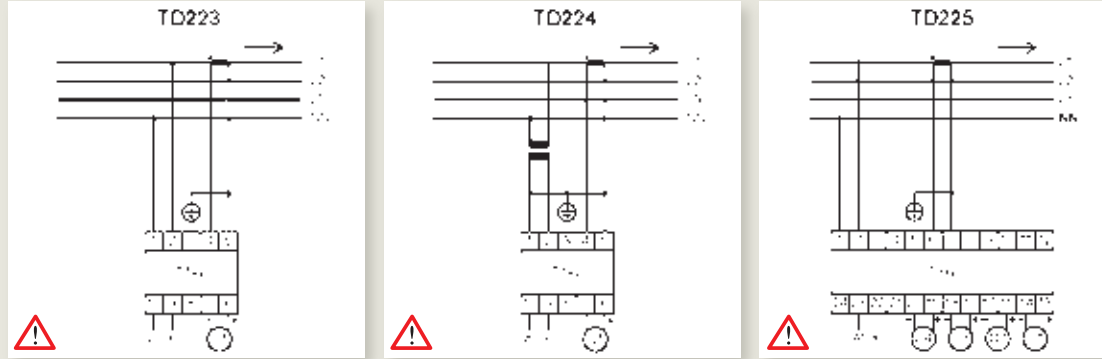

Phase rotation authorized

1
ENERGY
PERFORMANCE

2
NETWORK
QUALITY

3

MEASUREMENT AND
INSTRUMENTATION

Unbalanced 3-phase, 3-wire network

U12, U23, U31, F, Angle (U12/U23, U23/U31, U31/U12):

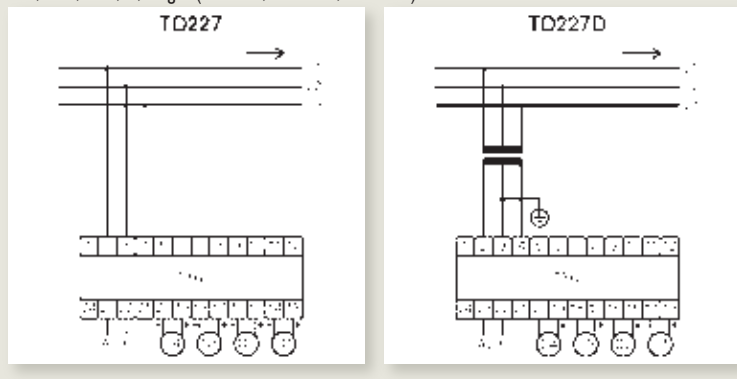

V1, V2, V3, U12, U23, U31, F,
Angle (V1/V2, V2/V3, V3/V1),
Angle (U12/U23, U23/U31, U31/U12):

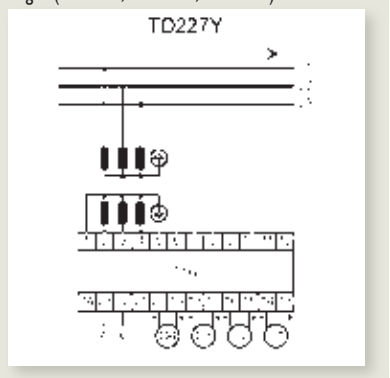



TRIAD 2 Range

Unbalanced 3-phase, 3-wire network (continued)

Programmable digital transducers
Measurement and instrumentation

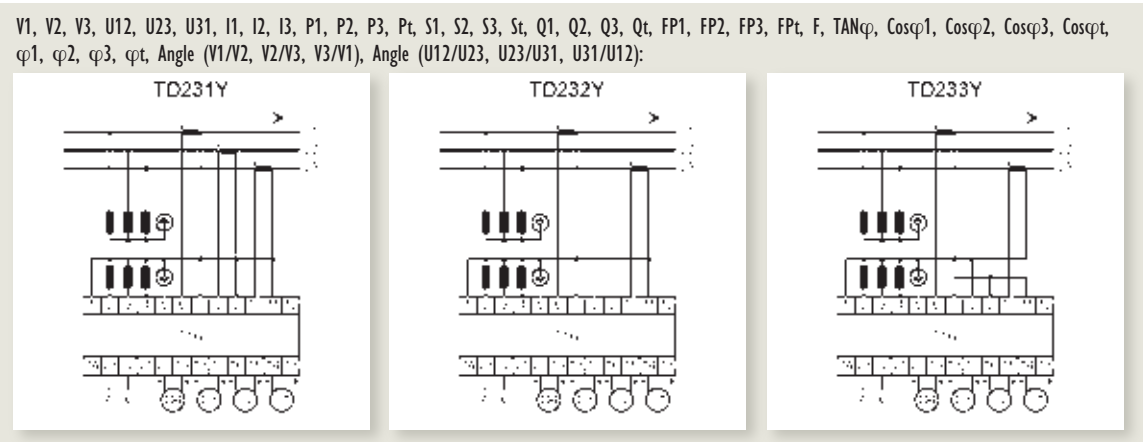
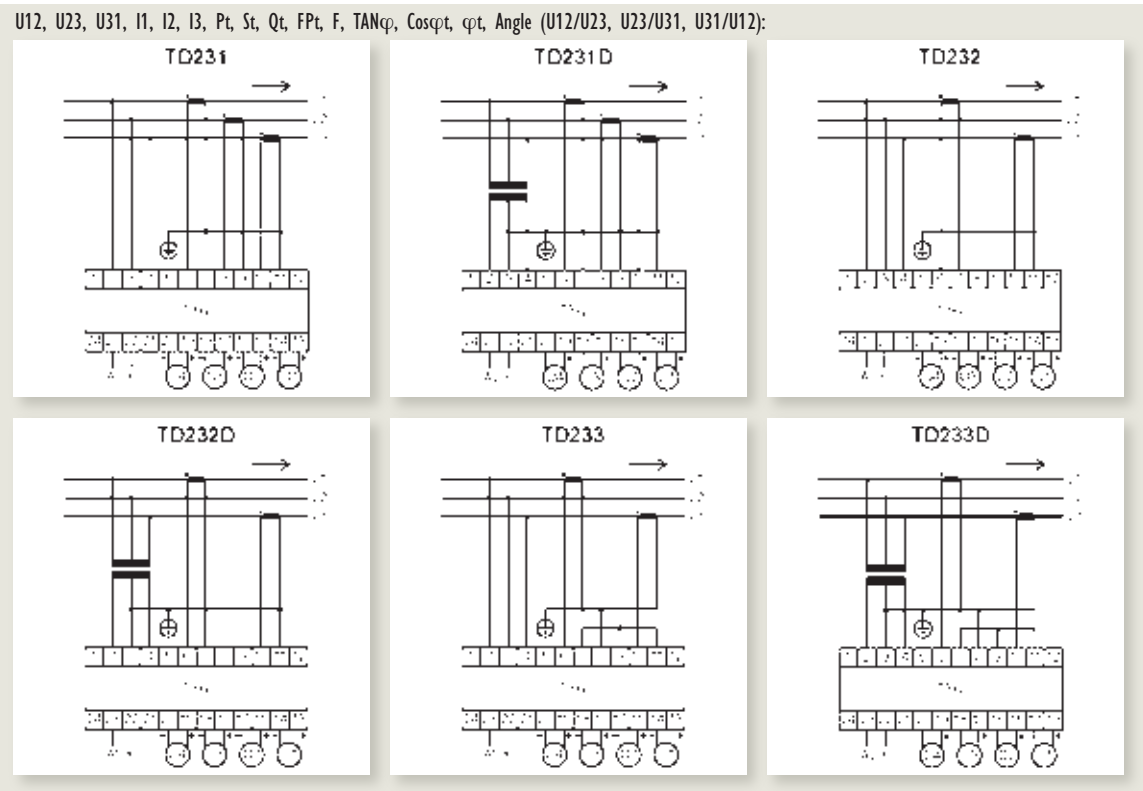
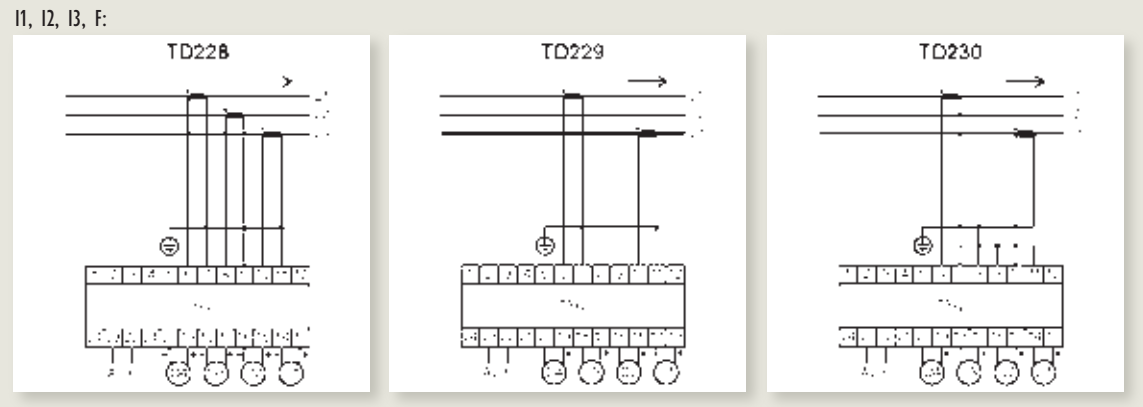

Unbalanced 3-phase, 4-wire network

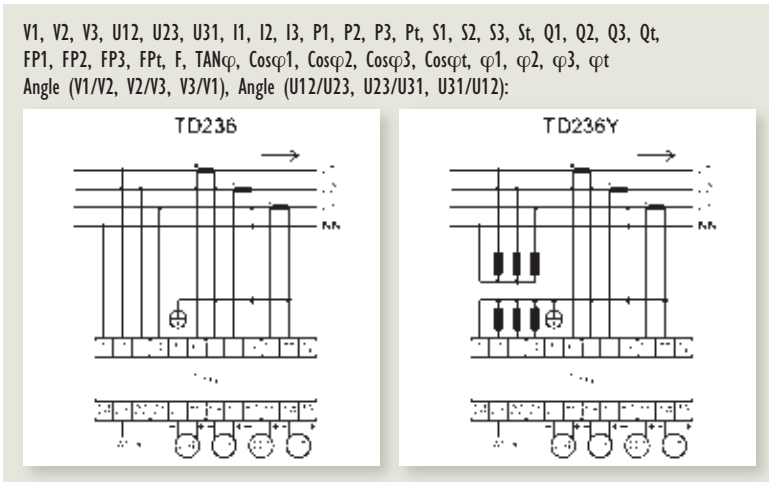
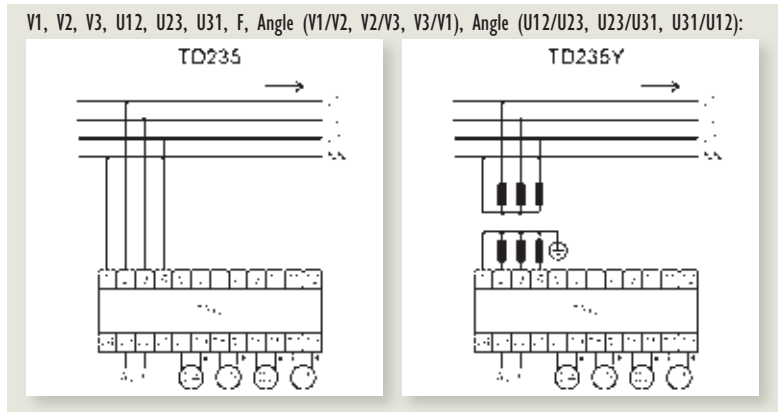
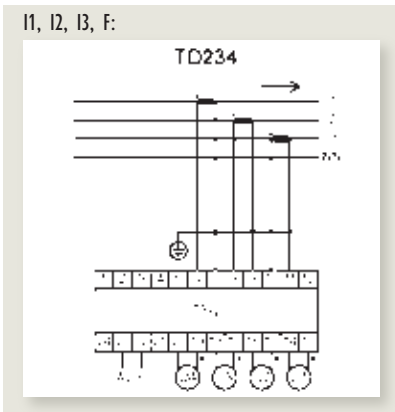

1

ENERGY
PERFORMANCE

2

NETWORK
QUALITY

3

MEASUREMENT AND
INSTRUMENTATION

► Dimensions (in mm)

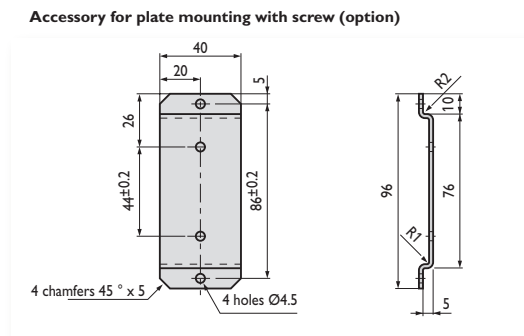
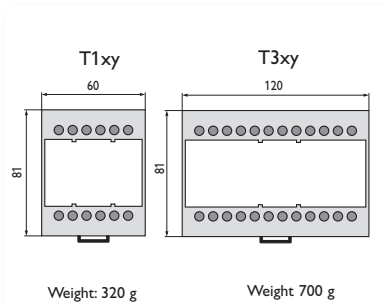
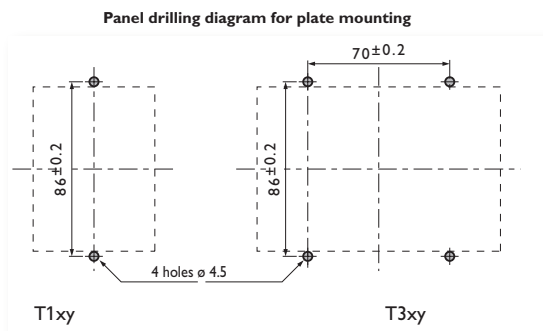
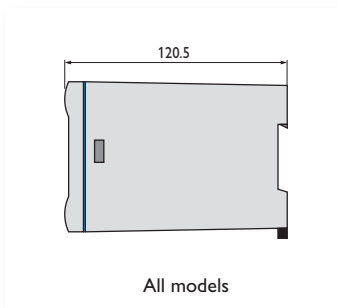



TRIAD 2 Range

TRIAD 2 programmable via TRIADJUST 2

Programmable digital transducers

TO ORDER

► T1 — SMALL MODEL (60 x 81 x 120.5 mm)

Link	Output	Supply	Without tropicalization	With tropicalization
			Number of input 1	Number of input 1
Optical	± 20 mA	80-265 V AC/DC	P01380001	P01380002
		19-58 V DC	P01380003	P01380004
	± 10 V	80-265 V AC/DC	P01380005	P01380006
		19-58 V DC	P01380007	P01380008

► T3 — LARGE MODEL (120 x 81 x 120.5 mm)

Link	Output	Supply	Without tropicalization				With tropicalization			
			Number of input(s)				Number of output(s)			
			1	2	3	4	1	2	3	4
Optical	± 20 mA	80-265 V AC/DC	P01380101	P01380103	P01380105	P01380107	P01380102	P01380104	P01380106	P01380108
		19-58 V DC	P01380109	P01380111	P01380113	P01380115	P01380110	P01380112	P01380114	P01380116
	± 10 V	80-265 V AC/DC	P01380117	P01380119	P01380121	P01380123	P01380118	P01380120	P01380122	P01380124
		19-58 V DC	P01380125	P01380127	P01380129	P01380131	P01380126	P01380128	P01380130	P01380132

► TRIAD 2 factory-programmable

1 Model

T1 : small model — 1 analogue output
T3 : large model — 1 to 4 analogue output(s)

2 Communication

0 : Without
1 : RS485
2 : Ethernet

3 Number of analogue outputs

0 : Without (Choice of a minimum communication)
1 : 1 output
2 : 2 outputs (T3 model only)
3 : 3 outputs (T3 model only)
4 : 4 outputs (T3 model only)

4 Frequency

0 : 50 Hz
1 : 60 Hz

5 Supply

0 : 80-265 V AC/DC
1 : 19-58 V DC

6 Tropicalization

0 : Without
1 : With

7 Analogue output calibres

0 : -20 mA to +20 mA
1 : -5 mA to +5 mA
2 : -1 mA to +1 mA
3 : -10 V to +10 V
4 : -1 V to +1 V

8 Network

0 : Single-phase
1 : Balanced 3-phase, 3 wires
2 : Balanced 3-phase, 4 wires
3 : Unbalanced 3-phase, 3 wires
4 : Unbalanced 3-phase, 4 wires

9 Connection configuration

Indicate the diagram number. E.g. TD204

10 Voltage input

Indicate direct voltage to be measured or the VT ratio

11 Current input

Indicate direct current to be measured or the CT ratio

12 Analogue output

Indicate for each output:

- a- Quantity to be measured
- b- Transfer curve
- c- Input signal: Min — Breaking point - Max
- d- Input unity
- e- Output signal: Min — Breaking point - Max

To simplify the procedure when ordering you can send us the form on page 207.

Factory-programmed TRIAD 2: order form

1 - Model / Hz

- T1 or T3
 50 Hz or 60 Hz

2 - Network

- Single-phase
 3-wire balanced three-phase
 4-wire balanced three-phase
 3-wire unbalanced three-phase
 4-wire unbalanced three-phase

3 - Options / Connection

- Ethernet or RS485
 Tropicalization
 Connection diagram: TD

4 - Power supply

- 80 to 265 Vac (50/60 Hz) / 80 to 265 Vdc or 19 to 58 Vdc

5 - Inputs

Current

With current transformer or Direct
 Primary Secondary
 / A A

Voltage

With voltage transformer or Direct
 Primary Secondary
 / V V
 Phase-phase Phase-neutral ($\sqrt{3}$)

Available quantities

V1 V2 V3 U12 U23 U31 I1 I2 I3 F P1 P2 P3 Pt Q1 Q2 Q3 Qt S1 S2 S3 St
 FP1 FP2 FP3 FPt TAN ϕ COS ϕ 1 COS ϕ 2 COS ϕ 3 COS ϕ t ϕ 1 ϕ 2 ϕ 3 ϕ t
 ϕ U12/23 ϕ U23/31 ϕ U31/12 ϕ V1/2 ϕ V2/3 ϕ V3/1

Output 1

Quantity and measurement range (x)

Indicate quantity to be measured
 Min breaking point Max Unit ⁽¹⁾

Transfer curve

- Linear
 2 slopes
 Quadratic

Output signal (y)

Min Breaking point Max mA V

Accuracy class

	50 Hz	60 Hz
<input type="checkbox"/> 0.1%:	1 s	0.8 s
<input type="checkbox"/> 0.15%:	0.5 s	0.4 s
<input type="checkbox"/> 0.2%:	0.2 s	0.16 s
<input type="checkbox"/> 0.5%:	100 ms	80 ms
<input type="checkbox"/> 1%:	50 ms	40 ms

Output 2

Quantity and measurement range (x)

Indicate quantity to be measured
 Min breaking point Max Unit ⁽¹⁾

Transfer curve

- Linear
 2 slopes
 Quadratic

Output signal (y)

Min Breaking point Max mA V

Accuracy class

	50 Hz	60 Hz
<input type="checkbox"/> 0.1%:	1 s	0.8 s
<input type="checkbox"/> 0.15%:	0.5 s	0.4 s
<input type="checkbox"/> 0.2%:	0.2 s	0.16 s
<input type="checkbox"/> 0.5%:	100 ms	80 ms
<input type="checkbox"/> 1%:	50 ms	40 ms

Output 3

Quantity and measurement range (x)

Indicate quantity to be measured
 Min breaking point Max Unit ⁽¹⁾

Transfer curve

- Linear
 2 slopes
 Quadratic

Output signal (y)

Min Breaking point Max mA V

Accuracy class

	50 Hz	60 Hz
<input type="checkbox"/> 0.1%:	1 s	0.8 s
<input type="checkbox"/> 0.15%:	0.5 s	0.4 s
<input type="checkbox"/> 0.2%:	0.2 s	0.16 s
<input type="checkbox"/> 0.5%:	100 ms	80 ms
<input type="checkbox"/> 1%:	50 ms	40 ms

Output 4

Quantity and measurement range (x)

Indicate quantity to be measured
 Min breaking point Max Unit ⁽¹⁾

Transfer curve

- Linear
 2 slopes
 Quadratic

Output signal (y)

Min Breaking point Max mA V

Accuracy class

	50 Hz	60 Hz
<input type="checkbox"/> 0.1%:	1 s	0.8 s
<input type="checkbox"/> 0.15%:	0.5 s	0.4 s
<input type="checkbox"/> 0.2%:	0.2 s	0.16 s
<input type="checkbox"/> 0.5%:	100 ms	80 ms
<input type="checkbox"/> 1%:	50 ms	40 ms

⁽¹⁾ Please indicate the unit of the measurement range, e.g. V, kW or MW



TRIADJUST 2 software

Designed for quick configuration and display of all the parameters of your TRIAD 2 transducers

Programmable digital transducers

Measurement and instrumentation

PRODUCT ADVANTAGES

- + **CONFIGURATION** via **OPTICAL HEAD, ETHERNET** or **RS485**
- + **ACCESS** to **ALL** the **TRIAD 2 PARAMETERS**
- + **DIAGNOSIS** of the **INSTALLATION**
- + **LABEL PRINTING** on **ALL TYPES OF LASER PRINTERS**



Configuration

- Inputs / Outputs
- Communication
- Connection diagram
- Response time

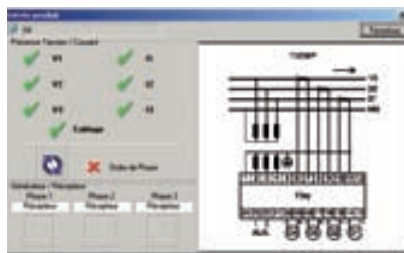

Diagnosis

- Voltage inputs
- Current inputs
- Cabling
- Phase order
- Analogue outputs
- Fresnel

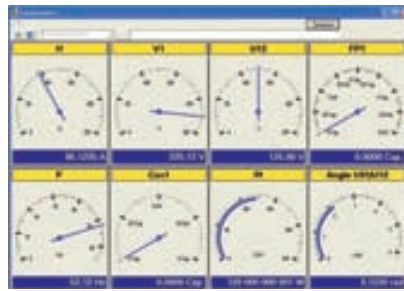

Display

- Instantaneous quantities (in digital or analogue form)

Recording

- In real time in exported file

► Description

The **TRIADJUST 2** software allows quick, unlimited programming of all your TRIAD 2's parameters.

Using a PC and the optical lead supplied in each kit, connect your product's auxiliary power supply to dialogue with total security. Depending on your TRIAD 2's configuration, remote communication is possible via RS485 or Ethernet.

In the Windows™ environment, initialize or simply modify the quantities measured, the measurement ranges and the analogue outputs on the transducers installed.

TRIADJUST 2 also offers other functions such as **DIAGNOSIS** of your network, instantaneous **DISPLAY** of the electrical quantities and **REAL-TIME RECORDING** of the measurements in an exported file.

You can also print labels indicating the configurations and connections of your products.

► Minimum configuration

Platform: PC

Operating system: Windows 2000 or XP

Processor: Pentium-compatible

RAM: 128 MB

Hard disk: 40 GB

Drive: CD-ROM

Communication port:

Local: USB 1.1 minimum

Remote: RS485 and/or Ethernet

KIT TRIADJUST 2



The **TRIADJUST 2 configuration kit** comprises:

- The TRIADJUST 2 software
- An optical / USB lead
- 30 sheets of blank labels
- A 230 x 185 x 45 mm carrying case

TRIADJUST 2 “PREMIER”

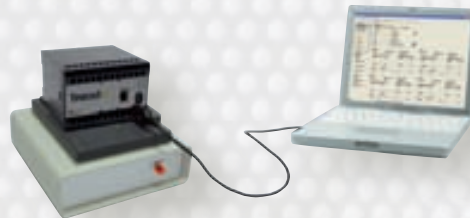

This module is a **complete tool** designed for distributors or any user needing to program a large number of transducers

The TRIADJUST 2 “PREMIER” configuration workstation comprises:

- The TRIADJUST 2 software
- An optical / USB lead
- A benchtop power-supply base
- 210 sheets of blank labels
- A 500 x 400 x 270 mm carrying case

Labels common to both kits

A sheet contains two labels, one for the configuration of the inputs/outputs and the other for the programmed connection diagram. The labels can be printed on all types of laser printers.

T314	
Inputs:	50-60 Hz
10 000 V/√3	100 V/√3
1 000 A	5A
AO 1: V1	0,20 200 ms 750 Ω
	0V...5 773,5V
	4 mA...20 mA
AO 2: I1	0,20 200 ms 750 Ω
	0A...1 000A
	4 mA...20 mA
AO 3: Pt	0,20 200 ms 750 Ω
	0W...17,32 MW
	4 mA...20 mA
AO 4: F1	0,20 200 ms 750 Ω
	45 Hz...55 Hz
	4 mA...20 mA
Made in France	
Reference client / Own reference customer	
<input style="width: 100%; height: 20px;" type="text"/>	

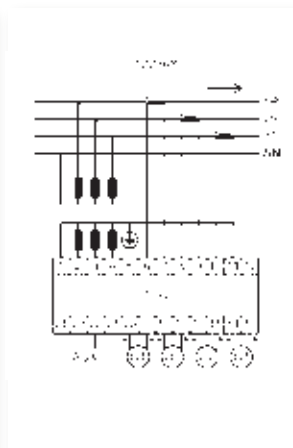

TO ORDER

Model	Reference
TRIADJUST 2 kit	P01380410
TRIADJUST 2 “PREMIER” workstation	P01380420
Accessories	
Set of 30 sheets of blank labels	P01380400
Optical/USB lead	P01330403

► Associated product

TRIAD 2 programmable
with TRIADJUST 2

► page 197



1
ENERGY
PERFORMANCE

2
NETWORK
QUALITY

3
MEASUREMENT AND
INSTRUMENTATION

2010

MICAR 2 Range

Multi-function digital transducers
2 or 4 analogue outputs / Class 0.2

Multi-function digital transducers
Measurement and instrumentation

PRODUCT ADVANTAGES

- + **CLASS 0.2**
Insulation 4 kV
- + Up to 4 **CONFIGURABLE ANALOGUE OUTPUTS**
- + Option of 2 or 4 **ON-OFF** outputs
- + **COMMUNICATION** and programming via optical head or remotely via Ethernet network or RS485 output
- + **ELECTRICAL NETWORK SUPERVISION** and display of the energy values, harmonics and THD using the **E.view+** software



Local communication via optical head



Remote communication via Ethernet network

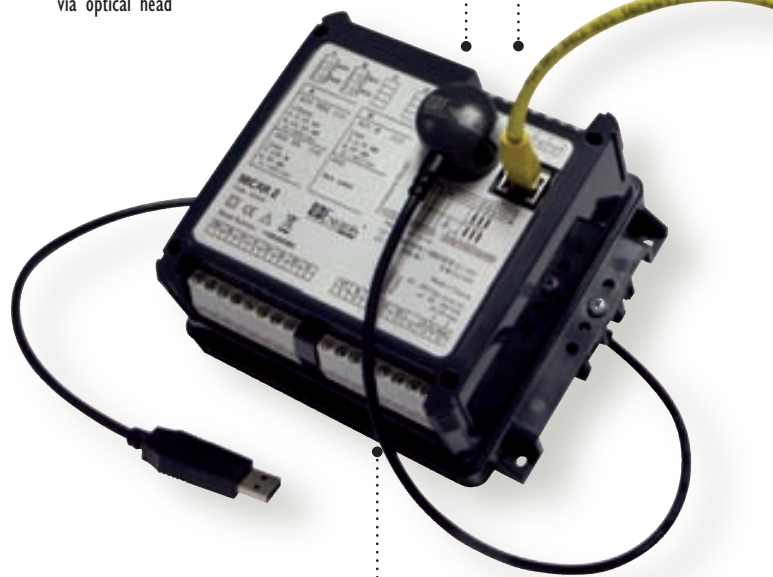

Simplified connection with screw-on terminal strip

► General specifications

Quantities measured:

Choice of 1, 2, 3 or 4 among 32 electrical quantities

Configuration: in factory or by user with the **E.view+** software

Accuracy: Class 0.2

Current inputs: 1 A and 5 A

Voltage inputs: 100 to 400 V (ph-ph) or $100 / \sqrt{3}$ to $400 / \sqrt{3}$ V (ph-N)

Transfer curves: linear, 2 slopes, quadratic

Output signal: configurable between - 20 mA and + 20 mA

Response time: 350 ms

Operating frequency: 50 or 60 Hz

Auxiliary source with wide dynamic range: 80 to 264V ac/dc or 19 to 57 Vdc

Compliance with CE directive

► Electrical specifications

Voltage inputs	
Rated value	100 V ≤ Un ≤ 400 V (ph-ph) 57.7 ≤ Vn ≤ 230 V (ph-N)
Frequency	50/60 Hz
Max. phase-to-phase voltage measured	650 kV (ph-ph)
Acceptable overvoltage	800 V for 24 hours. 552 V permanent
Consumption	< 0.2 VA
Input impedance	2 MΩ
Current inputs	
Rated value (In)	1 A and 5 A
Max. current measured on primary	25,000 A
Acceptable overload	6.5 A permanent, 250 A for 1 second, 5 times every 5 minutes
Consumption	< 0.15 VA
Auxiliary power supply	
High level (standard)	80 to 265 Vac / 80 to 264 Vdc (< 15 VA)
Low level (option)	19.2 to 57 Vdc
Pulse outputs or alarm relays	
Type	static relay
Operating voltage	24 to 110 Vdc ± 20% 24 to 115 Vac -10% +15%
Max. current	100 mA
Compliance with standard	IEC 62053-31
Analogue output	
Scale	Configurable between -20 mA and +20 mA
Acceptable load	500 Ω, 10 V/I output
Typical response time	350 ms
RS 485 output	
Connection	2 wires, half-duplex
Protocol	ModBus / JBus RTU mode
Speed (configurable)	2,400 – 4,800 - 9,600 – 19,200 – 38,400
Parity	even, odd or none
JBus addresses	1 to 247
Ethernet output	
Type	RJ45 – 8-pin
Protocol	ModBus/TCP
Speed (configurable)	Compatible with 10baseT

1

ENERGY
PERFORMANCE

2

NETWORK
QUALITY

3

MEASUREMENT AND
INSTRUMENTATION



MICAR 2 Range

Multi-function digital transducers

► Metrological specifications

Analogue outputs

Type	Conditions	Accuracy class
-20...+20 mA	Measurement of I, U, V, P, S, FP and F	Class 0.2 according to IEC 60688
	Measurement of Q	Class 0.5 according to IEC 60688

Digital communication output

Standard quantity	Conditions	Accuracy class
V	V between 10% and 120% of $V_n^{(1)}$	$\pm 0.2\%$ of V $\pm 0.02\%$ of V_n
U	U between 10% and 120% of $U_n^{(2)}$	$\pm 0.2\%$ of U $\pm 0.02\%$ of U_n
I	I between 5% and 130% of I_n	$\pm 0.2\%$ of I $\pm 0.02\%$ of I_n
F	F between 42.5 Hz and 69 Hz	± 0.1 Hz
P	FP between 0.5 inductive and 0.8 capacitive • U between 99% and 101% of $U_n^{(2)}$ • I between 5% and 130% of I_n	$\pm 0.2\%$ of P $\pm 0.02\%$ of P_n
Q	FP between 0.5 inductive and -0.5 capacitive • U between 99% and 101% of $U_n^{(2)}$ • I between 5% and 130% of I_n	$\pm 0.5\%$ of Q $\pm 0.05\%$ of Q_n
S	U between 99% and 101% of $U_n^{(2)}$ • I between 5% and 130% of I_n	$\pm 0.2\%$ of S $\pm 0.02\%$ of S_n
FP, Cos ϕ	FP between 0.5 inductive and 0.5 capacitive * U between 99% and 101% of $U_n^{(2)}$ * I between 5% and 130% of I_n	± 0.02 counts

⁽¹⁾ V_n from 57.7 V to 230 V ⁽²⁾ U_n from 100 V to 400 V

Special quantity	Accuracy class
Active energy	Class 0.5s according to IEC 62053-22
Reactive energy	Class 2 according to IEC 62053-23
Apparent energy	$\pm 0.5\%$
THD-I, THD-V and THD-U	± 0.5 counts
Harmonics order by order on U, V and I	± 0.5 counts

► Dimensions

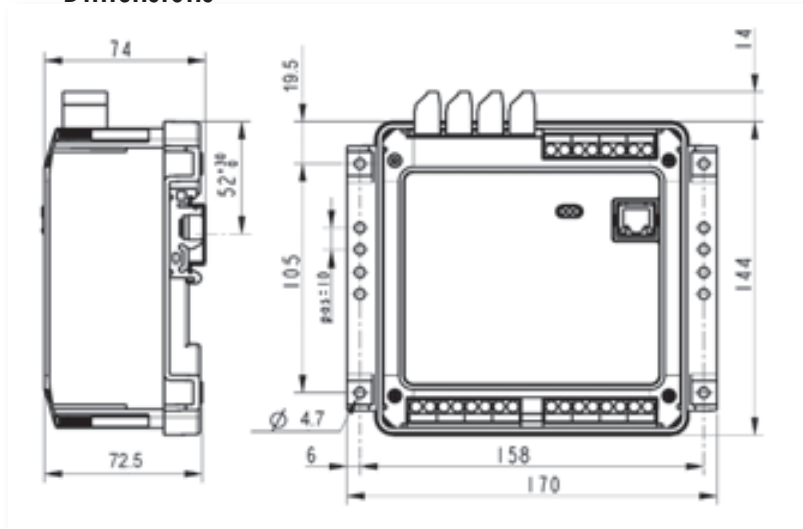

► Environmental specifications

Climate specifications	
Operating temperature	-10°C to +55°C
Operating humidity	95% at 40°C
Storage temperature	-25°C to +70°C
Safety specifications	
Degree of pollution	2
Behaviour in fire	UL94, severity V1
Installation category	3
Mechanical specifications	
Protection rating	IP51 on front panel and IP20 on rear panel
Mechanical shocks	IEC 61010-1
Vibrations	IEC 60068-2-6 (method A)
Free fall with packaging	NF H 0042-1
Electromagnetic compatibility	
Generic standard	IEC 61326-1

► Mounting accessories

Weight	700 g
Mounting	DIN 43700 rail or platen
Connection	Screw terminals for 6 mm ² rigid or flexible wires on current measurement inputs and 2.5 mm ² for the other accesses

► Functions

Measurement	On-off output				
	Analogue output	Alarm relay	Pulse output	Communication output	Display with E.view+
V1, V2, V3, Vearth	•	•		•	•
U12, U23, U31	•	•		•	•
I1, I2, I3, In	•	•		•	•
P1, P2, P3	•			•	•
Pt	•	•		•	•
Q1, Q2, Q3	•			•	•
Qt	•	•		•	•
S1, S2, S3	•			•	•
St	•	•		•	•
FP1, FP2, FP3	•			•	•
FPt	•	•		•	•
Cosφ1, Cosφ2, Cosφ3,	•			•	•
Cosφt	•	•		•	•
Frequency	•	•		•	•
Crest factor V1, V2, V3				•	•
Crest factor I1, I2, I3				•	•
Unbalance U				•	•
Harmonics: V1, V2, V3, U12, U23, U31, I1, I2, I3				•	•
THD: V1, V2, U12, U23, U31, I1, I3				•	•
Active energy: receiver, generator			•	•	•
Reactive energy: Qcad1, Qcad2, Qcad3, Qcad4			•	•	•
Apparent energy: receiver, generator			•	•	•

1

ENERGY
PERFORMANCE

2

NETWORK
QUALITY

3

MEASUREMENT AND
INSTRUMENTATION



MICAR 2 Range

Multi-function digital transducers
Measurement and instrumentation

► Electrical connections

Configurations for single-phase networks

I1, V1, P1, S1, Q1, FP1, Cosp1, F:

TD301 configuration

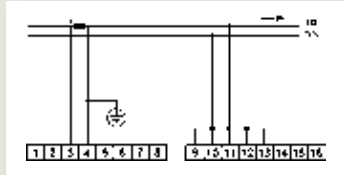

TD302 configuration

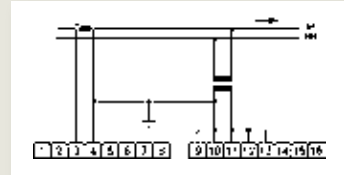

Balanced 3-phase network with 4 wires

I1, I2, I3, V1, V2, V3, P1, P2, P3, Pt, S1, S2, S3, St, Q1, Q2, Q3, Qt, FP1, Fp2, Fp3, FPt, Cosp1, Cosp2, Cosp3, Cospt, F:

TD303 configuration

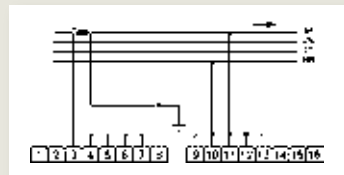

TD304 configuration

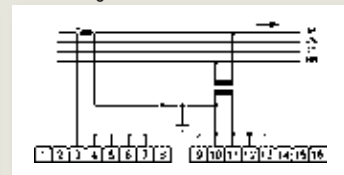

Unbalanced 3-phase network with 3 wires

I1, I2, I3, U12, U23, U31, P1, P2, P3, Pt, S1, S2, S3, St, Q1, Q2, Q3, Qt, FP1, FP2, FP3, FPt, Cosp1, Cosp2, Cosp3, Cospt, F:

TD320 configuration

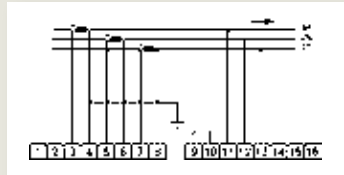

TD320D configuration

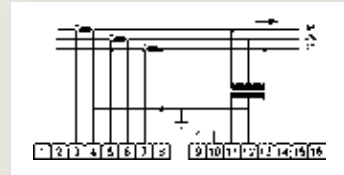

TD320Y configuration

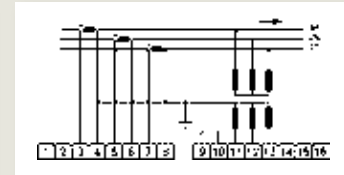

TD324 configuration

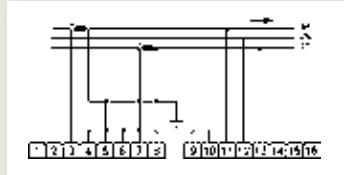

TD324D configuration

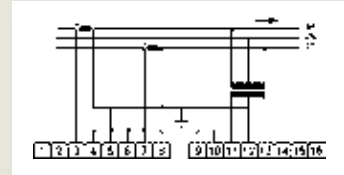

I1, I2, I3:

TD322 configuration

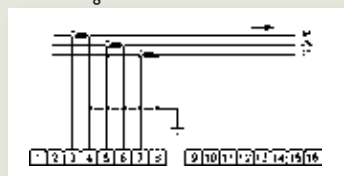

TD323 configuration

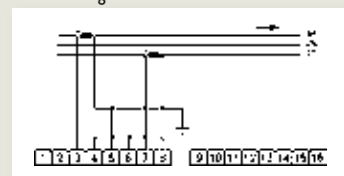

U12, U23, U31:

TD321 configuration

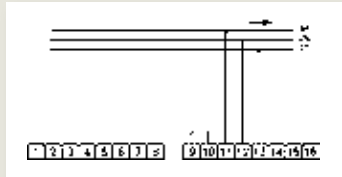

TD321D configuration

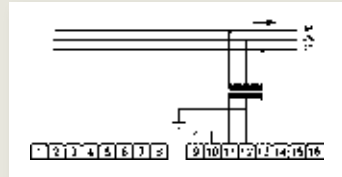

Unbalanced 3-phase network with 4 wires

I1, I2, I3:

TD314 configuration

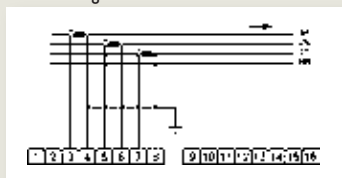

V1, V2, V3, U12, U23, U31, F:

TD317 configuration

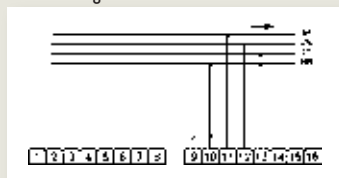

TD317Y configuration

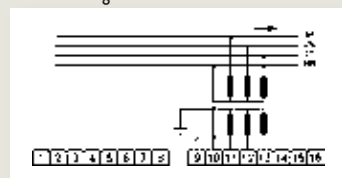

I1, I2, I3, Ineutral:

TD334 configuration

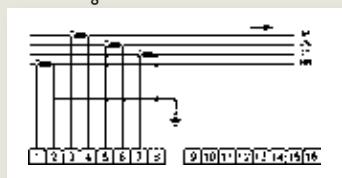

V1, V2, V3, Vearth, U12, U23, U31, F:

TD337 configuration

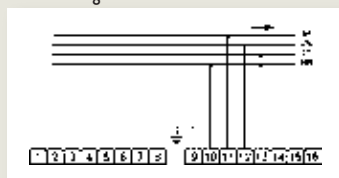

TD337Y configuration

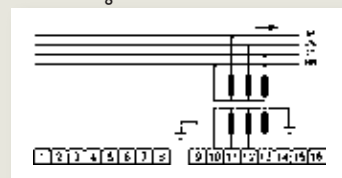

I1, I2, I3, V1, V2, V3, U12, U23, U31, P1, P2, P3, Pt, S1, S2, S3, St, Q1, Q2, Q3, Qt, FP1, FP2, FP3, FPt, Cosφ1, Cosφ2, Cosφ3, Cosφt, F:

TD315 configuration

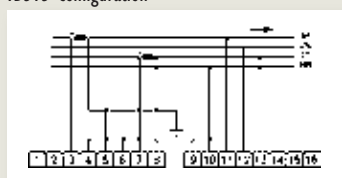

TD315Y configuration

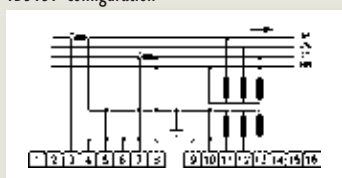

TD318 configuration

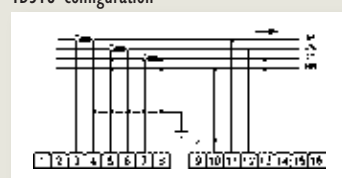

TD318Y configuration

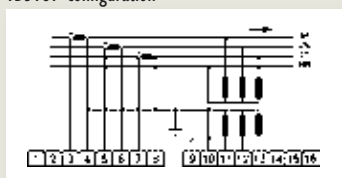

I1, I2, I3, Ineutral, V1, V2, V3, Vterre, U12, U23, U31, P1, P2, P3, Pt, S1, S2, S3, St, Q1, Q2, Q3, Qt, FP1, FP2, FP3, FPt, Cosφ1, Cosφ2, Cosφ3, Cosφt, F:

TD338 configuration

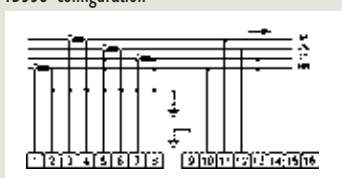

TD338Y configuration

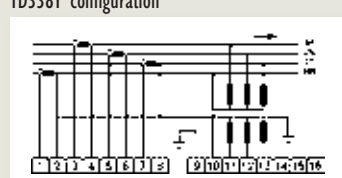



MICAR 2 Range

The **E.view+** software can be used with the **MICAR 2** range for configuration, installation diagnosis and display of the electrical quantities.

Multi-function digital transducers

Measurement and instrumentation

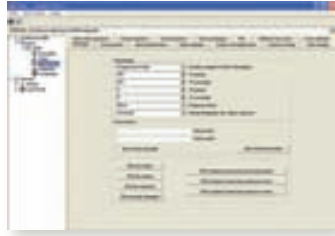

Configuration

- Configure your MICAR 2 transducers remotely via the RS485, Ethernet or local area network using the optical head
- Program the products' communication parameters and the configuration parameters (CT ratio, VT, alarm thresholds, etc.)



Diagnosis

- View the phase order and the Fresnel diagram
- Control the analogue and on-off outputs remotely

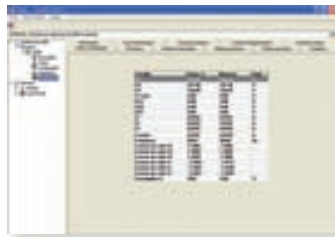

Display

- View the basic electrical quantities in real time
- View the harmonics in histogram format

TO ORDER

Product	Code
MICAR with tailored configuration	Complete the order form
Programmable MICAR 2, power supply 80-264 V AC/DC, RS485, 2 analogue outputs (without programming kit)	P01 330 840
Programmable MICAR 2, power supply 80-264 V AC/DC, RS485, 4 analogue outputs (without programming kit)	P01 330 841
Programming kit	Code
MICAR 2 – RS485 kit containing 1 optical head + 1 set of 50 labels + RS485 output + 1 E.view+ CD	P01 330 842
MICAR 2 – Ethernet kit containing 1 optical head + 1 set of 50 labels + Ethernet output + 1 E.view+ CD	P01 330 843
Accessories*	Code
Set of 50 labels for RS485 output	P01 330 844
Set of 50 labels for Ethernet output	P01 330 845

* labels printable only on laser printers

Associated products

Analogue panel meters

▶ page 154



Digital panel meters

▶ page 130



CT Current transformers

▶ page 90



E.view+ software

▶ page 63



Factory-programmed MICAR 2: order form

1 – Network

- Single-phase
- Balanced 3-phase, 3 wires
- Balanced 3-phase, 4 wires
- Unbalanced 3-phase, 3 wires
- Unbalanced 3-phase, 4 wires

2 – Frequency

- 50 Hz
- or
- 60 Hz

3 – Connection options

- Ethernet (no RS485)
- Tropicalization
- 2 on-off outputs or 4 on-off outputs

Connection configuration: TD

4 - Power supply

- 80 to 265 Vac (50/60 Hz) / 80 to 264 Vdc or 19 to 57 Vdc

5 – Inputs

Current

With current transformer or Direct
 Primary Secondary A / A A

Voltage

With voltage transformer or Direct
 Primary Secondary V / V V

Phase-phase Phase-neutral

Quantities available

V1 V2 V3 Yearth U12 U23 U31 I1 I2 I3 Ineutral P1 P2 P3 Pt Q1 Q2 Q3 Qt S1 S2 S3 St
 FP1 FP2 FP3 FPt COSφ1 COSφ2 COSφ3 COSφt F

Output 1

Quantity and measurement range (x)

Indicate the quantity to be measured

Min Breaking point Max Unit ⁽¹⁾

Transfer curve

- Linear
- 2 slopes
- Quadratic

Output signal (y)

Min Breaking point Max mA

Output 2

Quantity and measurement range (x)

Indicate the quantity to be measured

Min Breaking point Max Unit ⁽¹⁾

Transfer curve

- Linear
- 2 slopes
- Quadratic

Output signal (y)

Min Breaking point Max mA

Output 3

Quantity and measurement range (x)

Indicate the quantity to be measured

Min Breaking point Max Unit ⁽¹⁾

Transfer curve

- Linear
- 2 slopes
- Quadratic

Output signal (y)

Min Breaking point Max mA

Output 4

Quantity and measurement range (x)

Indicate the quantity to be measured

Min Breaking point Max Unit ⁽¹⁾

Transfer curve

- Linear
- 2 slopes
- Quadratic

Output signal (y)

Min Breaking point Max mA

⁽¹⁾Please indicate the unit for the measurement range, e.g. V, kW or MW.

2010

TSP 2 Range

Self-powered version for applications requiring the conversion of a single AC current or voltage quantity. 1 analogue output class 0.2 for all type of electrical network

Measurement and instrumentation Analogue transducers

PRODUCT ADVANTAGES

- + SELF-POWERED
- + CLASS 0.2
- + WIDE CHOICE OF INPUTS CALIBRED
- + RESPONSE TIME of 100 ms for TSPI and 200 ms for TSPU



Accessibility and safety:
large-dimension terminals
Insulated circuits

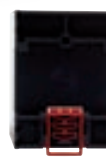

Ergonomic: easy mounting on DIN
rail or switchboard

► Main specifications

TSPU

Quantity measured: Vac, Uac

Accuracy: Class 0.2

Inputs: AC voltage: 57.5 V to 400 V (fixed calibres)

Analogue output calibres: 0-10 mA, 0-20 mA, 0-5 V, 0-10 V

Operating frequency: 45 to 65 Hz

TSPI

Quantity measured: Iac

Accuracy: Class 0.2

Inputs: AC current: 1 A or 5 A (fixed calibres)

Analogue output calibres: 0-10 mA, 0-20 mA

Operating frequency: 45 to 65 Hz

► Functions

Network	Function	TSPI model	TSPU model
Single phase	V		•
	I	•	
Balanced 3-phase 3 wires	U12 or U23 or U31		•
	I1 or I2 or I3	•	
Balanced 3-phase 4 wires	V1 or V2 or V3 or U12 or U23 or U31		•
	I1 or I2 or I3	•	
Unbalanced 3-phase 3 wires	U12 or U23 or U31		•
	I1 or I2 or I3	•	
Unbalanced 3-phase 4 wires	V1 or V2 or V3 or U12 or U23 or U31		•
	I1 or I2 or I3	•	

1
ENERGY
PERFORMANCE

► Electrical connections

TSPU

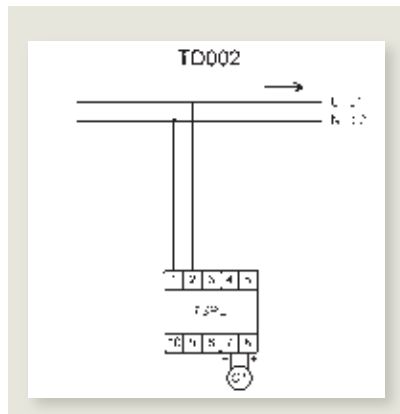

TSPI

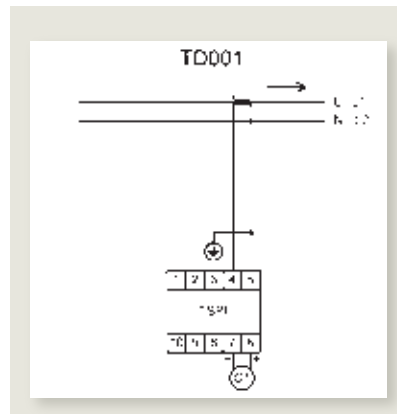

2
NETWORK
QUALITY

3
MEASUREMENT AND
INSTRUMENTATION

The terminal 1 can be connected either on the neutral or on one phase of the electrical network



TSP 2 Range

Analogue transducers

Measurement and instrumentation

► Dimensions (in mm)

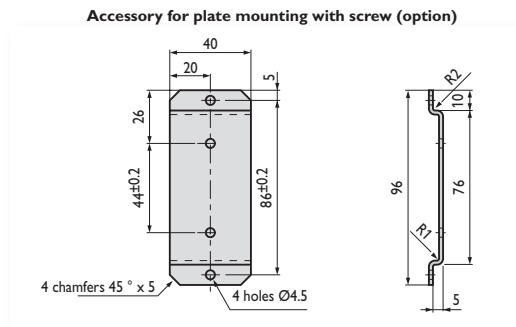
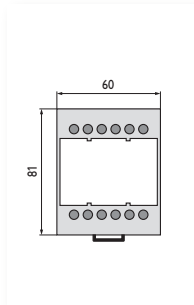
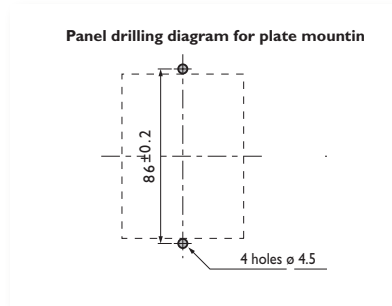
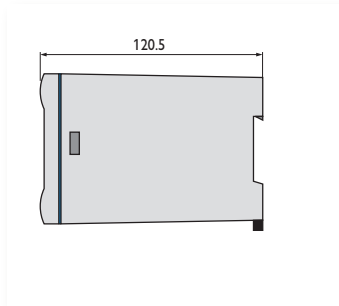

► Environment and standards

Standard of reference: CEI 60688	
EMC IMMUNITY	
Shock voltage	IEC 61000-4-5
Oscillating wave	IEC 61000-4-12
Fast electrical transients in bursts	IEC 61000-4-4
Electrostatic discharge	IEC 61000-4-2
EM radiated field	IEC 61000-4-3

Climatic specifications (CEI 60068 2-1 / 2-2 / 2-30)	
Operating temperature	-10°C to +55°C
Storage temperature	-40°C to +70°C
Relative humidity	≤ 95% at 55°C

Safety specifications (IEC 61010-1)	
Installation category	3
Pollution level	2
Fire resistance	UL94, severity V0

Mechanical specifications	
Protection rating	IP 20
Mechanical shocks	IEC 60068-2-27
Vibrations	IEC 60068-2-6
Drop test with packaging	NF H0042-1

► Mounting accessories

Model	Reference
Plate mounting	ACCT 1007

► Casing

Weight	320g
Mounting	DIN rail 43700 or plate mounting
Connection	Terminals with mobile stirrup clamp with screw for 4 single-wire 6 mm ² conductors or 2 multi-wire 4 mm ² conductors

► Electrical and metrological specifications

Model	TSPI I (rms)	TSPU U or V (rms)
Current or voltage input		
Rated value	$I_n = 1$ or 5 A	$V_n = 100/\sqrt{3}, 110/\sqrt{3}, 120/\sqrt{3}$ V $U_n = 100, 110, 120, 230, 400$ V
Frequency F_n	46...65 Hz	46...65 Hz
Measurement range $0...X_{max}$	0...100% of I_n	0...100% of U_n/V_n
Consumption	2 VA	2 VA
Maximum overloads	2 I_n permanent 20 I_n / 1 s 40 I_n / 0.5 s	1.5 U_n permanent 2 U_n / 1 s 4 U_n / 0.5 s
Analogue output		
Transfer curve	linear	
$0...Y_{max}$	0...10 mA 0...20 mA	0...10 mA 0...20 mA 0...5 V 0...10 V
Accuracy	Class 0.2: 10...100% of I_n	Class 0.2: 50...100% of V_n / U_n
Response time	< 100 ms	< 200 ms
Operating resistance	15 V /Is	≥ 1 k Ω
Peak-peak residual wave	40 μ A	20 mV
Auxiliary power supply		
Self-powered	•	•

 Parameters to be indicated when ordering

TO ORDER

Input	Output	Tropicalization	
		with	without
0...1 A	0...10 mA	P01 3751 01	P01 3751 05
	0...20 mA	P01 3751 02	P01 3751 06
0...5 A	0...10 mA	P01 3751 03	P01 3751 07
	0...20 mA	P01 3751 04	P01 3751 08

Input	Output	Tropicalization	
		with	without
0...57.7 V	0...10 mA	P01 3752 01	P01 3752 33
	0...20 mA	P01 3752 02	P01 3752 34
	0...5 V	P01 3752 03	P01 3752 35
	0...10 V	P01 3752 04	P01 3752 36
0...63.5 V	0...10 mA	P01 3752 05	P01 3752 37
	0...20 mA	P01 3752 06	P01 3752 38
	0...5 V	P01 3752 07	P01 3752 39
	0...10 V	P01 3752 08	P01 3752 40
0...69.3 V	0...10 mA	P01 3752 09	P01 3752 41
	0...20 mA	P01 3752 10	P01 3752 42
	0...5 V	P01 3752 11	P01 3752 43
	0...10 V	P01 3752 12	P01 3752 44
0...76.2 V	0...10 mA	P01 3752 65	P01 3752 66
	0...10 mA	P01 3752 13	P01 3752 45
0...100 V	0...20 mA	P01 3752 14	P01 3752 46
	0...5 V	P01 3752 15	P01 3752 47
	0...10 V	P01 3752 16	P01 3752 48

Input	Output	Tropicalization	
		with	without
0...110 V	0...10 mA	P01 3752 17	P01 3752 49
	0...20 mA	P01 3752 18	P01 3752 50
	0...5 V	P01 3752 19	P01 3752 51
	0...10 V	P01 3752 20	P01 3752 52
0...120 V	0...10 mA	P01 3752 21	P01 3752 53
	0...20 mA	P01 3752 22	P01 3752 54
	0...5 V	P01 3752 23	P01 3752 55
	0...10 V	P01 3752 24	P01 3752 56
0...230 V	0...10 mA	P01 3752 25	P01 3752 57
	0...20 mA	P01 3752 26	P01 3752 58
	0...5 V	P01 3752 27	P01 3752 59
	0...10 V	P01 3752 28	P01 3752 60
0...400 V	0...10 mA	P01 3752 29	P01 3752 61
	0...20 mA	P01 3752 30	P01 3752 62
	0...5 V	P01 3752 31	P01 3752 63
	0...10 V	P01 3752 32	P01 3752 64

1

ENERGY
PERFORMANCE

2

NETWORK
QUALITY

3

MEASUREMENT AND
INSTRUMENTATION

2010

T82 Range

Analogue transducers for AC/DC electrical quantities or physical quantities, class 0.5

Measurement and instrumentation

Analogue transducers

PRODUCT ADVANTAGES

- + AVAILABLE IN 3 VERSIONS:**
plate mounting, plug-in or rack
- + CONFIGURABLE ON REQUEST:** input quantities, transfer curve, output signal, etc.
- + WIDE RANGE OF MEASURABLE QUANTITIES:**
AC/DC electrical quantities and physical quantities



Plug-in version with special socket for plate mounting or DIN rail mounting



Rack version for 19" - 3U: model supplied rack-mounted or separately, comes with connections

► Description

The **T82** range of transducers measures AC/DC electrical quantities and physical quantities and converts them into a standard low-level direct signal (current or voltage) (for example: 4...20 mA).

They are normally used in conjunction with analogue or digital measuring instruments (panel meters, recorders, etc.), supervision equipment (PLCs, SCADA and building management automation systems) and are also incorporated in control and measurement loops.

► Electrical specifications

■ Inputs

- Input U: 1.5 U_n permanent
2 U_n during 10 s
4 U_n during 0.5 s
- Input I: 2 I_n permanent
10 I_n during 5 s
30 I_n during 3 s
50 I_n during 1 s
- Frequency: 50 Hz (45...55 Hz)
60 Hz (55...65 Hz)
400 Hz (350...450 Hz)

■ Analogue output

- Accuracy: class 0.5 as per IEC 60688
- Response time: 0.3 s at 95% of output current
- Permitted overloads:
Current output: 1.1 I_s
Voltage output: 1.1 U_s

- Operating resistance:
Current output: 20V/ I_s
Voltage output: 1 k Ω
- Influence of operating resistance:
 $\pm 0.1\%$ from 0 to Max operating resistance
- Repeat accuracy: 0.1%
- Peak-to-peak ripple: 0.4%

■ Auxiliary supply

- Operating range:
 $\pm 20\%$ from 100/ $\sqrt{3}$ to 127 Vac
 $\pm 10\%$ from 220 to 440 Vac
 $\pm 20\%$ from 24 to 220 Vdc
- Consumption:
 ≤ 3 VA from 100/ $\sqrt{3}$ to 440 Vac
 ≤ 3 W from 24 to 220 Vdc

► Reference standards

■ IEC 60688

(Electrical measurement transducers)

■ Electromagnetic compatibility EMC(89/336/EEC)

- Shock voltage as per IEC 61000-4-5:
5 kV in common mode (wave 1.2 / 50 μ s)
- Attenuated oscillation wave as per IEC 61000-4-12:
1 kV in differential mode
2.5 kV in common mode

■ Low voltage directive: 73/23/EEC

■ Insulation and dielectric strength: IEC 61010-1

- Between the input circuits, auxiliary supply and output circuits: 2 kV - 50 Hz - 1 min

- Between auxiliary supply and other terminals:
2 kV - 50 Hz - 1 min
- Between circuits and earth: 4 kV - 50 Hz - 1 min

■ Mechanical shocks: IEC 60068-2-27

- Acceleration: 50 g
- Number of shocks: 3 x 6

■ Vibrations: IEC 60068-2-6

- Frequency: 10-55 Hz
- Amplitude: 1.5 mm
- Number of cycles: 12

■ Operating environment:

- Operating temperature: -10°C to +60°C

► Casing

Screw connection terminals 2 x 2.5 mm²
or 1 x 6 mm²

■ IP20 protection rating as per IEC 60529

■ Weight

0.60 to 0.85 kg (Socket: 0.25 kg)
Mesurack 5E socket: 0.35 to 0.5 kg
Mesurack 10E socket: 0.6 to 0.7 kg

1

ENERGY
PERFORMANCE

2

NETWORK
QUALITY

3

MEASUREMENT AND
INSTRUMENTATION



T82 Range

Analogue transducers
Measurement and instrumentation

► Dimensions (in mm)

T82 plate-mounting module

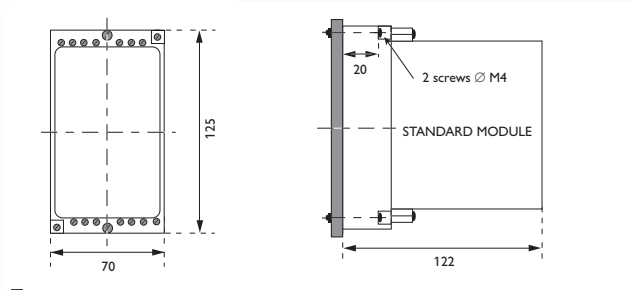

T82 plug-in module

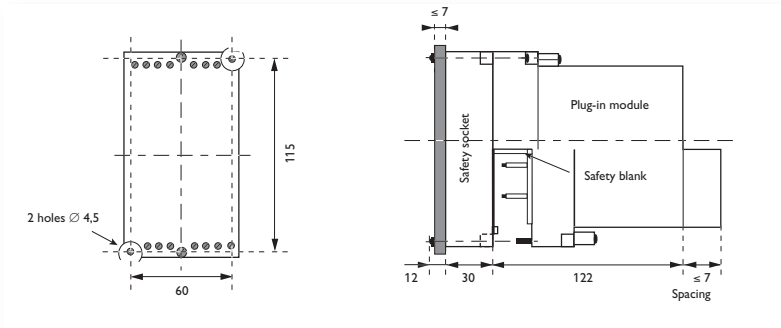

T82 rack

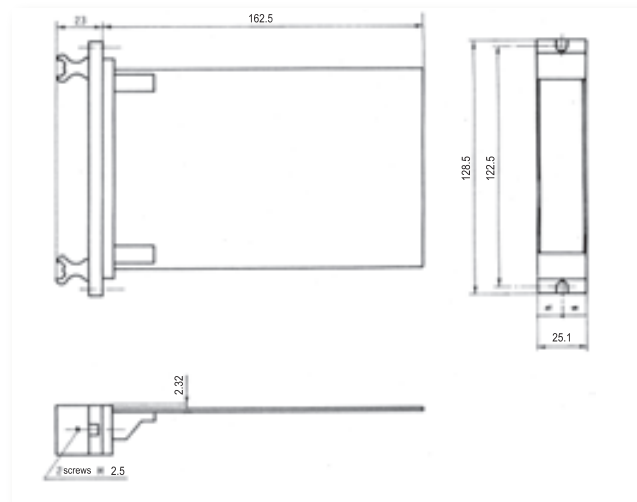

19" - 3U rack

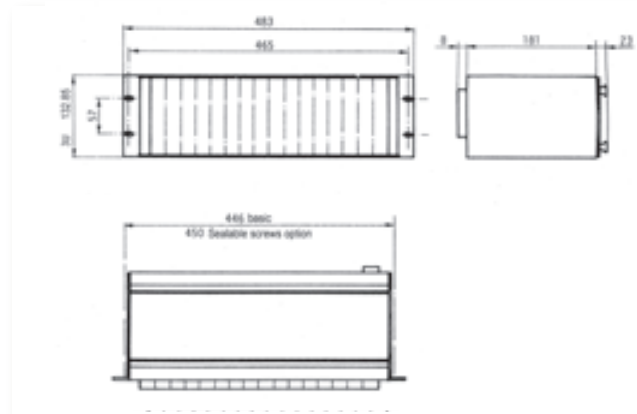

► Mounting accessories

■ Connection socket for plug-in module



Model	Connection socket	
	Type	Reference
UAN 1210B	2	EMBB 4002
UAR 1210B	5	EMBB 4005
UAX 1210B	5	EMBB 4005
UAZ 1220B	2	EMBB 4006
UAZ 1210B	6	EMBB 4002
UER 1210B	5	EMBB 4005
UQR 1210B	5	EMBB 4005
UQX 1210B	5	EMBB 4005
UEX 1210B	5	EMBB 4005
IAN 1210B	1	EMBB 4001
IAR 1210B	4	EMBB 4004
IER 1210B	4	EMBB 4004
IQR 1210B	4	EMBB 4004
IAR 1211B	4	EMBB 4004

Model	Connection socket	
	Type	Reference
FAR 1210B	5	EMBB 4005
FCR 1210B	5	EMBB 4004
JAR 1211B	4	EMBB 4004
JAR 1221B	5	EMBB 4005
UAR 1221B	7	EMBB 4007
PAR 1211B	4	EMBB 4004
PAR 1231B	4	EMBB 4004
PAR 1232B	3	EMBB 4003
PAR 1233B	9	EMBB 4009
PAR 1234B	10	EMBB 4010
PAR 1235B	4	EMBB 4004
QAR 1211B	4	EMBB 4004
QAR 1232B	3	EMBB 4003
QAR 1233B	9	EMBB 4009
QAR 1234B	10	EMBB 4010

Model	Connection socket	
	Type	Reference
UCR 1220B	5	EMBB 4005
UCR 1420B	5	EMBB 4005
UCR 1230B	5	EMBB 4005
UCR 1216B	7	EMBB 4007
ICR 1220B	5	EMBB 4005
ICR 1420B	5	EMBB 4005
ICR 1230B	5	EMBB 4005
ICR 1216B	7	EMBB 4007
TCL 1220B	6	EMBB 4006
RCL 1220B	6	EMBB 4006
RCR 1211B	6	EMBB 4006

■ Mounting on DIN rail for plate-mounting or plug-in module



Model	Reference
Mounting on symmetrical DIN rail	PDIN SYME
Mounting on asymmetrical DIN rail	PDIN ASYM

► Electrical connections

See document MS 0/1-7343.

1
ENERGY
PERFORMANCE

2
NETWORK
QUALITY

3
MEASUREMENT AND
INSTRUMENTATION



T82 Range

Measurement and instrumentation Analogue transducers



AC RMS voltage



Model	UAN 1210 B	UAR 1210 B	UAX 1210 B	UAZ 1210 B	UAZ 1220 B						
Transfer curve											
Linear	•	•									
Expanded (1 slope)			•	•							
Expanded (2 slopes)					•						
Module											
Plate mounting	0.6 kg	0.7 kg	0.7 kg	0.7 kg	0.7 kg						
Plug-in	0.6 kg	0.7 kg	0.7 kg	0.7 kg	0.7 kg						
Rack	10 E / 0.5 kg	5 E / 0.3 kg	5 E / 0.3 kg								
Measurement input											
Voltage U_n	Direct or on VT: 100/ $\sqrt{3}$ 110/ $\sqrt{3}$ 115/ $\sqrt{3}$ 132/ $\sqrt{3}$ 90 100 110 115 127 132 138 180 220 250 300 360 380 440 Vac										
Frequency	50, 60 or 400 Hz										
Measurement range 0... X_{max}	0...1.25 U_n	0...1.25 U_n	0.8 U_n ...1.2 U_n	0.8 U_n ...1.2 U_n	0.8 U_n ...1.2 U_n						
Consumption	< 2 VA	1 k Ω / V	1 k Ω / V	< 2 VA	< 2 VA						
Analogue output											
Current	0... Y_{max}	0...1 mA	0...2.5 mA	0...5 mA	0...10 mA	0...20 mA	0...0.1...1 mA	0...0.25...2.5 mA	0...0.5...5 mA	0...1...10 mA	0...2...20 mA
	Y_{min} ... Y_{max}		1...5mA	2...10mA	4...20mA						
Voltage	0... Y_{max}	0...1V	0...5V	0...10V							
	Y_{min} ... Y_{max}		1...5V	2...10V							
Accuracy	0.5 % de 0.5 U_n ... U_n					0.5%					
Auxiliary supply											
Alternating current		100/ $\sqrt{3}$ 110/ $\sqrt{3}$ 115/ $\sqrt{3}$ 100 110 115 127 Va	220 230 240 380 400 440 Vac								idem UAR 1210 B
Direct current		24 48 110 125 220 Vdc									idem UAR 1210 B
Self-powered	•										•
Protection rating											
Plate mounting						IP 20					
Plug-in						IP 20					
Rack						IP 20					

Parameters to be specified when ordering

TO ORDER

Model	Module	Measurement range	Frequency	Analogue output	Auxiliary supply	Protection	Tropicalization	Reference
UAN 1210 B	Fixed	0...100 V	50 Hz	0...20 mA	self-powered	IP 20	without	UANA 3002
		0...380 V	50 Hz	0...20 mA	self-powered	IP 20	without	UANA 3001
UAR 1210 B	Fixed	0...100 V	50 Hz	4...20 mA	220 Vac	IP 20	without	UARD 3002
		0...100/ $\sqrt{3}$ V	50 Hz	4...20 mA	220 Vac	IP 20	without	UARD 3004
		0...380 V	50 Hz	4...20 mA	220 Vac	IP 20	without	UARD 3003

Customized products

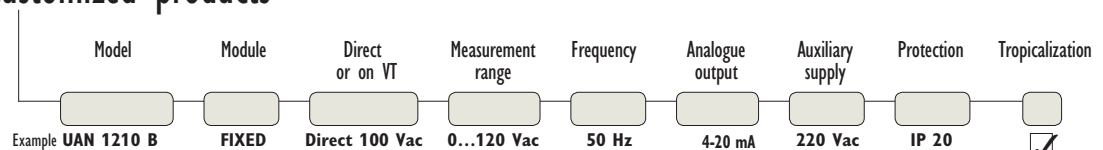

AC true RMS voltage



1
ENERGY
PERFORMANCE

2
NETWORK
QUALITY

3
MEASUREMENT AND
INSTRUMENTATION

Model	UER 1210 B	UQR 1210B	UQX 1210B	UEX 1210B
Transfer curve				
Linear	•			
Expanded				•
Quadratic		•		
Expanded quadratic			•	
Module				
Plate mounting	0.6 kg	0.7 kg	0.7 kg	0.7 kg
Plug-in	0.6 kg	0.7 kg	0.7 kg	0.7 kg
Rack	10 E / 0.5 kg	5 E / 0.3 kg	5 E / 0.3 kg	5 E / 0.3 kg
Measurement input				
Un Voltage	Direct or on VT: 100/√3 110/√3 115/√3 132/√3 90 100 110 115 127 132 138 180 220 250 300 360 380 440 Vac			
Frequency	50, 60 or 400 Hz			
Measurement range 0...Xmax	0...1.25 Un	0...1.25 Un	0.8 Un...1.2 Un	0.8 Un...1.2 Un
Consumption	1 kΩ / V	500 Ω / V	500 Ω / V	1 kΩ / V
Analogue output				
Current	0...Ymax Ymin...Ymax	0...1 mA 1...5 mA	0...2.5 mA 2...10 mA	0...5 mA 4...20 mA
Voltage	0...Ymax Ymin...Ymax	0...1 V	0...5 V	0...10 V 1...5 V 2...10 V
Accuracy	0.5%			
Auxiliary supply				
Alternating current	100/√3 110/√3 115/√3 100 110 115 127 Va 220 230 240 380 400 440 Vac			
Direct current	24 48 110 125 220 Vdc			
Protection rating				
Plate mounting	IP 20			
Plug-in	IP 20			
Rack	IP 20			

Parameters to be specified when ordering

TO ORDER

Customized products

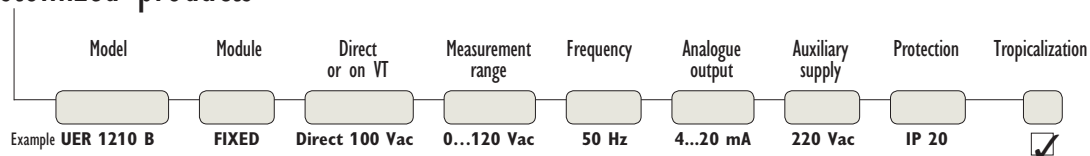

Associated products

19" rack for rack modules

► page 222



Socket connection for plug-in modules

► page 225



DIN rail mounting (fixed panel or plug-in)

► page 225





T82 Range

Measurement and instrumentation Analogue transducers



AC RMS and true RMS Current

Model	IAN 1210 B	IAR 1210 B	IER 1210 B	IQR 1210 B	IAR 1211 B	
Measurement						
RMS	•	•				
True RMS			•	•		
Motor scale					•	
Transfer curve						
Linear	•	•	•			
Expanded					•	
Quadratic				•		
Module						
Plate mounting	0.6 kg	0.7 kg	0.7 kg	0.7 kg	0.7 kg	
Plug-in	0.6 kg	0.7 kg	0.7 kg	0.7 kg	0.7 kg	
Rack	10 E / 0.5 kg	5 E / 0.3 kg	5 E / 0.3 kg	5 E / 0.3 kg		
Measurement input						
Current In	Direct or on CT: 0.5 0.6 1 1.2 1.3 1.5 2.5 5 6 6.5 7 7.5 10 A					Direct or on CT: 1 ou 5 A
Frequency Fn	50, 60 or 400 Hz					
Measurement range 0...Xmax	0...Xmax In < Xmax < 1.3 In				0...1...3 A 0...5...15 A	
Consumption	≤ 2 VA		≤ 0.2 VA			
Analogue output						
Current	0...Ymax	0...1 mA	0...2.5 mA	0...5 mA	0...10 mA 0...20 mA	0...7...10 mA
	Ymin...Ymax		1...5 mA	2...10 mA	4...20 mA	4...15...20 mA
Voltage	0...Ymax		0...1 V	0...5 V	0...10 V	
	Ymin...Ymax		1...5 V	2...10 V		0...7...10 V
Accuracy	0.5 % de 0.5 Un...Un		0.5%			0.5% / 0.1%
Auxiliary supply						
Alternating current		100/√3 110/√3 115/√3	100 110 115 127 220 Vac	100 110 115 127 220 Vac	230 240 380 400 440 Vac	
Direct current			24 48 110 125 220 Vdc			
Self-powered	•					
Protection rating						
Plate mounting						IP 20
Plug-in						IP 20
Rack						IP 20

Parameters to be specified when ordering

TO ORDER

Model	Module	In	Measurement range	Frequency	Analogue output	Auxiliary supply	Protection	Tropicalization	Reference
IAN 1210 B	Fixed	Direct: 5 A	0...5 A	50 Hz	0...10 mA	self-powered	IP 20	without	IANA 3001
		Direct: 5 A	0...5 A	50 Hz	0...10 mA	self-powered	IP 20	without	IANA 3002
IAR 1210 B	Fixed	Direct: 5 A	0...5 A	50 Hz	4...20 mA	220 V / 50 Hz	IP 20	without	UARD 3001

Customized products

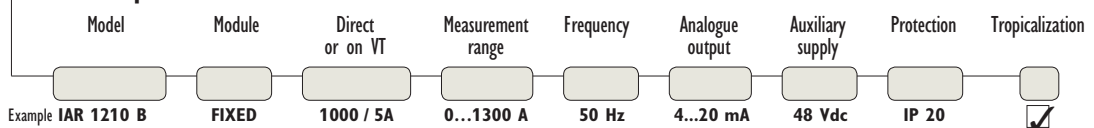

Associated products

19" rack for rack modules

▶ page 222



Socket connection for plug-in modules

▶ page 225



DIN rail mounting (fixed panel or plug-in)

▶ page 225



CT Current transformers

▶ page 90





Frequency



1

ENERGY PERFORMANCE

2

NETWORK QUALITY

3

MEASUREMENT AND INSTRUMENTATION

Model	FAR 1210 B	FCR 1210 B
Measurement		
Measurement type	RMS value	
Input type	Tachometer sensor or mains supply	
Module		
Plate mounting	0.7 kg	0.6 kg
Plug-in	0.7 kg	0.6 kg
Rack	5 E / 0.3 kg	-
Measurement input		
Voltage Un	Direct or on VT: 100/√3 110/√3 Vac 115/√3 100 110 115 Vac 127 230 240 380 400 440 Vac	Direct on VT: 50 to 440 V RMS
Measurement range Xmin...Xmax	45...55 Hz 48...52 Hz 49...51 Hz 350...450 Hz 55...65 Hz 58...62 Hz 59...61 Hz 380...420 Hz	F1 ≥ 30 Hz F1...F2 with 40 Hz <F2<10 kHz et F2/F1 ≥ 1.3
Consumption	1 kΩ / V	
Analogue output		
Transfer curve	Linear	
Current	0...Ymax 0...1 mA 0...2.5 mA 0...5 mA 0...10 mA 0...20 mA Ymin...Ymax 1...5 mA 2...10 mA 4...20 mA	
Voltage	0...Ymax 1...5 V 2...10 V Ymin...Ymax 0...1 V 0...5 V 0...10 V	
Accuracy	0.5%	
Auxiliary supply		
Alternating current	100/√3 110/√3 115/√3 100 Vac 110 115 127 220 230 Vac 240 380 400 440 Vac	100 110 115 127 220 Vac 230 240 380 400 440 Vac
Direct current	24 48 110 125 220 Vdc	24 48 110 125 220 Vdc
Self-powered	•	
Protection rating		
Plate mounting	IP 20	
Plug-in	IP 20	
Rack	IP 20	

Parameters to be specified when ordering

T O O R D E R

Model	Module	Un	Measurement range	Fn	Analogue output	Auxiliary supply	Protection	Tropicalization	Reference
FAR 1210 B	Fixe	Direct: 380 V	45...55 Hz	50 Hz	4...20 mA	220 Vac	IP 20	without	FARD 3000

Customized products

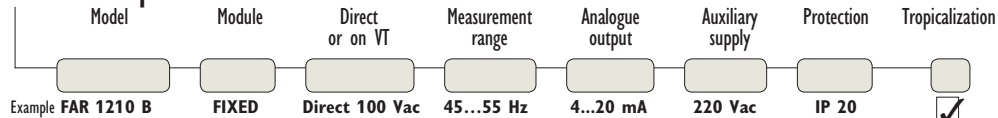

Associated products

19" rack for rack modules

► page 222



Socket connection for plug-in modules

► page 225



DIN rail mounting (fixed panel or plug-in)

► page 225





T82 Range



Power factor



Measurement and instrumentation Analogue transducers

Model	JAR 1211 B	JAR 1231 B
Network + connection		
Single-phase	1 V - 1 I	
Balanced three-phase 3/4 wires		1 U - 1 I
Module		
Plate mounting	0.7 kg	0.7 kg
Plug-in	0.7 kg	0.7 kg
Rack	5 E / 0.3 kg	5 E / 0.35 kg
Measurement input		
Current In	Direct or on VT: 1 ou 5 ou 10 A	
Voltage Un	Direct or on VT: 100/√3 110/√3 115/√3 100 110 115 Vac 127 230 240 380 400 440 Vac	Direct or on VT: 100 110 115 127 230 240 380 400 440 Vac
Measurement range 0...Xmax	0.5 CAP...1... 0.2 IND	0.5 CAP...1...0.5 IND 0.8 CAP...1...0.2 IND
Frequency	50, 60 or 400 Hz	
Consumption	Input I: 0.3 VA Input U: 1 kΩ / V	
Analogue output		
Transfer curve	Linear	
Current 0...Ymax	0...1 mA 0...2 mA 0...2.5 mA 0...5 mA 0...10 mA 0...20 mA	
Ymin...Ymax	4...20 mA	
Voltage 0...Ymax	0...1 V 0...5 V 0...10 V	
Ymin...Ymax	1...5 V 2...10 V	
Accuracy	1%	
Auxiliary supply		
Alternating current	100/√3 110/√3 115/√3 100 110 115 127 220 230 240 380 400 440 Vac	
Direct current	24 48 110 125 220 Vdc	
Self-powered	•	
Protection rating		
Plate mounting	IP 20	
Plug-in	IP 20	
Rack	IP 20	

Parameters to be specified when ordering

TO ORDER

Model	Version	In	Un	Measurement range	Fn	Analogue output	Auxiliary supply	Protection	Tropicalization	Reference
JAR 1231B	Fixe	Direct: 5 A	Direct: 220 V	0.5 CAP...1...0.2 IND	50 Hz	4...20 mA	220 V / 50 Hz	IP 20	without	JARE 3001

Customized products

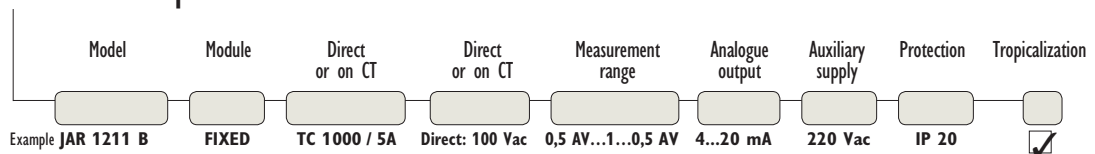

Associated products

19" rack for rack modules

▶ page 222



Socket connection for plug-in modules

▶ page 225



DIN rail mounting (fixed panel or plug-in)

▶ page 225



CT Current transformers

▶ page 90





Synchronization



1 ENERGY PERFORMANCE

2 NETWORK QUALITY

3 MEASUREMENT AND INSTRUMENTATION

Model	JAR 1221 B	UAR 1221 B
Measurement		
Measurement type	Phase shift between two Uac inputs	
Input type	Differential between two Uac inputs (Vac and V ²)	
Module		
Plate mounting	0.7 kg	0.7 kg
Plug-in	0.7 kg	0.7 kg
Rack	5 E / 0.35 kg	-
Measurement input		
Voltage Un	100/√3 110/√3 115/√3 100 110 115 Vac 127 230 240 380 400 440 Vac	
Frequency 0...Xmax	45...55 or 55...65 or 350...450 Hz	
Measurement range	60...0...60° 120...0...120° 150...0...150°	ΔV=± (V1-V2)
Consumption	1 kΩ / V	
Analogue output		
Transfer curve	Linear	
Current	0...Ymax	0...0.5...1 mA 0...1.25...2.5 mA 0...2.5...5 mA 0...5...10 mA 0...10...20 mA
	Ymin...Ymax	4...12...20 mA -1...0...1 mA -2.5...0...2.5 mA -1...0...1 mA -2.5...0...2.5 mA -5...0...5 mA -10...0...10 mA -20...0...20 mA -5...0...5 mA -10...0...10 mA -20...0...20 mA
Voltage	0...Ymax	0...0.5...1 V 0...2.5...5 V 0...5...10 V
	Ymin...Ymax	1...3...5 V -1...0...1 V -1...0...1 V -1...0...1 V -5...0...5 V -10...0...10 V
Accuracy	1%	
Auxiliary supply		
Alternating current	100/√3 110/√3 115/√3 100 110 115 127 220 230 240 380 400 440 Vac	
Direct current	24 48 110 125 220 Vdc	
Self-powered	•	
Protection rating		
Plate mounting	IP 20	
Plug-in	IP 20	
Rack	IP 20	

Parameters to be specified when ordering

TO ORDER

Customized products

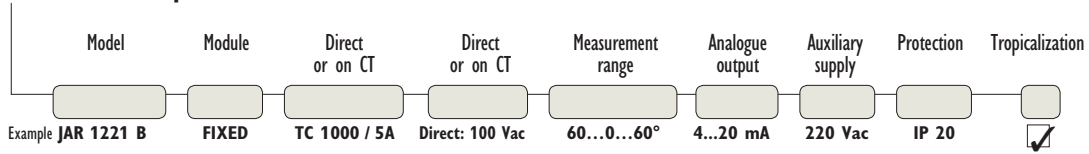

Associated products

- 19" rack for rack modules
▶ page 222

- Socket connection for plug-in modules
▶ page 225

- DIN rail mounting (fixed panel or plug-in)
▶ page 225





T82 Range



Active power



Measurement and instrumentation Analogue transducers

Model	PAR 1211B	PAR 1231B	PAR 1232B	PAR 1233B	PAR 1234B	PAR 1235B
Network + connections						
Single	1V - 1I					
Balanced three-phase 3 wires		1U - 1I			1U - 2I	2U - 1I
Unbalanced three-phase 3 wires			2U - 2I			
Balanced three-phase 4 wires	1V - 1I					
Unbalanced three-phase 4 wires			2U - 3I	3V - 3I		
Model version						
Plate mounting	0.850 kg	0.850 kg	0.850 kg	0.850 kg	0.850 kg	0.850 kg
Plug-in	0.850 kg	0.850 kg	0.850 kg	0.850 kg	0.850 kg	0.850 kg
Rack	5 E / 0.5 kg	10 E / 0.5 kg	10 E / 0.6 kg	10 E / 0.7 kg	5 E / 0.35 kg	5 E / 0.35 kg
Measurement inputs						
Current In	Direct or on CT: 1.5 ou 10 A					
Voltage Un	Direct or on VT: 100/√3 110/√3 115/√3 230 100 110 115 127 220 240 380 400 440	Direct or on VT: 100 110 115 Vac 127 230 240 380 400 440 Vac		Direct or on VT: 100/√3 110/√3 Vac 115/√3 230 Vac	Direct or on VT: 100 110 115 Vac 127 230 240 380 400 440 Vac	
Frequency	50, 60 or 400 Hz					
Measurement range	0...Xmax or Xmin...Xmax with 0.5 Sn ≤ Xmax ≤ 1.35 Sn (1)					
Consumption	Input I: 0.2 VA			Input U > 500 Ω / V		
Analogue output						
Transfer curve	Linear					
Current	0...Ymax	0...1 mA 0...2.5 mA 0...5 mA 0...10 mA 0...20 mA				
	Ymin...Ymax	-1...0...1 mA -2.5...0...2.5 mA -5...0...5 mA -10...0...10 mA -20...0...20 mA 1...5 mA 2...10 mA 4...20 mA 1...3...5 mA 2...6...10 mA 4...12...20 mA				
Voltage	0...Ymax	0...1 V 0...5 V 0...10 V				
	Ymin...Ymax	-1...0...1 V -5...0...5 V -10...0...10 V 1...5 V 2...10 V				
Accuracy	Class 0.5: 0.75 Sn ≤ Xmax ≤ 1.35 Sn			Class 1: 0.5 Sn ≤ Xmax < 0.75 Sn		
Auxiliary supply						
Alternating current	100/√3 110/√3 115/√3 100 110 115 127 220 230 240 380 400 440 Vac					
Direct current	24 48 110 125 220 Vdc					
Self-powered	•	•	•	•	•	•
Protection rating						
Plate mounting	IP 20					
Plug-in	IP 20					
Rack	IP 20					

(1) $S_n = V \times I \times \cos \varphi$ (single-phase network) $S_n = 3 \times V \times I \times \cos \varphi$
 (Balanced three-phase, Unbalanced three-phase 4 wires)
 $S_n = \sqrt{3} \times U \times I \times \cos \varphi$ (Balanced three-phase, Unbalanced three-phase 3 wires)

Parameters to be specified when ordering

TO ORDER

Model	Version	Direct or on CT	Direct or on VT	Measurement range	Frequency	Analogue output	Auxiliary supply	Protection	Tropicalization	Reference
PAR 1232	B Panel mounted	Direct: 5 A	Direct: 380 V	0...3 kW	50 Hz	4...20 mA	220 V / 50 Hz	IP 20	without	PQRE 3001
PAR 1232	B Panel mounted	Direct: 5 A	Direct: 100 V	0...866 W	50 Hz	4...20 mA	220 V / 50 Hz	IP 20	without	PQRE 3002
PAR 1233	B Panel mounted	Direct: 5 A	Direct: 380 V	0...3 kW	50 Hz	4...20 mA	220 V / 50 Hz	IP 20	without	PQRF 3001
PAR 1233	B Panel mounted	Direct: 5 A	Direct: 380 V	0...3 kW	50 Hz	4...20 mA	220 V / 50 Hz	IP 20	without	PQRC 3003
PAR 1235	B Panel mounted	Direct: 5 A	Direct: 220 V	0...1 kW	50 Hz	4...20 mA	220 V / 50 Hz	IP 20	without	PQRC 3001
PAR 1211	B Panel mounted	Direct: 5 A	Direct: 220 V	0...3 kW	50 Hz	4...20 mA	220 V / 50 Hz	IP 20	without	PQRC 3002

Customized products

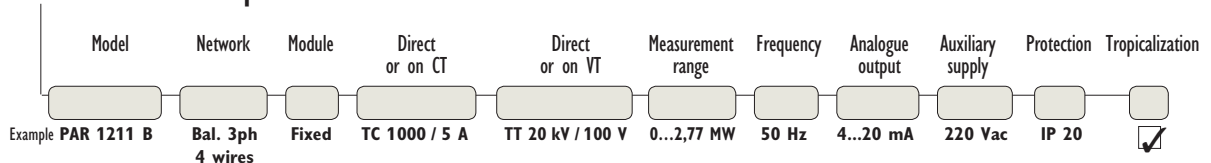



Reactive power



1

ENERGY PERFORMANCE

2

NETWORK QUALITY

3

MEASUREMENT AND INSTRUMENTATION

Model	QAR 1211B	QAR 1211B	QAR 1232B	QAR 1233B	QAR 1234B
Network + connections					
Single	1V - 1I				
Balanced three-phase 3 wires		1U - 1I			1U - 2I
Unbalanced three-phase 3 wires			2U - 2I		
Balanced three-phase 4 wires	1V - 1I				
Unbalanced three-phase 4 wires			2U - 3I	3U - 3I	
Model version					
Plate mounting	0.850 kg	0.850 kg	0.850 kg	0.850 kg	0.850 kg
Plug-in	0.850 kg	0.850 kg	0.850 kg	0.850 kg	0.850 kg
Rack	5 E / 0.5 kg	10 E / 0.5 kg	10 E / 0.6 kg	10 E / 0.7 kg	5 E / 0.35 kg
Measurement inputs					
Current In	Direct or on CT: 1.5 or 10 A				
Voltage Un	Direct or on VT: 100/√3 110/√3 115/√3 230 single-phase only: 100 110 115 127 220 240 380 400 44	Direct or on VT: 100 110 115 127 230 240 380 400 440 Vac			Direct or on VT: 100/√3 110/√3 Vac 115/√3 230 Vac
Frequency	50, 60 or 400 Hz				
Measurement range Xmin...Xmax	0...Xmax or Xmin...Xmax with 0.5 Sn ≤ Xmax ≤ 1.35 Sn (1)				
Consumption	Input I: 0.2 VA Input U > 500 Ω / V				
Analogue output					
Transfer curve	Linear				
Current	0...Ymax	0...1 mA 0...2.5 mA 0...5 mA 0...10 mA 0...20 mA			
	Ymin...Ymax	-1...0...1 mA -2.5...0...2.5 mA -5...0...5 mA -10...0...10 mA -20...0...20 mA 1...5 mA 2...10 mA 4...20 mA 1...3...5 mA 2...6...10 mA 4...12...20 mA			
Voltage	0...Ymax	0...1 V 0...5 V 0...10 V			
	Ymin...Ymax	-1...0...1 V -5...0...5 V -10...0...10 V 1...5 V 2...10 V			
Accuracy	Class 0.5: 0.75 Sn ≤ Xmax ≤ 1.35 Sn Class 1: 0.5 Sn ≤ Xmax < 0.75 Sn				
Auxiliary supply					
Alternating current	100/√3 110/√3 115/√3 100 110 115 127 220 230 240 380 400 440 Vac				
Direct current	24 48 110 125 220 Vdc				
Self-powered	• • • • •				
Protection rating					
Plate mounting	IP 20				
Plug-in	IP 20				
Rack	IP 20				

(1) $S_n = V \times I \times \sin \varphi$ (single-phase network) $S_n = 3 \times V \times I \times \sin \varphi$ (Balanced three-phase, Unbalanced three-phase 4 wires)
 $S_n = \sqrt{3} \times U \times I \times \sin \varphi$ (Balanced three-phase, Unbalanced three-phase 3 wires)

Parameters to be specified when ordering

T O O R D E R

Model	Version	Direct or on CT	Direct or on VT	Measurement range	Frequency	Analogue output	Auxiliary supply	Protection	Tropicalization	Reference
QAR 1232 B	mounted	Direct: 5 A	Direct: 380 V	0...3 kvar	50 Hz	4...20 mA	220 V / 50 Hz	IP 20	without	PQRE 3003
QAR 1232 B	mounted	Direct: 5 A	Direct: 100 V	0...866 var	50 Hz	4...20 mA	220 V / 50 Hz	IP 20	without	PQRE 3004

Customized products

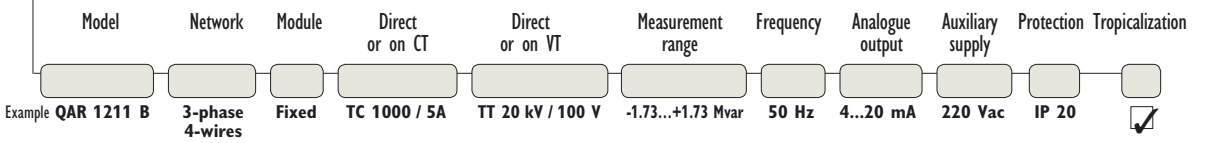

Associated products

- 19" rack for rack modules
 ▶ page 222
- Socket connection for plug-in modules
 ▶ page 225
- DIN rail mounting (fixed panel or plug-in)
 ▶ page 225
- CT Current transformers
 ▶ page 90



T82 Range



DC Voltage / Summation



Measurement and instrumentation Analogue transducers

Model	UCR 1220 B	UCR 1420 B (1)	UCR 1230 B	UCR 1216 B
Measurement				
DC Voltage	•	•	•	
Summation of DC voltage				•
Transfer curve				
Linear	•	•		•
Extended			•	
Module				
Plate mounting	0.7 kg	0.7 kg	0.7 kg	0.7 kg
Plug-in	0.7 kg	0.7 kg	0.7 kg	0.7 kg
Rack	5 E / 0.3 kg	5 E / 0.3 kg	5 E / 0.3 kg	5 E / 0.3 kg
Voltage inputs				
Voltage U_n	$5 \text{ mV} \leq U_n \leq 650 \text{ Vdc}$	$5 \text{ mV} \leq U_n \leq 1500 \text{ Vdc}$	$5 \text{ mV} \leq U_n \leq 130 \text{ Vdc}$	Summation of 2 to 6 inputs U with $0.1 \text{ V} \leq U_n \leq 20 \text{ Vdc}$ or $1 \dots 5 \text{ V}$ $2 \dots 10 \text{ Vdc}$
Measurement range $0 \dots X_{\text{max}}$	$0 \dots \pm U_n$ or $U_{n1} \dots U_{n2}$ with $U_{n2} > 2 \times U_{n1}$		$0 \dots U_n \dots 5 U_n$	$U_{n1} + U_{n2} + U_{n3} + U_{n4} + U_{n5} + U_{n6}$
Input resistance				$> 100 \text{ k}\Omega$
Analogue output				
Transfer curve	Linear			
Current $0 \dots Y_{\text{max}}$	$0 \dots 1 \text{ mA}$ $0 \dots 2.5 \text{ mA}$ $0 \dots 5 \text{ mA}$ $0 \dots 10 \text{ mA}$ $0 \dots 20 \text{ mA}$			
$Y_{\text{min}} \dots Y_{\text{max}}$	$1 \dots 5 \text{ mA}$ $2 \dots 10 \text{ mA}$ $4 \dots 20 \text{ mA}$			
Voltage $0 \dots Y_{\text{max}}$	$0 \dots 1 \text{ V}$ $0 \dots 5 \text{ V}$ $0 \dots 10 \text{ V}$			
$Y_{\text{min}} \dots Y_{\text{max}}$	$1 \dots 5 \text{ V}$ $2 \dots 10 \text{ V}$			
Accuracy	Class 0.5	Class 0.5	Class 0.5 / 1	Class 0.5
Auxiliary supply				
Alternating current	100 110 115 127 220 230 240 380 Vac			
Direct current	24 48 110 125 220 Vdc			
Protection rating				
Plate mounting				IP 20
Plug-in				IP 20
Rack				IP 20

(1) insulation: 4 kV

Parameters to be specified when ordering

TO ORDER

Model	Version	Measurement range	Analogue output	Auxiliary supply	Protection rating	Tropicalization	Reference
UCR 1220 B	Fixed	$0 \dots 10 \text{ Vdc}$	$0 \dots 10 \text{ Vdc}$	220 V / 50 Hz	IP 20	without	UCRG 3001

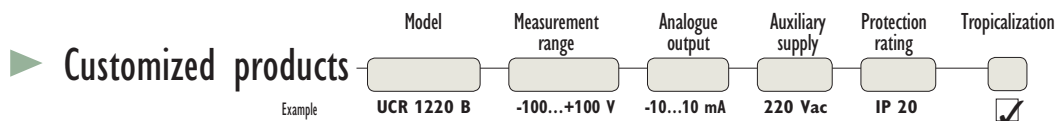

► Associated products

19" rack for rack modules

► page 222



Socket connection for plug-in modules

► page 225



DIN rail mounting (fixed panel or plug-in)

► page 225



Shunts

► page 91





DC Current / Summation



1 ENERGY PERFORMANCE

2 NETWORK QUALITY

3 MEASUREMENT AND INSTRUMENTATION

Model	UCR 1220 B	UCR 1420 B (1)	UCR 1230 B	UCR 1216 B
Measurement				
DC current	•	•	•	
Summation of DC current				•
Transfer curve				
Linear	•	•		•
Extended			•	
Module				
Plate mounting	0.7 kg	0.7 kg	0.7 kg	0.7 kg
Plug-in	0.7 kg	0.7 kg	0.7 kg	0.7 kg
Rack	5 E / 0.3 kg	5 E / 0.3 kg	5 E / 0.3 kg	5 E / 0.3 kg
Current inputs				
Current I _n	5 μA ≤ I _n ≤ 100 mA		5 μA ≤ I _n ≤ 20 mA	Summation of 2 to 6 inputs I with 1 mA ≤ I ≤ 20 mA or 1...5 mA 2...10 mA 4...20
Measurement range 0...X _{max}	0...±I _n		0...I _n ...5I _n	I _{n1} +I _{n2} +I _{n3} +I _{n4} +I _{n5} +I _{n6}
Input resistance	0.1V/I _n			1V/I _n
Analogue output				
Transfer curve	Linear			
Current	0...Y _{max}	0...1 mA 0...2.5 mA 0...5 mA 0...10 mA 0...20 mA		
	Y _{min} ...Y _{max}	1...5 mA 2...10 mA 4...20 mA		
Voltage	0...Y _{max}	0...1 V 0...5 V 0...10 V		
	Y _{min} ...Y _{max}	1...5 V 2...10 V		
Accuracy	Class 0.5	Class 0.5	Class 0.5 / 1	Class 0.5
Auxiliary supply				
Alternating current	100 110 115 127 220 230 240 380 Vac			
Direct current	24 48 110 125 220 Vdc			
Protection rating				
Plate mounting				IP 20
Plug-in				IP 20
Rack				IP 20

(1) insulation:4 kV

Parameters to be specified when ordering

TO ORDER

Model	Version	Measurement range	Analogue output	Auxiliary supply	Protection rating	Tropicalization	Reference
ICR 1220 B	Fixed	4 to 20 mA	4 to 20 mA	220 V / 50 Hz	IP 20	without	UCRG 3002

► **Customized products**

Example

Model	Version	Measurement range	Analogue output	Auxiliary supply	Protection rating	Tropicalization
ICR 1220 B	Fixe	0...20 mA	4...20 mA	220 Vac	IP 20	<input checked="" type="checkbox"/>

► Associated products

19" rack for rack modules

► page 222



Socket connection for plug-in modules

► page 225



DIN rail mounting (fixed panel or plug-in)

► page 225



Shunts

► page 91

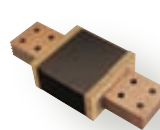



T82 Range



Temperature



Measurement and instrumentation Analogue transducers

Model	TCL 1220 B							RCL 1220B					
Version													
Plate mounting	0.7 kg							0.7 kg					
Plug-in	0.7 kg							0.7 kg					
Rack	5 E / 0.3 kg							5 E / 0.3 kg					
Measurement input													
Type: thermocouple / probe	K	T	J	E	R	S	B	platinum	copper				
Couple break protection	Max. output or min. output												
Mounting								2, 3 or 4 wires					
Measurement range Xmin...Xmax	-200...1200°C	-200...350°C	-200...600°C	-200...1000°C	0...1750°C	600...1800°C	600...1800°C	0...500°C	0...200°C				
Input resistance for CT	> 50 k Ω												
Current in probe								2 mA max	3 mA				
Line resistance	0 - 200							0 - 10 Ω					
Calibration resistance	100 Ω												
Analogue output													
Transfer curve	Linear												
Current	0...Ymax	0...1 mA 0...2.5 mA 0...5 mA 0...10 mA 0...20 mA											
	Ymin...Ymax	1...5 mA 2...10 mA 4...20 mA											
Voltage	0...Ymax	0...1 V 0...5 V 0...10 V											
	Ymin...Ymax	1...5 V 2...10 V											
Accuracy	Class 0.5 - Class 1 - Class 1.5							Class 0.5					
Auxiliary supply													
Alternating current	100/√3	110/√3	115/√3	100	110	115	127	220	230	240	380	400	440 Vac
Direct current	24 48 110 125 220 Vdc												
Protection rating													
Plate mounting								IP 20					
Plug-in								IP 20					
Rack								IP 20					

Parameters to be specified when ordering

TO ORDER

Customized products

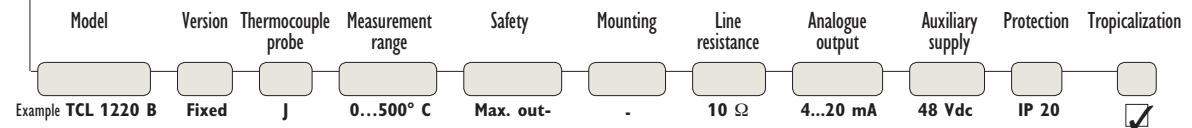

Associated products

19" rack for rack modules

► page 222



Socket connection for plug-in modules

► page 225



DIN rail mounting (fixed panel or plug-in)

► page 225



Thermocouple/probe

► Pyro-Contrôle Catalogue





Resistance



1 ENERGY PERFORMANCE

2 NETWORK QUALITY

3 MEASUREMENT AND INSTRUMENTATION

Model	RCR 1211 B				
Version					
Plate mounting	0.7 kg		0.7 kg		
Plug-in	0.7 kg		0.7 kg		
Measurement input					
Type	Potentiometer		Rheostat		
Measurement range 0...Xmax	0...R with $1\text{ k}\Omega \leq R \leq 5\text{ k}\Omega$		0...R with $100 \leq R \leq 5000\ \Omega$		
Sensor break protection	Max. output or min. output				
Sensor current	3 mA for $R \leq 300\ \Omega$ or $I = 1\text{ V/R}$ for $R > 300\ \Omega$				
High dead end resistance	Max. value: 10% of Xmax				
Low dead end resistance	Max. value: 10% of Xmax				
Analogue output					
Transfer curve	Linear				
Current	0...Ymax	0...1 mA 0...2.5 mA 0...5 mA 0...10 mA 0...20 mA			
	Ymin...Ymax	1...5 mA 2...10 mA 4...20 mA			
Voltage	0...Ymax	0...1 V 0...5 V 0...10 V			
	Ymin...Ymax	1...5 V 2...10 V			
Accuracy	Class 0.5				
Auxiliary supply					
Alternating current	100/√3 110/√3 115/√3 100 110 115 127 220 230 240 380 400 440 Vac				
Direct current	24 48 110 125 220 Vdc				
Protection rating					
Plate mounting	IP 20				
Plug-in	IP 20				

Parameters to be specified when ordering

TO ORDER

Customized products

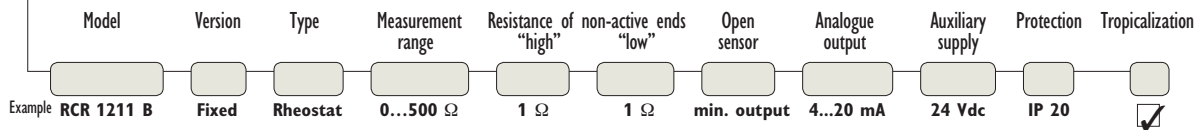

Associated products

19" rack for rack modules

▶ page 222



Socket connection for plug-in modules

▶ page 225



DIN rail mounting (fixed panel or plug-in)

▶ page 225





MODUL'M Range

Industrial transducers

Measurement and instrumentation Industrial transducers

PRODUCT ADVANTAGES

- + Modular, **UPGRADABLE SYSTEM**
- + Totally **USER-PROGRAMMABLE** via a PC
- + Built-in **MAINTENANCE FUNCTIONS**
- + **RS 485 MODBUS RTU COMMUNICATION** interface up to 38,400 bauds
- + Quick, simple **DIN-RAIL OR WALL MOUNTING**



Large-size terminals ensure safety and accessibility

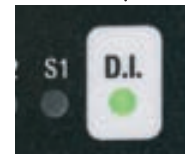

Each transducer is equipped with an internal fault relay

► Description

The industrial transducers in the **MODUL'M** range form a modular acquisition system made up of logical or analogue input-output modules.

Each module is equipped with a power supply isolated from its inputs-outputs and a digital communication link. This concept allows you to set up transducers as close as possible to the sensors so that the measurement data can then be circulated in digital form without alteration, even over long distances.

Each instrument includes an internal fault relay guaranteeing operating safety. This relay may be activated in the event of sensor breakage, interruption of the digital link or power outage.

MTAC Tachometry



- Speed measurement transducer
- Can be coupled with inductive or magnetic sensors to set up a tachometric measurement line with a threshold function
- 2 relays extendable to 7 with the MREL5 extension
- Transmission of speed / frequency in analogue form (U/I) and in digital form on the RS485 link

Model	Reference
MTAC	A25120

MREL5 Extension



- Relay or thres hold extension unit
- 5 relays + 1 DI relay
- Programmable as a ModBus slave controlled by an MTAC module or a CM100 power monitor
- Programmable as a ModBus logic controller to read a measurement transducer and refresh the relay outputs via the RS485 link

Model	Reference
MIREL5	A25122

MTAC-t Frequency



- Frequency measurement transducer
- Connected to a 600 V (Cat. III) maximum AC link to set up a frequency acquisition line with a threshold function
- 2 relays extendable to 7 with the MREL5 extension
- Transmission of frequency in analogue form (U/I) and in digital form on the RS485 link

Model	Reference
MTAC-t	A25121

MEA3 Process, temperature 3 channels, 2 relays



- Multi-purpose acquisition unit
- 3 analogue channels (current, voltage, Pt100, thermocouples, etc.)
- Scaling of each measurement channel
- 2 relays for programmable monitoring threshold functions on each channel
- Transmission of the measurements in digital form on the RS485 link

Model	Reference
MEA3	A25123

► Associated products

CM100 Digital data processors

► contact us



CM100D Meteorological data processors

► contact us



1
ENERGY
PERFORMANCE

2
NETWORK
QUALITY

3
MEASUREMENT AND
INSTRUMENTATION



MODUL'M Range

Industrial transducers

Measurement and instrumentation Industrial transducers

MEA7 Process, temperature 7 channels, 1 relay



- Multi-purpose acquisition unit
- 7 analogue channels (current, voltage, Pt100, thermocouples, etc.)
- Scaling on each measurement channel
- 1 relay for programmable monitoring threshold functions on each channel
- Transmission of the measurements in digital form on the RS485 link

Model	Reference
MEA7	A25124

MSA4 Analogue outputs



- Analogue output extension unit
- 4 U or I outputs
- Retrieval of the data from the digital link and conversion into analogue form
- Programmable as a ModBus slave controller by a PLC or a CM100 power monitor via the RS485 link
- Programmable as a ModBus logic controller to read a measurement transducer and refresh the analogue outputs via the RS485 link

Model	Reference
MSA4	A25125

MES16 Logical inputs / outputs



- Logical input/output acquisition unit
- 16 configurable channels (16 inputs or 8 inputs / 8 outputs or 16 outputs)
- Seen as a ModBus slave controlled by a PLC or a CM100 power monitor via the RS485 link

Model	Reference
MES16	A25126

► Dimensions (in mm)

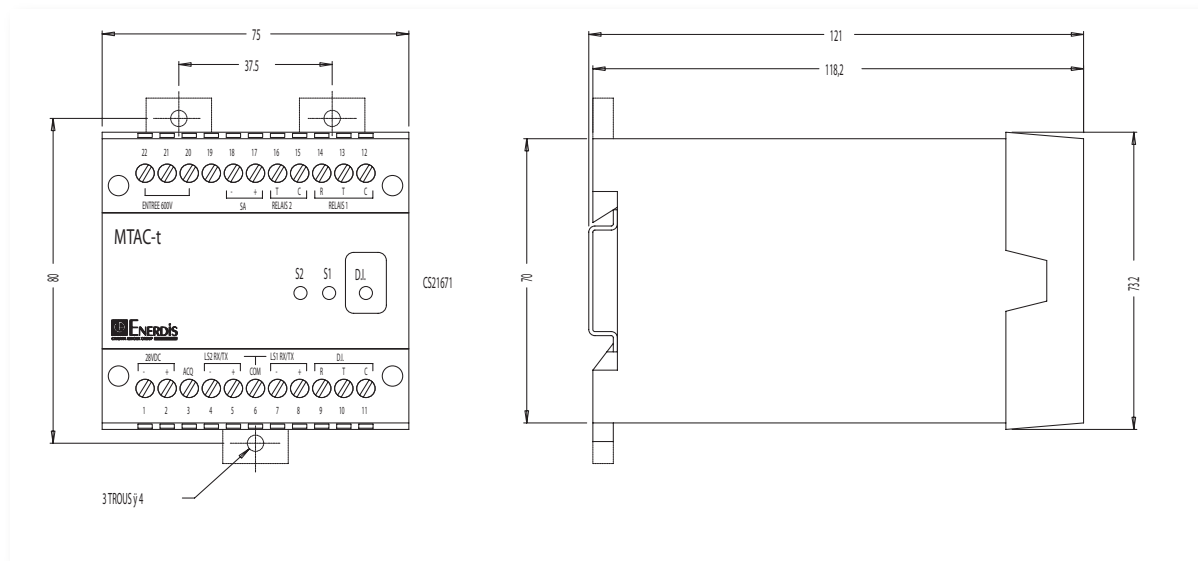

► Technical specifications

Model	MTAC	MTAC-t	MRELS	MEA3	MEA7	MSA4	MES16
Input							
	1 speed input + 1 rotation-direction input	1 frequency input	-	3 programmable inputs	7 programmable inputs	-	16 programmable logical inputs
Resistance thermometer				200... +850°C 2/3 wires pt100	200... +850°C 2/3 wires pt100		
Thermocouple				B.E.J.K.N.R.S.T	B.E.J.K.N.R.S.T		
Cold junction compensation by Pt 100 assembly				on input 3	on input 7		
Current				0... ± 20 mA	0... ± 20 mA		
Voltage				0... ± 10 V	0... ± 10 V		
Tachometric input	Inductive or magnetic sensors for speed and rotation direction	Voltage from 5 to 600 V					
Output							
Analogue output programmable for voltage (0...± 10 V) or current (0... ± 20 mA)	1	1				4	
Logical outputs							16 programmable outputs
Relays: Internal fault Alarm	1 2	1 2	1 5	1 2	1 1	1 2	1 1
Digital link							
RS485 / ModBus RTU	slave	slave	master/slave	slave	slave	master/slave	slave
Auxiliary power supply							
DC	12 to 35 Vdc						
Consumption	3 W	3 W	3 W	3 W	3 W	4.5 W	3 W

► Accuracy

Model	MTAC	MTAC-t	MRELS	MEA3	MEA7	MSA4	MES16
Input							
Pt 100 basic accuracy	50.10 ⁻⁴	50.10 ⁻⁴		0.05% end of scale ± 0.1° C	0.05% end of scale ± 0.1° C		
Basic accuracy in mA				2.10 ⁻⁴	2.10 ⁻⁴	0.1% end of scale	
Basic accuracy in Vdc				2.10 ⁻⁴	2.10 ⁻⁴	0.1% end of scale	
Temperature coefficient	50 ppm°C	50 ppm°C		50 ppm°C	50 ppm°C	150 ppm°C	
Response time	20 ms	20 ms	programmable	100 or 420 ms	200 ms or 1 s	30 ms	Reading of input in 20 ms

1
ENERGY
PERFORMANCE

2
NETWORK
QUALITY

3
MEASUREMENT AND
INSTRUMENTATION



MODUL'M Range

Measurement and instrumentation Industrial transducers

► Mechanical specifications

Model	MTAC	MTAC-t	MRELS	MEA3	MEA7	MSA4	MES16
Casing							
Material	Polycarbonate						
Dimensions L x D x H (mm)	75 x 120 x 73						
Mounting	Symmetrical DIN bar or wall-mounting						
Weight (kg)	0.3						
Connection	Screw terminals				Screw terminals and female 25-pin SUBD connector	Screw terminals	Screw terminals and male 25-pin SUBD connector

► Environment

Operating temperature	-10 to +60°C
Storage temperature	-25 to +70°C
Leakproofing	IP20
EMC	Complies with the IEC 61326-1 standard

ENERTRACE Range

«Plug & Play» paperless recorder

PRODUCT ADVANTAGES

- + **VERY-HIGH-RESOLUTION TFT VGA SCREEN, 6.4", 256 colours**
- + **Up to 18 CONFIGURABLE MEASUREMENT CHANNELS**
- + **Data backup on Compact Flash card (up to 1 GB)**
- + **ETHERNET link and PROCESSING SOFTWARE provided as standard**



32 MB memory card as standard



6 slots for 3 types of input/output cards (logical, relay, analogue)



Portable version available

► Description

ENERTRACE is a "plug & play" paperless recorder suitable for all types of processes. It is equipped with an 18-bit converter for optimum measurement accuracy and a polling rate of 200 ms per channel.

- Inputs / outputs which can be configured and extended: up to 18 analogue measurement channels (mV, V, mA, T°, etc.) or 12 isolated and configurable logical inputs and up to 12 relay outputs, depending on the combinations.
- Computer processing of the data via a PC link
- Remote adjustment and configuration via an RS232, RS485 or Ethernet link
- Recording of data over a period of several months
- Simplified maintenance due to the absence of parts subject to wear or requiring replacement (paper, pens, etc.)
- Auxiliary power supply with broad dynamic range: 90 to 264 Vac / 11 to 370 Vdc

► Display



Bargraph mode

Vertical display of 6 bargraphs. Configurable scale for each bargraph. Bars identified by colour and process label. High and low alarms marked "Hi/Lo".

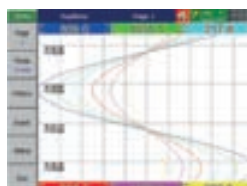

Graphic curves mode

Vertical or horizontal display of 6 curves in real time. Simple switching from one page to another using the "Page" function. Constant display of the date and time, as well as a pictogram if there is an alarm or the memory is full.

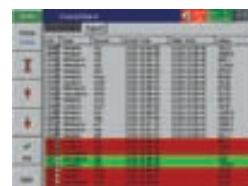

Log of alarms

Display of all time / date-stamped alarms. "Browse" function for choosing the alarms to be cleared. Different colours for different alarm statuses.

1
ENERGY PERFORMANCE

2
NETWORK QUALITY

3
MEASUREMENT AND INSTRUMENTATION

► Electrical specifications

Auxiliary power supply

Alternating current, operating domain and consumption:
90... 264 Vac, 47...63 Hz, 60 VA, 30 W max.
Direct current, operating domain and consumption:
11...370 Vdc, 60 VA, 30 W max.

Analogue input board

Channels: 3 per card
Resolution: 18 bits
Polling rate: 200 ms
Maximum value: -2 Vdc min., 12 Vdc max. (for standard board)
Temperature drift:
±1.5 µV/°C - except for mA inputs; ±3.0 µV/°C for mA inputs
Influence of line resistance:
TC : 0.2 µV/Ω and 3-wire Pt100: 2.6°C/Ω. of difference between 2 branches
Sensor break-induced current: 200 nA
Common-mode rejection: 120 dB
Serial-mode rejection: 55 dB
Insulation voltage between channels: 430 Vac
Sensor failure detection: sensor open-circuit for TC, Pt100 and mV inputs
- below 1 mA for the 4-20 mA input
- below 1 mA for the 4-20 mA input
- not applicable to the other inputs
Response time after sensor failure:
0.1 sec for 4-20 mA and 1.5 V and 10 sec for CT, Pt100 and mV

Type	Scale	Accuracy at 25°C	Impedance
Analogue input board, negative U/I			
-20 +20 mA	-22 ... +22 mA	± 0.1%	70.5 Ω
-60 +60 mVdc	-62 ... +62 mVdc	± 0.1%	2.2 MΩ
-2 + 2 Vdc	-2.2 ... +2.2 Vdc	± 0.1%	332 kΩ
20 +20 Vdc	-22 ... +22 Vdc	± 0.1%	332 kΩ
Standard analogue input board			
mV	-8 ... 70 mV	±0.05%	2.2 MΩ
mA	-3 ... 27 mA	±0.05%	70.5 Ω
V	-0.12 ... 1.15 V	±0.05%	332 kΩ
0/5 V	-1.3 ... 11.5 V	±0.05%	332 kΩ
1/5 V	-1.3 ... 11.5 V	±0.05%	332 kΩ
0/10 V	-1.3 ... 11.5 V	±0.05%	332 kΩ
J*	120 ... 1 000°C	±1°C	2.2 MΩ
K*	-200 ... 1 370°C	±1°C	2.2 MΩ
Pt100 (DIN)*	-210 ... 700°C	±0.4°C	1.3 kΩ

* Other types of temperature probes: please contact us

Logical input boards

Channels: 6 per board
Low level: -5 V minimum, 0.8 V max.
High level: 2 V minimum, 5 V max.
External pull-down resistance: 1Ω max.
External pull-up resistance: 1.5 MΩ min.

Relay output boards

Relays: 6 per boards
Contact type: N.O (normally open)
Relay type: 5 A/240 Vac
Number of cycles: 200,000 resistive load

Analogue current output boards

Measurement input transcription card with function for possible multiplication, addition or subtraction of inputs
Type: 0-20 mA and 4-20 mA

► Communication

Serial communication module

Interface	RS232 - RS422 or RS485
Protocol	ModBus RTU
Address	1 to 247
Speed	0.3 to 38.4 kbits/s
Data bits	7 or 8 bits
Parity bit	none, even or odd
Stop bit	1 or 2 bits

ETHERNET communication module

Protocol	ModBus TCP/IP, 10BaseT with automatic polarity correction
Ports	AUI and RJ-45 with auto-detection capability

► Environment

Operating temperature	+5°C to +50°C
Storage temperature	-25°C to +60°C
Relative humidity	20 to 80% RH
Insulation resistance	20 MΩ min. (at 500 Vdc)
Dielectric strength	3 kVac at 50 / 60 Hz for 1 minute
Vibration resistance	10-55 Hz, 10 m/s ² for 2 hours
Shock resistance	3 m/s ² (3 g) in operation, 100 g during transport
Infrared sensor	detection of human presence up to 2 m away (screen saver)
Weight	1.9 kg

► Standards

Safety	UL873 (11 th edition 1994) CSA: C22.2 N° 24-93 CE: EN61010-1 (IEC 1010-1) Overvoltage category II, pollution degree 2
Protection class for indoor use	Cabinet front panel IP30, wiring IP20
EMC emission	EN50081-2. EN61326 (EN55011 class B. EN61000-3-2. EN61000-3-3)
Immunity	EN50082-2. EN61326 (EN61000-4-2. EN61000-4-3. EN61000-4-4. EN61000-4-5. EN61000-4-6. EN61000-4-11. EN50204)

► Configuration software

TracerManager 1: configuration and retrieval of historical data on PC
TracerManager 2: configuration, retrieval and display of real-time data on PC
Minimum configuration required: PC 200 MHz - 64 MB RAM

► Electrical connections

Analogue inputs

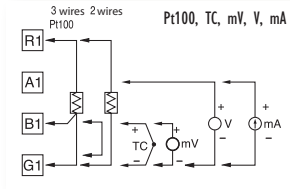

Logical inputs

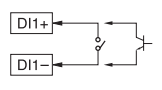

Analogue outputs

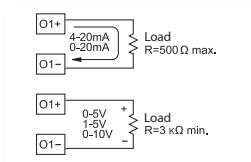

Relay outputs

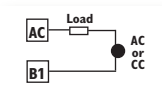

► Dimensions

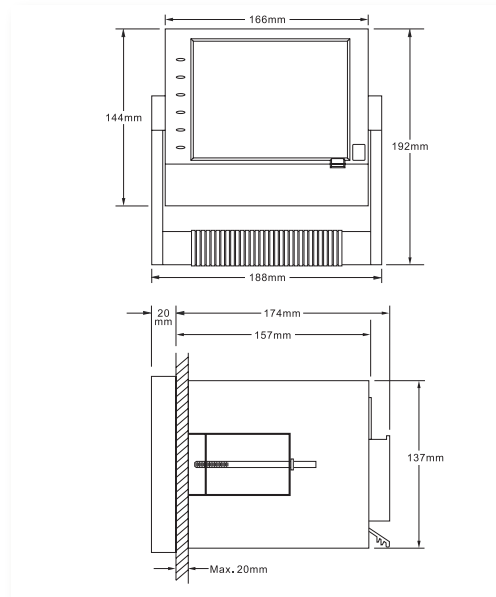

► Panel cut-outs

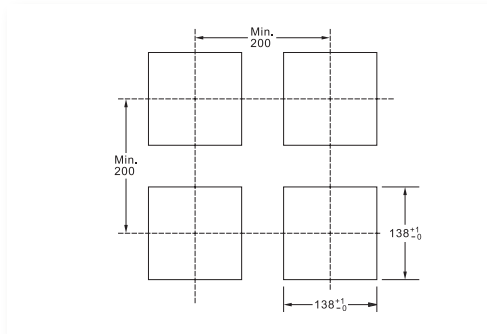

1
ENERGY
PERFORMANCE

2
NETWORK
QUALITY

3
MEASUREMENT AND
INSTRUMENTATION

► Associated products

Transducers

► page 192



CT Current transformers

► page 90





ENERTRACE Range

Paperless process recorder

Graphic recorders

Measurement and instrumentation

TO ORDER

ENERTRACE



1 Power supply		Code
4 90-264 Vac 47-63 Hz /110-370 Vdc	_____	standard
6 11-18 Vdc		
7 18-36 Vdc		
8 36-72 Vdc		
2 Analogue inputs		LR00112-000*
0 no analogue input	0 slot	
3 3 analogue inputs	1 slot	
6 6 analogue inputs	2 slots	
A 9 analogue inputs	3 slot	
B 12 analogue inputs	4 slots	
C 15 analogue inputs	5 slots	
D 18 analogue inputs	6 slots	
3 Logical inputs		LR00113-000*
0 no logical input	0 slot	
1 6 logical inputs	1 slot	
2 12 logical inputs	2 slots	
4 Relay outputs		LR00114-000*
0 no relay	0 slot	
1 6 relays	1 slot	
2 12 relays	2 slots	
5 Communication		standard
0 via Ethernet		
1 RS232/422/485 (3 in 1) + Ethernet interface		
6 Configuration software		standard
1 "TracerManager1"		
7 ENERTRACE software		
0 basic version		
1 calculation, counter and totalizer functions		
8 Compact Flash		standard
1 256 MB		
9 ENERTRACE mounting		standard
1 version for cabinet mounting		
2 portable version with carrying handle		
10 Option		
0 no option		
1 24 Vdc power supply for transmitters (6 max.) [1 slot]		LR00115-000*
11 Analogue outputs		LR00123-000*
0 no analogue output	0 slot	
3 3 analogue mA outputs	1 slot	
6 6 analogue mA outputs	2 slots	
A 9 analogue mA outputs	3 slots	
12 Negative U/I analogue inputs		LR00128-000*
0 no negative U/I input	0 slot	
3 3 negative U/I inputs	1 slot	
6 6 negative U/I inputs	2 slots	
A 9 negative U/I inputs	3 slots	
B 12 negative U/I inputs	4 slots	
C 15 negative U/I inputs	5 slots	
D 18 negative U/I inputs	6 slots	

ACCESSORIES:

"TracerManager2" software	_____	LR00132-000*
1 GB Compact Flash memory	_____	LR00121-000*
Flash/USB adapter	_____	LR00127-000*

*Can be sold separately



Measurement and Instrumentation

Synchronization instruments

Synchronization instruments
SYNCHRO COUPLER range

p. 248

1
ENERGY
PERFORMANCE

2
NETWORK
QUALITY

3
MEASUREMENT AND
INSTRUMENTATION



SYNCHRO COUPLER Range

Synchronization instruments for LV networks

Synchronization instruments

Measurement and instrumentation

PRODUCT ADVANTAGES

- + INTEGRATED IN A 96 X 96 FORMAT
- + 1 synchronization command
- + 1 control command
- + 3 command modes for synchronization
- + Adjustment in just a few seconds (PID model)

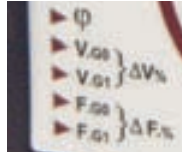

Display of deviations between setpoint and measurement



LED display of 3 measurements: phase, frequency and voltage



User-programmable

Description

The **SYNCHRO COUPLER** is an automatic synchronization instrument for generator sets. It includes:

- a control relay for assisted manual coupling or automatic coupling with time delay control
- two control relays (fast/slow) for speed adjustment
- an external control loop for opening the coupling relay
- four front panel keys for programming, display and messages (password option included)

SYNCHRO COUPLER



Display:

- phase angle variations by 30 LEDs arranged in a circle
- voltages, frequencies, variations (in%) on 4 digits
- frequency variations \pm , status of coupler relay, conditions obtained in phase, frequency and voltage

Power Supply	Reference
24 VDC	LS9N 421X
48 VDC	LS9N 422X
110 VAC	LS9N 423X
230 VAC	LS9N 424X
400 VAC	LS9N 425X

SYNCHRO COUPLER PID



Display: as for synchro coupler

PID adjustment method (Proportional Integral Derivative) for synchronization that is faster and more accurate than with conventional synchronous couplers

- **Proportional:** proportional correction of measurement errors
- **Integral:** guarantees reduction of adjustment error to 0
- **Derivative:** brings greater stability to the system, enabling you to anticipate the inertia of generator sets (e.g. hydroelectric)

Power Supply	Reference
24 VDC	LS9N 441X
48 VDC	LS9N 442X
110 VAC	LS9N 443X
230 VAC	LS9N 444X
400 VAC	LS9N 445X

1

ENERGY PERFORMANCE

2

NETWORK QUALITY

3

MEASUREMENT AND INSTRUMENTATION



SYNCHRO COUPLER Range

Synchronization instruments for LV networks

Measurement and instrumentation Synchronization instruments

► Electrical specifications

Measurements	
Rated voltage range	110 to 600 V
Frequency	35 Hz...80 Hz
Permanent overvoltage	800 V
Consumption	< 500 μ A
Relay output	
With sealed inverter contact	8 A - 250 Vac / 5 A - 30 Vdc
Multi-measurement (accuracy)	
Phase angle deviation	$\pm 0.5^\circ$
Frequency	± 0.01 Hz
Voltage (RMS)	Class 1 ± 2 digits
Auxiliary power supply	
AC voltage	-10% / +15%
Frequency	35 Hz...450 Hz
Consumption	10 VA

► Environment

Operating temperature	-10°C to +65°C
Storage temperature	-40°C to +70°C
Relative humidity	< 90% at 40°C
Protection rating	3
Pollution level	2

► Mechanical specifications

Casing materials	
Casing and flange	Self-extinguishing black ABS
Front panel	Light grey polycarbonate
Protection rating	IP 54 front panel (IP65 optional)
Weight	350 g
Connection	Holder for 2.5 mm wire
Fitting	Mounting on 8 mm front panel

► Standards

Reference standards	
Safety	IEC 61010-1
Dimensions	DIN 43700
EMC	EN 61326-1
ANSI function	Nos. 25 and 90
Resistance to shock	IEC 60068-2-27
Resistance to vibrations	IEC 60068-2-6
Environment	IEC 60068-1

► Electrical connections

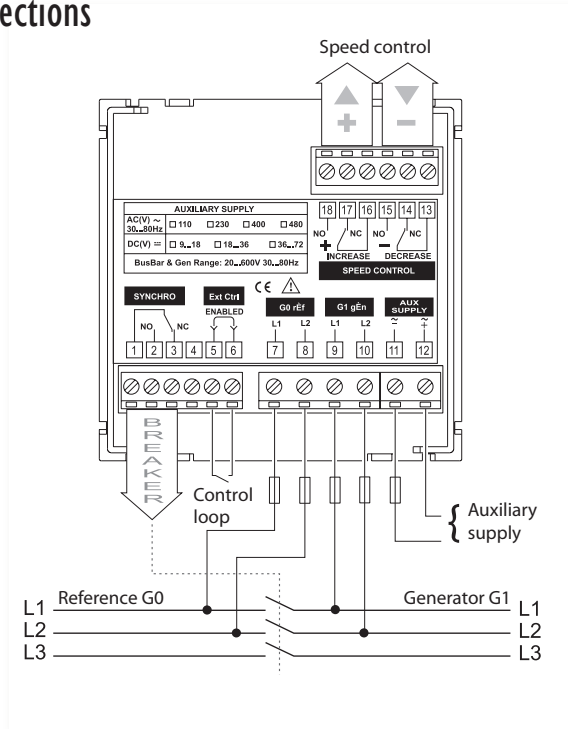

► Dimensions and drilling specifications (mm)

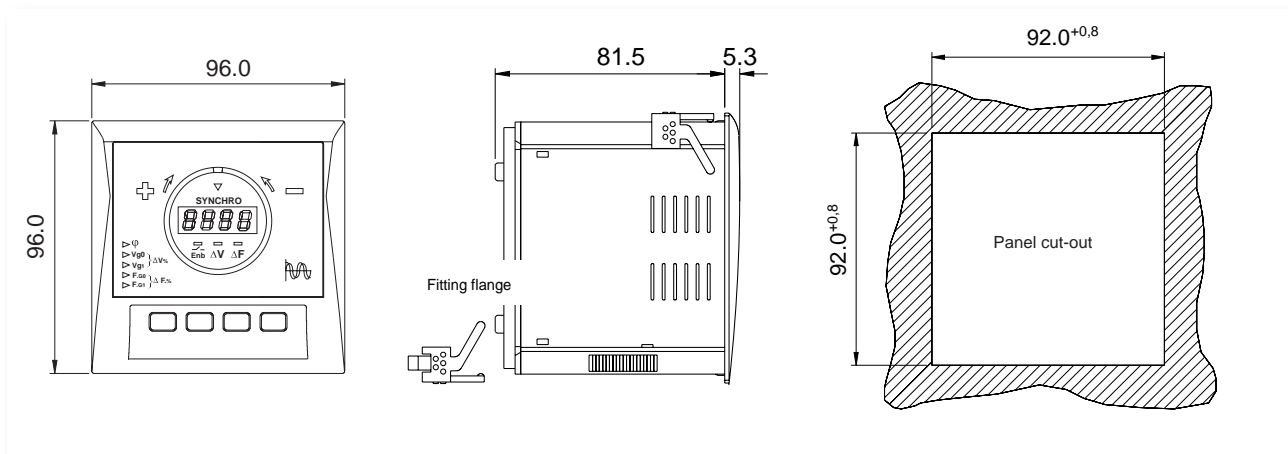

1

ENERGY
PERFORMANCE

2

NETWORK
QUALITY

3

MEASUREMENT AND
INSTRUMENTATION



Notes

Notes
▲ Measurement and instrumentation

A large rectangular area with a light gray background and a pattern of small circles. It contains horizontal lines for writing notes.