

# Installation and User Guide

ALPHA units have been designed to charge any current type of batteries. Thanks to their simple interface, they provide all necessary settings as well as simple operation monitoring. Incorporating protections and basic functions, they are easy and quick to set up. They guarantee a reliable operation and good care of the batteries that will extend their life even when used in harsh conditions. It is also possible to set ALPHA unit as a power supply. Optional supervision printed circuit boards convert ALPHA units in smart systems dedicated to your applications. They feature complex functionalities that are nevertheless easy to use thanks to a user friendly man-machine interface.

## 1 INSTALLATION AND CONNECTION

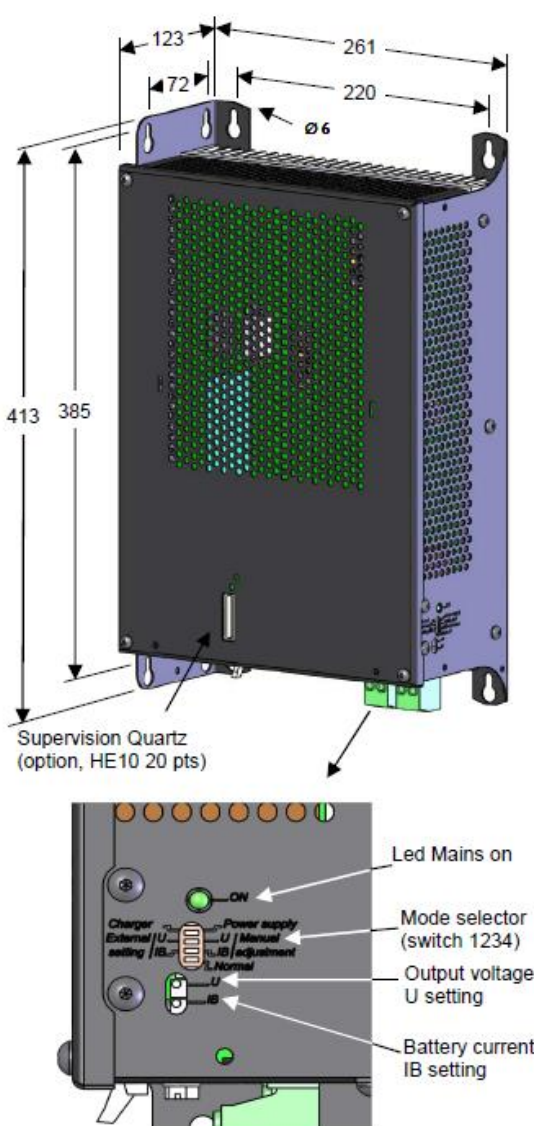

**⚠ Respect product orientation**

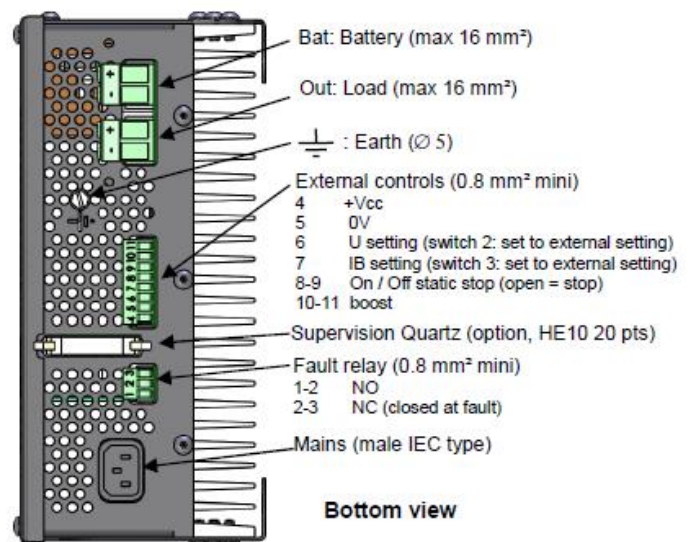
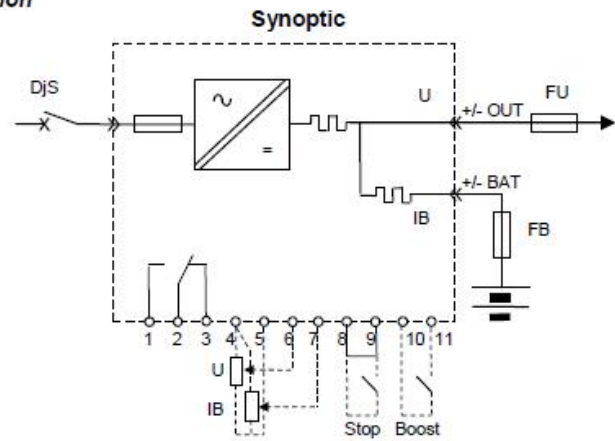

## 2 MISE EN SERVICE

### Battery charger mode

ALPHA is delivered in battery charger mode as a factory setting. Output voltage is predefined for VLRA batteries at 2.27 V per cell, or 13.6 V, 27.2 V, 54.5 V or 136.2 Vdc according to the model. When the desired output voltage is different, i.e. when using a nickel-cadmium battery with 1.42 V per cell as a recommended float voltage, it is possible to adjust output voltage by roughly  $\pm 5\%$  using U potentiometer.

ALPHA 120V model (for a 60 lead acid cell battery) and 240V model (for a 120 lead acid cell battery) can be set to 110V (for a 54 lead acid cell battery) and 220V (for a 108 lead acid cell battery) by setting switch 4 of mode selector in the opposite position (opposite to “normal”). modules ALPHA 120V (60 éléments plomb) et 240V (120 éléments plomb) peuvent être configurés en 110V (54 éléments plomb) et 220V (108 éléments plomb) en basculant le switch 4 du sélecteur de mode dans la position opposée à «Normal».

### Power Supply mode

To use ALPHA as a power supply, set switch 1 of mode selector in the “Power Supply” position. Factory setting is then 12, 24, 48, 120 or 240 Vdc according to the model. Output voltage can be adjusted by roughly  $\pm 5\%$  using U potentiometer.

## CAUTION !

Please respect mounting position: vertical position, connectors facing down (side mounting is possible). Verify that vents are not obstructed. 50 mm required above and below unit.

Verify that nominal voltage corresponds to the application.

Make sure that battery and load are connected to their respective connector.

Verify positive and negative polarity on battery and load.

Verify that metallic assembly is connected to the earth.

## 3 ADVANCED FUNCTIONS

### Battery current setting

ALPHA charger possesses two current regulations. This allows to set the charging current of the battery. To limit the charging current to the correct value (recommended 10% of the battery capacity C10), use IB potentiometer. Factory setting corresponds to 10% of the nominal current of the charger. One turn of IB potentiometer equals 5% of the nominal current of the charger. When turning clockwise, current increases up to nominal current. Note that this affects only the battery output.

### Boost function

To faster charge the batteries, it is useful to set the voltage at a higher level for several hours. ALPHA Charger features a BOOST function that raise the charging voltage by 3.8%. This function is activated by strapping terminals 10 and 11. Cable shall not to exceed 2 meters. Releasing the strap resumes normal operation.

### Static stop command

It is possible to force ALPHA to stop using an external command. Remove factory installed strap between terminals 8 and 9 (On/Off static stop) and insert a switch or a dry contact. Unit is stopped when contact is open.

### Output voltage U setting using external potentiometer

It is possible to set output voltage U from 0 to 125% of ALPHA nominal voltage using an external pot. Before powering the unit, connect the potentiometer (only use VERTIV Potentiometer kit code 6002928) as shown in schema. Set switch 2 in position « External setting ». Resume power.

### Current IB setting using external potentiometer

It is possible to set current IB on battery output from 0 to 100% of ALPHA nominal current using an external pot. Before powering the unit, connect the potentiometer (only use VERTIV Potentiometer kit code 6002928) as shown in schema. Set switch 3 in position « External setting ». Resume power.

### Protections

ALPHA contains internal devices to protect itself and to protect the connected load:

Protection against reverse polarity (warning, it is mandatory to respect FB and FU fuse ratings, see table)

Protection against overload and short-circuit by output current limitation.

Protection against fire in case of internal fault by internal input fuse.

Protection against output overvoltage: secure the load in case of regulation loss by stopping the unit.

Overvoltage set to 105% of nominal voltage for more than 2 seconds.

Thermal protection against abnormal temperature and heat dissipation.

These two last defaults are reported on the fault relay (dry contact NO + NC terminals 1-2-3, signals a fault in normal position). To reset, remove power for at least 30 seconds.

## CAUTION !

To avoid any control perturbation, it is recommended:

- not to exceed 2 meters for cabling the auxiliaries
- not to bring auxiliaries cables outside charger cabinet
- to separate auxiliaries cables and power cables
- to twist auxiliaries cables serving the same function

## 4 OPTIONS

### Supervision Kit Quartz

Supervision kit Quartz (ref. 6 007 981) can be associated to ALPHA charger. This kit includes a supervision PCB, a display with two lines of eight characters and a I/O PCB for six inputs and 5 outputs. Quartz supervisor offers a wide range of parameters for an advanced automatic battery charger. Displays of voltage, current, alarms, faults of both output and battery grant the user management of the complete system.

### Potentiometer kit for analogue control

This kit contains a ten-turn potentiometer (ref. 6002928). It allows a fine analogue setting of the output voltage U or the current of battery branch IB.

## 5 TROUBLE SHOOTING

### No output voltage and mains present LED off

Make sure power is present at ALPHA input and DJS is closed.

### No output voltage and mains present LED on

Make sure there is a strap between 8 and 9 terminals, or static stop command is closed if wired.

Verify if fault relay signals a fault. In this case, remove power for at least 30 seconds. Make sure vents are not obstructed, and ambient temp is not too high. Power on again.





### Output voltage is not the one desired

Make sure you are using the right model (see name plate). Verify position of the mode selector switches (see § technical data). If you are at less than 5% of the desired voltage, adjust again the output voltage using potentiometer U.

If the problem remains, call maintenance services at +33 (0)4 72 47 63 77 or [infrastructure@chloride.com](mailto:infrastructure@chloride.com)

## 6 SPECIFICATIONS

### Programming of the output voltage mode

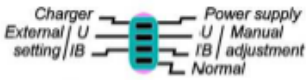
Position of Mode selector	Used as → model ↓	Charger		Power supply		External setting
						
	12 V	13.6 Vdc	N/A	12.0 Vdc	N/A	0 to 15 Vdc
	24 V	27.2 Vdc	N/A	24.0 Vdc	N/A	0 to 30 Vdc
	48 V	54.5 Vdc	N/A	48.0 Vdc	N/A	0 to 60 Vdc
	120/110 V	136.2 Vdc	122.6 Vdc	120.0 Vdc	110.0 Vdc	0 to 150 Vdc
	240/220 V	272.4 Vdc	245.2 Vdc	240.0 Vdc	220.0 Vdc	0 to 300 Vdc

**Note :** Charger of Power Supply, values in this table are factory settings. Potentiometer U allows adjusting output voltage by roughly ±5%. When terminals 10 and 11 are strapped, output voltage raises by 3.8% (Boost function).

Specifications		12 V	24 V	48 V	120 / 110 V	240 / 220
		6 008 584	6 008 585	6 008 586	6 008 587	6 008 588
<b>INPUT</b>	Voltage	208, 220, 230, 240 Vac (187Vac à 264Vac)				
	Frequency	50/60Hz (47Hz à 63Hz)				
	Power	2000VA				
	Recommended protection : C Breaker curve C	16 A				
	Power factor (PFC)	> 0.95				
	Inrush current	< 6 In				
<b>BATTERY</b>	Recommended protection: Fuse type gG	80 A	80 A	40 A	20 A	10 A
	Maximum permanent discharge current	60 A	60 A	30 A	12 A	6 A
	maximum 10 second discharge current	120 A	120 A	60 A	24 A	12 A
	maximum 1 second discharge current	200 A	200 A	100 A	40 A	20 A
<b>OUTPUT</b>	Nominal current	60 A	60 A	30 A	12 A	6 A
	Recommended protection: Fuse type gG	63 A	63 A	32 A	16 A	6 A
	Output current tolerance	0 / +5%				
	Hold up time on mains outage	10ms				
	Output voltage tolerance	± 1%				
	Ripple voltage peak to peak (< 30MHz)	< 500mV	< 500mV	< 500mV	< 1V	< 1V
	Ripple voltage RMS	< 0.1%				
	Overshoot when powering on	< 5%				
	Transient (load / unload)	< 5% / 5ms (from 100% to 10% of nominal current)				
	Fault relay rating	250 Vac / 1A				
<b>VARIOUS</b>	Efficiency (typical)	83%	88%	90%	89%	91%
	Dielectric strength and Isolation resistance	Input / Output	4200Vdc - 1mn			
Input / Ground		2300Vdc - 1mn / > 100MΩ				
Output / Ground		2000Vdc - 1mn / > 100MΩ				
	Weight	9,8 kg				
	Protection	IP 20				
	Operating temperature / storage temperature	0°C to +50°C / -45°C to +85°C				
	Cooling	Natural convection				
	Altitude	0 - 1000m				
	Relative humidity	< 95% à 20°C				
<b>STANDARDS</b>	Charger / Power Supply	NF C 58-311 / EN 61204				
	Low voltage directive	NF EN 60950-1 §2.10, §5.2				
		TBTS			-	
	NF EN 55011 et 55022	Class A				
	NF EN 61000- 3-2	Class A				
	CEM NF EN 61000-4-2, 4-3, 4-4, 4-6	Level 3				
	NF EN 61000- 4-5	DC : Level 1			AC : Level 2	
	NF EN 61000- 6-2, 6-4	Industrial				

Chloride.com  
 30 avenue Montgolfier – BP90  
 France  
 Tel: +33 (0)4 72 47 63 77

Notice : 6008595