

High Performance  
**Butterfly Valves**  
Series 7400

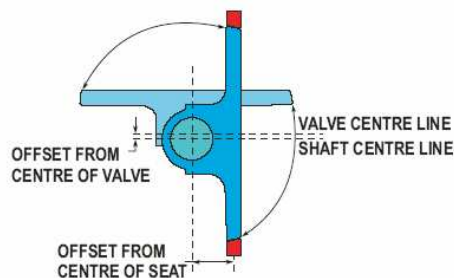

**Aiming at Perfection**

## Design Construction



### Double Offset

High Performance Butterfly Valves are available in Wafer and Lug type designs conforming to API 609 standard. The Disc construction is Double Offset providing excellent controllability, bubble tight shut off, greater seat life and smooth operation. Valves are specially designed for applications in Chemical, Petroleum, Hydro Carbons Processing, Pulp & Paper and HVAC industries.

Well supported shaft with heavy duty bearings ensure perfect alignment of seat and disc for smooth and trouble free operations. Valves have been rigorously tested to ensure industry performance requirements.

## Features

- ▶ Valve body is solid, heavy duty. Seat Retainer construction allows Gasket conforming to API 609.
- ▶ Optimal disc geometry and cavity free flow passage offers minimum flow resistance and high Cv values.
- ▶ Heavy duty pins connecting valve shaft to disc avoids lost motion under high torque conditions.
- ▶ Long life, easy field replaceable seat placed in body, away from flow steam, provides bubble tight shut off. Valves are equally suitable for control and tight shut off applications.
- ▶ Low friction bearings provide maximum radial support for higher shaft loads. The PTFE lined bearings having low co-efficient of friction minimizes operating torque and reduces actuator size. They are slip in-place type, easy for assembly and disassembly.
- ▶ Seat option includes PTFE, EPDM, Viton Soft Seats and Flexible Metal Seats to suit variety of fluids and applications.
- ▶ Recommended for critical applications including high temperature services, throttling steam control, liquor services, gas applications, vacuum applications, corrosive fluids, refinery services, chemical services, hydrocarbon services, etc.

## Specifications

<b>Valve Sizes</b>	:	2" (50mm) to 80" (2032mm)
<b>Ratings</b>	:	Class 150 , Class 300 ,Equivalent to DIN
<b>Body Style</b>	:	Wafer , Lug (Single Flange)
<b>Design Standard</b>	:	API 609 , ANSI B 16.34 , ANSI B 16.5
<b>Testing Standard</b>	:	API 598 , FCI 70-2
<b>Seat Leakage Option</b>	:	Class VI for PTFE, EPDM, Viton Soft Seats, Class IV for Flexible Metal Seats
<b>Flow Direction</b>	:	Bi Directional

## Conformity To Codes

<b>Design &amp; Manufacturing</b>	:	API 609 Category B BS 5155 API 607 (Fire Safe)
<b>Face to Face Dimensions</b>	:	API 609 BS 5155 BS EN 558-1 ISO 5752
<b>Flange Dimensions</b>	:	ANSI B 16.5 (DN 50 to DN 600) ANSI B 16.47 (DN 650 to DN 1500)
<b>Pressure Temperature Rating</b>	:	ANSI B 16.34
<b>Valve Inspection</b>	:	API 598 FCI 70-2

## Testing and Inspection

Test	Test Pressures	Test Stds	Test Medium	Acceptance Criteria
<b>Hydro Test</b>	30 Bar (ANSI 150#)	API 598	Water	No Leakage
	80 Bar (ANSI 300#)	API 598	Water	No Leakage
<b>Seat Leakage Test</b>	Max $\Delta P$ Shut Off	FCI 70-2	Water	Class VI
	20 Bar (ANSI 150#)	API 598	Water	No Leakage
	54 Bar (ANSI 300#)	API 598	Water	No leakage

## Seat Design Options

a wide variety of seat design options which are cost-effective and provide solutions to your service requirements. The Double Offset disc construction minimizes the interference between seat & disc edges allowing longer seat life even under frequent valve operations. Seats are available in both rigid & flexible construction to suit specific requirements. The seats are held rigidly by the seat retainer which is inserted within the body per API 609 design requirements. This construction allows use of Gasket conforming to API 601 (ANSI 16.5) Standard and eliminate the possibility of JOINT LEAKAGE from body to the atmosphere.

Virgin PTFE seat having a flexi lip provides bubble tight shut off in both the directions. Suits to wide range of applications. Maximum working Temperature 200°C.

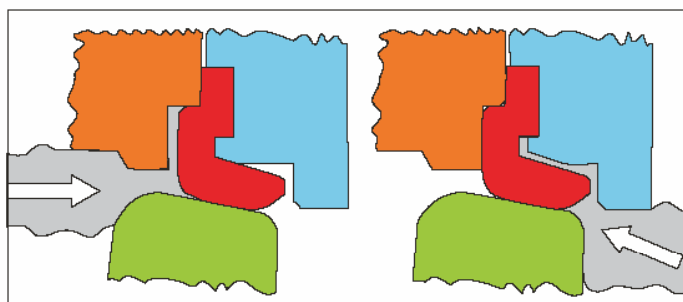

[Flexible PTFE Seat](#)

Rubber seats are available in EPDM, NBR and Viton materials. Rigid seats allow a clean flow passage & prevents fluid deposition within the seat. These seats are ideal for many applications in Sugar Industry Rigid seats allows unidirectional flow (i.e. shaft side inlet) providing tight shut off under positive & vacuum applications. With this configuration the shaft side is upstream side.

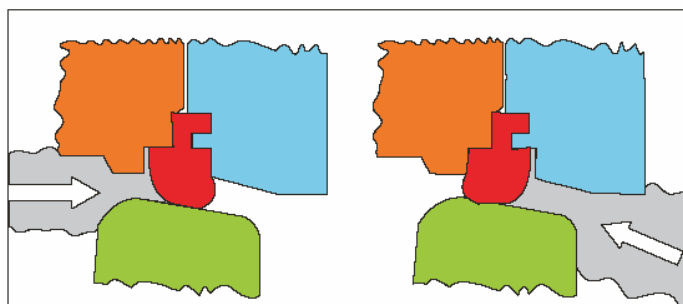

[Flexible Rubber \(EPDM / NBR / Viton\) Seat](#)

Most suitable for high consistency fluids having suspended hard particles, for erosive services, for high temperature services >200° to 550°C.

Die pressed stainless steel seats with inbuilt flexible property gives Class IV leakage with minimal torque requirements

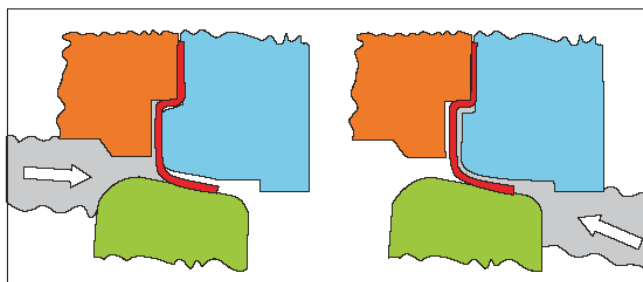

Flexible Metal

**Flow from Seat Retainer Side** The lip shaped PTFE Seat moves axially in the direction of flow with the assistance of line pressure. The tightness between seat and disc increases with increases in line pressure.

**Flow from Shaft Side** With the line pressure acting on the disc, it tries to move towards the seat which is supported by Seat Retainer. Seat does not move giving simple leak tight seal.



Fire Safe Design

## Material Of Construction

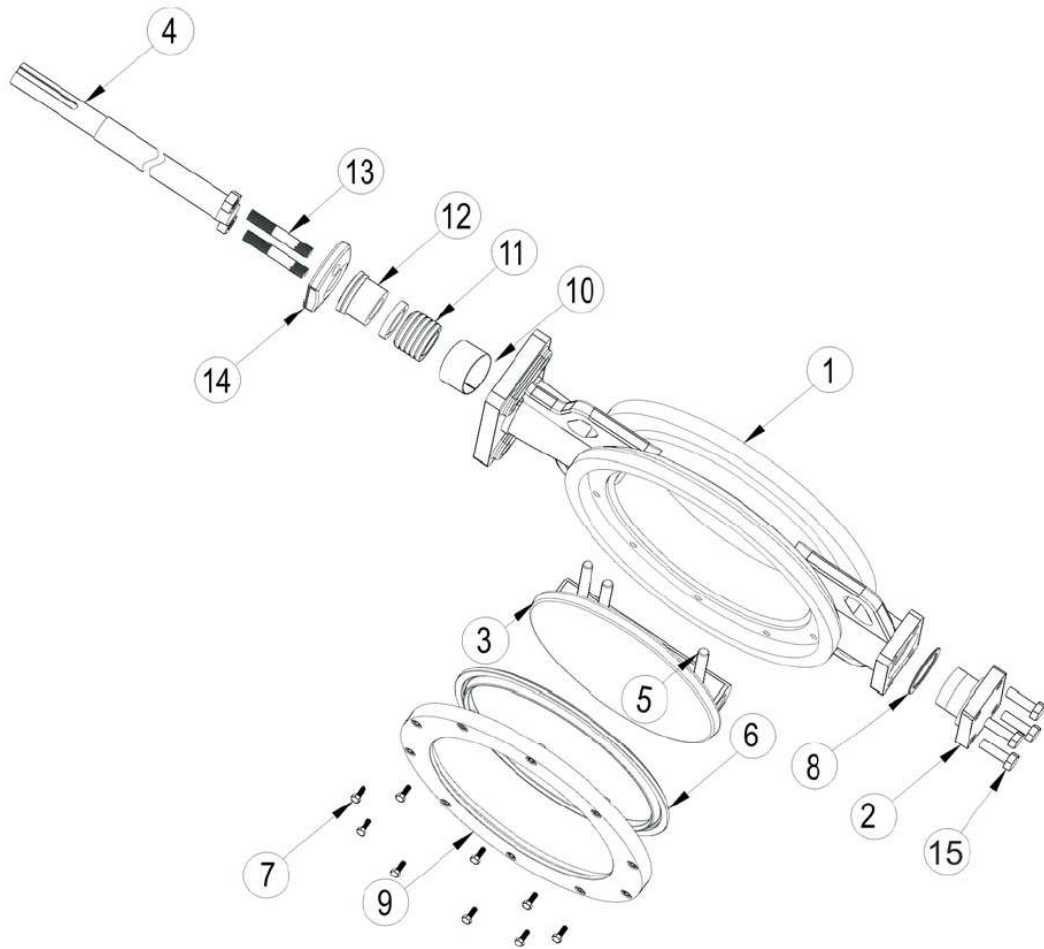

Sr. No.	Part Name
1	Valve Body
2	End Cover
3	Disc
4	Valve Shaft
5	Disc
6	Seat Ring
7	Seat Retainer Screw

Sr. No.	Part Name
8	Body Gasket
9	Seat Retainer
10	Guide Bush
11	Gland Packing
12	Gland Bush
13	Gland Studsr
14	Gland Flange
15	End cover bolts

## Gland Packing Options

Single and Double set of V-Teflon rings (up to 200°C) and Graphite Moulded rings (>200°C up to 600°C) as standard. Inverted V-ferred for vacuum application with upper set of V-Rings positioned Teflon packings are of reverse direction. Low fugitive Emission packings are provided on The LFE packing arrangement request. comprises of live loaded packings. The packing gland is loaded with spring washers to maintain a continuous compressive lead to gland packings as shown in figure below

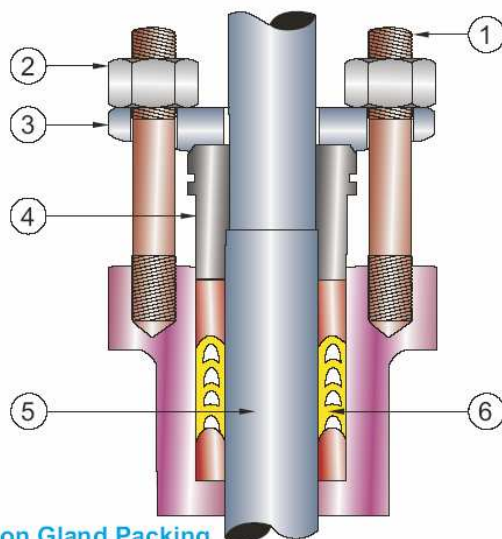

**Single V-teflon Gland Packing**

Sr. No.	Part Name
1	GLAND STUD
2	NUT
3	GLAND FLANGE
4	GLAND BUSH
5	VALVE SHAFT
6	V-RING TEFLON GLAND PACKING
7	V-RING TEFLON GLAND PACKING

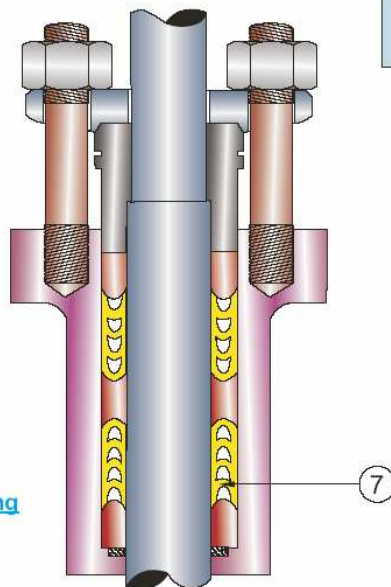

**Inverted V-teflon Gland Packing  
For Vacuum Application**

## Gland Packing Options

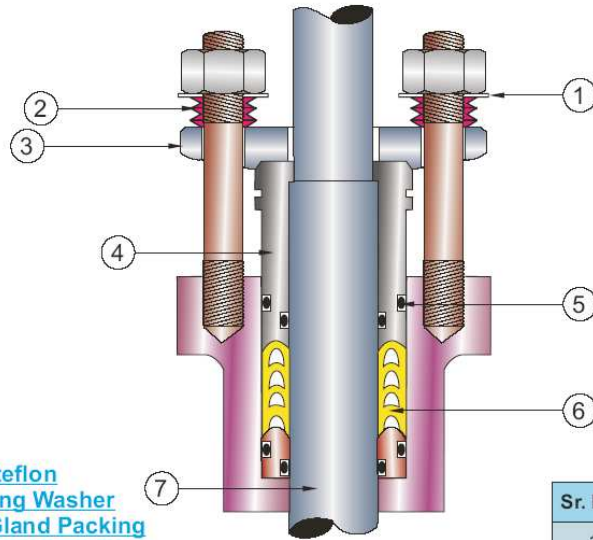

Single V-teflon  
With Spring Washer  
Loaded Gland Packing

Sr. No.	Part Name
1	WASHER
2	SPRING WASHER
3	GLAND FLANGE
4	GLAND BUSH
5	'O'RING
6	V-RING TEFLON GLAND PACKING
7	VALVE SHAFT
8	GRAFOIL GLAND PACKING

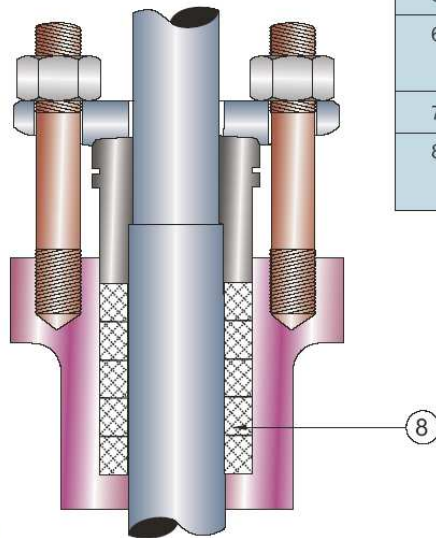

Single Grafoil Packing

## Valve Torques (N m)

ANSI Class 150

$\Delta P$ , Bar

VALVE SIZE		SOFT SEATED VALVE				FIRE SAFE DESIGNED VALVE				METAL SEATED VALVE			
INCH	MM	$\Delta P = 5$	$\Delta P = 10$	$\Delta P = 15$	$\Delta P = 20$	$\Delta P = 5$	$\Delta P = 10$	$\Delta P = 15$	$\Delta P = 20$	$\Delta P = 5$	$\Delta P = 10$	$\Delta P = 15$	$\Delta P = 20$
2"	50	32	40	46	49	51	55	59	65	53	65	69	72
2.5"	65	36	39	48	53	52	54	62	72	60	72	78	89
3"	80	38	40	49	55	58	65	72	79	72	81	89	97
4"	100	42	46	54	65	72	82	90	98	82	92	112	127
5"	125	52	62	68	89	78	95	109	168	98	112	129	190
6"	150	64	94	148	164	112	145	178	190	124	160	197	230
8"	200	105	149	168	199	285	320	360	390	308	325	402	422
10"	250	190	230	270	350	290	328	392	410	318	336	408	428
12"	300	240	290	380	440	298	375	460	582	336	433	531	635
14"	350	420	490	620	732	558	740	950	1040	598	784	971	1158
16"	400	510	790	890	1400	942	1062	1340	1730	948	1089	1386	1780
18"	450	780	975	1680	1920	980	1318	1862	2100	1046	1345	1944	2180
20"	500	970	1480	1980	2300	1240	1724	2100	2640	1366	1793	2305	2818
22"	550	1312	1970	2550	3400	1620	2240	2700	3890	1628	2320	2896	3990
24"	600	1840	2400	2950	3940	2350	2850	3450	4300	2500	2930	3780	4400
26"	650	2290	2978	3818	4334	2817	3663	4695	5634	3467	4506	5778	6934
28"	700	2901	3741	4656	5084	3568	4601	5728	7043	4392	5663	7050	8668
30"	750	3208	4200	5268	5778	3945	5165	6479	7700	4853	6356	7974	9477
32"	800	3741	4886	6107	7164	4601	6009	7511	8919	5663	7397	9246	10980
34"	850	4581	5955	7252	8320	5634	7324	8919	11268	6934	9014	10890	13867
36"	900	5343	6870	8697	9592	6573	8451	10329	13146	8091	10402	12712	16180
38"	950	6107	7634	9925	10862	7511	9391	12208	15023	9246	11556	15023	18491
40"	1000	6870	9161	11451	12712	8451	11268	14085	16902	10402	13867	17335	20802
42"	1050	7634	10688	12979	13867								
44"	1100	9161	12213	14124	15023								
46"	1150	10688	12979	15269	17334								
48"	1200	12213	14504	17176	19067								
50"	1250	13507	15973	18791	21234								
52"	1300	15034	17852	21024	23834								
54"	1350	16559	19730	23254	26290								
56"	1400	19379	22784	26895	30046								
58"	1450	22432	25016	29244	34967								
60"	1500	25955	30301	35351	43768								
64"	1600	32063	37113	42984	50558								
66"	1650	35467	41106	47682	55902								
72"	1800	41927	48622	55904	70347								
76"	1900	46714	54174	62288	78381								
80"	2000	51762	60026	69017	86848								
84"	2100	57067	66180	76091	95750								
88"	2200	62631	72633	83511	105087								
92"	2300	68454	79385	91275	114857								
96"	2400	74536	86439	99384	125061								
100"	2500	80879	93793	107838	135701								
104"	2600	87610	101446	116639	146883								
108"	2700	94478	109399	125782	158281								
110"	2750	98010	113489	130484	164198								
112"	2800	101606	117653	125273	170222								
116"	2900	108994	126206	145107	182598								
120"	3000	116640	135061	155288	195408								

## ANSI Class 300 $\Delta P$ , Bar

VALVE SIZE		SOFT SEATED VALVE					FIRE SAFE DESIGNED VALVE					METAL SEATED VALVE							
INCH	MM	$\Delta P=0-10$	$\Delta P=20$	$\Delta P=25$	$\Delta P=35$	$\Delta P=40$	$\Delta P=51$	$\Delta P=0-10$	P=20	$\Delta P=25$	$\Delta P=35$	$\Delta P=40$	$\Delta P=51$	$\Delta P=0-10$	P=20	$\Delta P=25$	$\Delta P=35$	$\Delta P=40$	$\Delta P=51$
2"	50	45	53	61	68	73	82	52	58	64	72	79	89	78	83	85	89	91	93
2.5"	65	48	55	64	75	81	90	65	71	78	86	90	99	81	88	92	96	99	107
3"	80	57	60	71	82	92	98	76	81	88	95	101	109	95	101	104	107	109	120
4"	100	62	68	79	88	99	104	96	107	117	127	140	148	129	145	154	165	180	192
5"	125	78	93	115	124	134	148	123	138	156	166	179	194	167	182	196	208	223	240
6"	150	96	166	178	185	198	220	142	192	212	225	240	262	188	218	246	264	282	304
8"	200	172	202	235	260	295	335	240	302	340	370	406	438	308	402	445	480	517	541
10"	250	218	325	380	398	422	468	362	496	574	614	650	702	505	666	768	829	878	936
12"	300	322	466	525	585	638	712	506	728	953	1073	1189	1377	690	990	1380	1560	1740	2041
14"	350	498	762	985	1205	1285	1405	883	1316	1573	1803	2023	2203	1267	1876	2161	2401	2761	3001
16"	400	836	1485	1612	1790	1940	2110	1261	1919	2307	2636	2952	3157	1686	2352	3001	3481	3963	4203
18"	450	990	1980	2165	2390	2550	2990	1579	2615	3124	3567	3977	4467	2167	3250	4083	4744	5403	5944
20"	500	1520	2450	2775	2980	3236	3650	2193	3476	4245	4892	5496	6044	2865	4501	5715	6804	7756	8437
22"	550	2040	3520	3890	4118	4288	4702	2828	4522	5347	6278	6907	7795	2615	5524	6804	8437	9526	10887
24"	600	2515	4074	4488	4915	5315	5780	3440	5312	6326	7357	8169	9014	4365	6549	8164	9798	11023	12247
28"	700	3820	5154	5689	6716	7315	8160	5253	7693	9052	11544	11843	13293	6686	10231	12414	16371	16371	18426
30"	750	4315	5886	6645	7758	8357	9212	5909	8537	10485	12747	14073	15183	7503	11187	14325	17736	19789	21154
32"	800	4946	7288	7459	9278	10160	12225	6839	10124	11574	14524	15994	18054	8731	12960	15688	19770	21828	23883
36"	900	6986	9721	10818	13814	15365	17166	9633	14385	16323	19664	21325	23774	12279	19049	21828	25513	27285	30382
40"	1000	9315	12896	14715	17678	19262	20612	12843	18726	21345	25491	27615	30826	16371	24556	27975	33304	35968	41040
42"	1050	10776	14056	16330	19128	20901	22728	14938	19989	23485	28214	30433	34010	19099	25921	30639	37300	39964	45292
48"	1200	14688	19248	21297	26005	28049	29148	20305	27608	30631	37648	40668	43881	25921	35968	39964	49290	53286	58614

## ANSI Class 600 $\Delta P$ , Bar

VALVE SIZE		SOFT SEATED VALVE					FIRE SAFE DESIGNED VALVE					METAL SEATED VALVE							
INCH	MM	$\Delta P=0-10$	$\Delta P=35$	$\Delta P=55$	$\Delta P=70$	$\Delta P=80$	$\Delta P=102$	$\Delta P=0-10$	$\Delta P=35$	$\Delta P=55$	$\Delta P=70$	$\Delta P=80$	$\Delta P=102$	$\Delta P=0-10$	$\Delta P=35$	$\Delta P=55$	$\Delta P=70$	$\Delta P=80$	$\Delta P=102$
3"	80	58	85	103	121	133	141	85	113	155	181	193	204	102	112	168	192	203	218
4"	100	64	98	148	169	189	212	125	208	265	323	359	390	151	268	342	428	469	508
5"	125	82	128	186	222	249	278	160	272	392	477	563	613	189	356	518	663	798	848
6"	150	102	191	242	306	348	379	205	383	512	613	743	933	258	516	712	840	1048	1388
8"	200	176	265	382	488	556	695	312	536	890	1015	1087	1297	389	728	1288	1422	1508	1780
10"	250	248	398	665	832	1128	1386	458	879	1289	1522	1781	2044	598	1280	1804	2092	2304	2582
12"	300	369	722	1178	1392	1486	1676	855	1362	2008	2396	2660	3010	1242	1922	2708	3280	3704	4204
14"	350	608	1232	1686	2247	2488	2692	1090	2148	2716	3549	4023	4283	1442	2934	3610	4711	5409	5716
16"	400	892	1812	2242	2821	3476	3832	1532	2891	3737	4546	5347	6030	2042	3840	5102	6122	7099	8088
18"	450	1078	2422	3118	3582	3980	4432	1746	3330	4680	5836	6555	7234	2285	4108	6102	7940	8980	9876
20"	500	1680	3152	3728	4540	5108	5498	2734	4726	3686	8011	10048	10905	3688	6140	8884	11312	14828	16142
22"	550	2132	4186	4760	5986	6435	6986	3545	6399	8735	11323	12629	13700	4778	8442	12540	16481	18623	20224
24"	600	2215	5230	5886	6880	10093	10192	4798	7784	11385	13490	15990	16854	7082	11182	16585	19801	21587	23316

## Cv Values (usgpm)

### ANSI 150#

VALVE SIZE		150#	
INCH	MM	60°	90°
2	50	25	50
2½	65	39	78
3	80	82.5	165
4	100	200	400
5	125	325	650
6	150	525	1050
8	200	1100	2200
10	250	1650	3300
12	300	2550	5100
14	350	2900	5800
16	400	4000	8000
18	450	5250	10500
20	500	7000	14000
24	600	10800	21600
28	700	14935	29870
30	750	17000	34000
32	800	20585	41170
36	900	27750	55500
40	1000	36800	73600
42	1050	41325	82650
44	1100	45600	91200
48	1200	54150	108300
52	1300	60840	121680
54	1350	66750	133500
56	1400	71000	142000
60	1500	79500	159000
64	1600	92160	184320
66	1650	98010	196020
72	1800	116640	233280

### ANSI 300#

VALVE SIZE		300#	
INCH	MM	60°	90°
2	50	25	50
2½	65	39	78
3	80	82.5	165
4	100	200	400
5	125	325	650
6	150	525	1050
8	200	900	1800
10	250	1575	3150
12	300	2375	4750
14	350	2600	5200
16	400	3450	6900
18	450	4650	9300
20	500	5650	11300
24	600	9250	18500
28	700	12785	25570
30	750	14550	29100
32	800	17620	35235
36	900	23750	47500

## Pressure-Temperature Ratings

- A 351 Gr. CF8M , CAST STAINLESS STEEL
- A 216 Gr. WCB , CAST CARBON STEEL
- PTFE
- EPDM
- VITON
- SATURATED STEAM

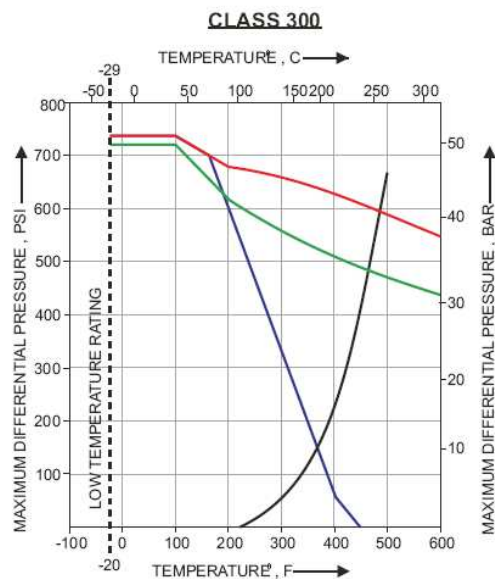
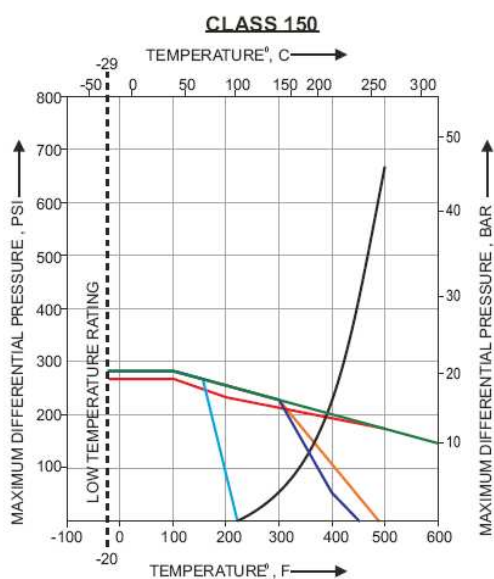

## Flow Characteristic Curves

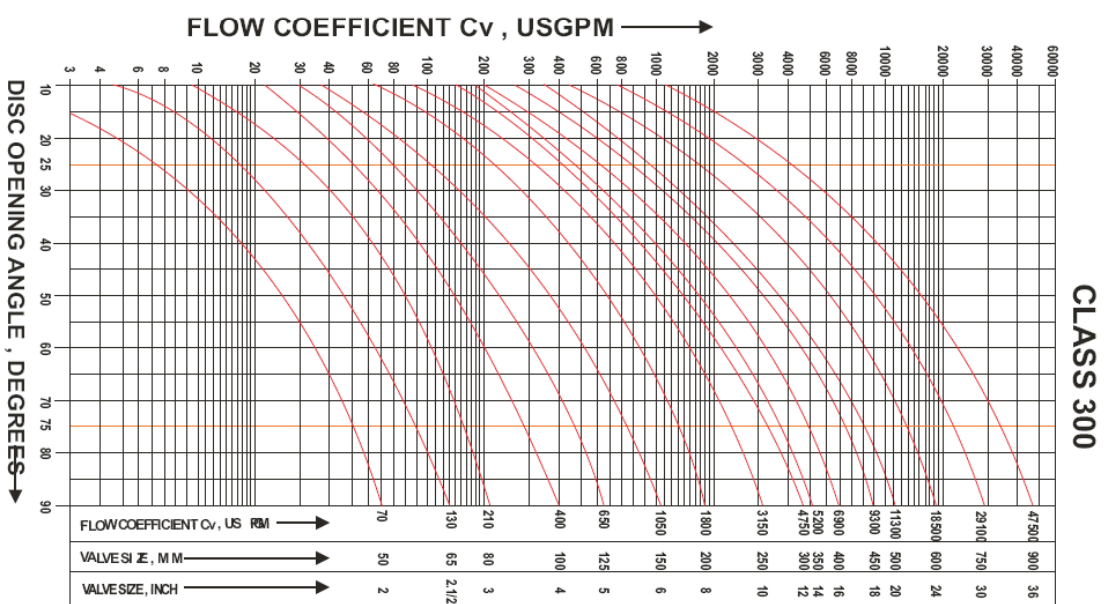
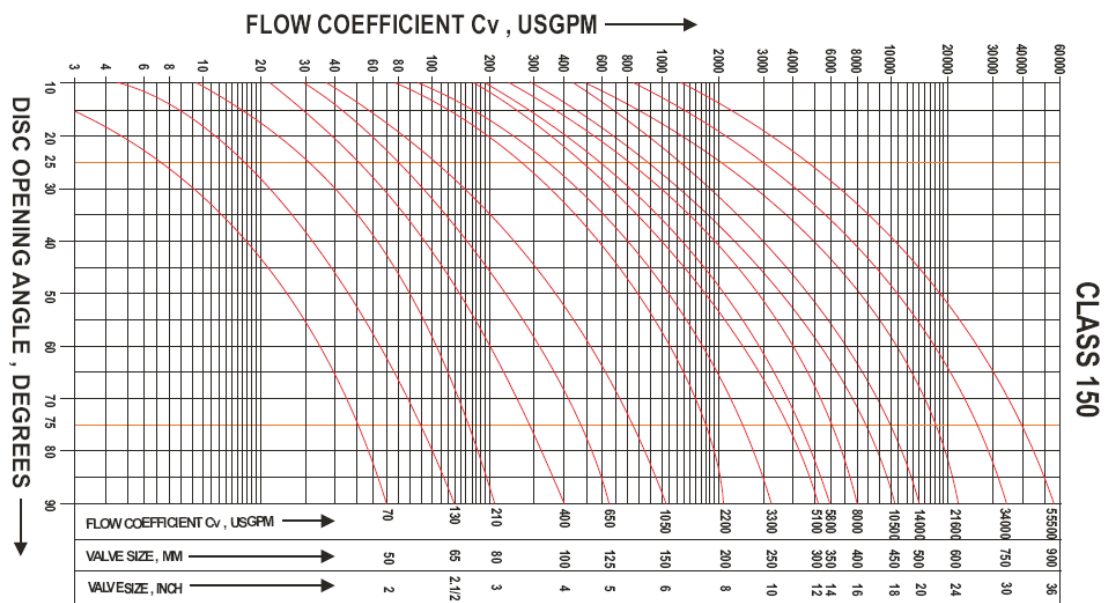

## Actuators

### Piston Actuator (single / Double Acting)

Series 'E' and Series 'P' actuators are powerful, compact and durable units for use on quarter turn applications. These are available in Double acting and spring return versions. Various models are available to suit a large range of torque requirements. All actuators have mounting flanges and drives to ISO 5211.



### Diaphragm Actuator

Series 'Ldp' actuators are Diaphragm operated rotary actuators using linkage arrangement for motion transfer from linear to rotary. These actuators are exclusively designed for Butterfly Valves and are suitable for regulating and on-off applications. The actuators provide accurate, safe and reliable valve operation at low supply pressures. Heavy-duty lever arrangement offers great stability under high torque and shock conditions. Low friction operation allows more accurate control, low maintenance and long service life.



### Hand Lever

Series 'H' Hand lever arrangement provides latching system in open, closed and eight intermediate positions. A pointer indicates the position of disc and an additional lock facility is provided to prevent unauthorized valve operation. Lever actuators are provided on size 2" (50mm) to 6" (150mm) only. For size 8" (200mm) and above, Gear Operators are recommended.



### Gear Operator

Series 'MOR' Gear operators offer simple and reliable manual positioning of the valves. These actuators consist of worm gear arrangement housed in a robust cast iron housing. Sturdy design provides long life and maintenance free services. The high gear ratios enable the minimum input efforts for high torque conditions.



## Accessories Options

Following Accessories are offered  
as per Customers requirements :

- ▶ Pneumatic Valve Positioners,
- ▶ Electro Pneumatic Valve Positioners,
- ▶ Air Filter Regulators,
- ▶ Air Lock Relays,
- ▶ Air Volume Boosters,
- ▶ Limit Switches,
- ▶ Proximity Switches,
- ▶ Solenoid Valves,
- ▶ Position Feedback Transmitters,
- ▶ Quick Exhaust Valves,
- ▶ I/P Converters.



**Limit Switch**



**Smart Positioner**



**Electro Pneumatic Positioner**

## Dimension Wafer Design

\_\_\_\_\_ dia

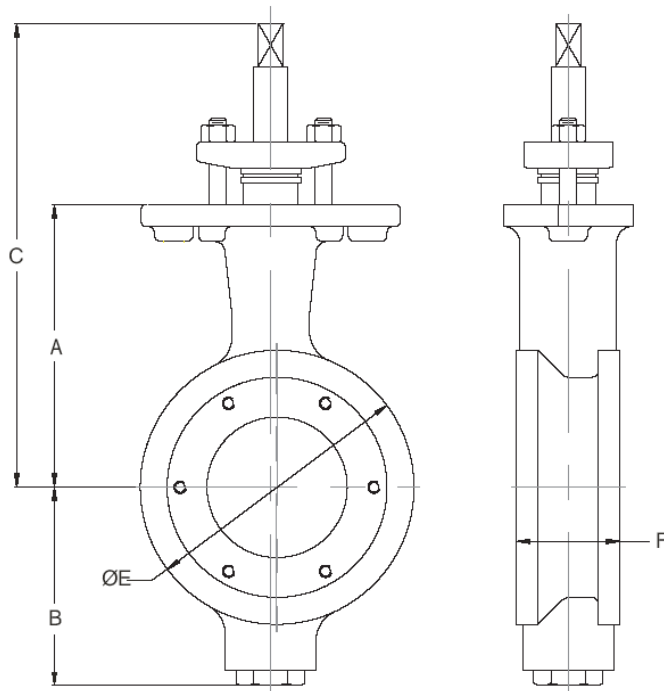

### 150#

VALVE SIZE		150#-WAFER DESIGN				
INCH	(DN)	A	B	C	ØE	F
2"	(50.0)	100.0	75.0	172.0	92.0	43.0
2.1/2"	(65.0)	110.0	80.0	182.0	105.0	46.0
3"	(80.0)	131.0	97.0	221.0	127.0	48.0
4"	(100.0)	153.0	122.0	243.0	157.0	54.0
5"	(125.0)	187.0	155.0	275.0	186.0	57.0
6"	(150.0)	187.0	155.0	277.0	216.0	57.0

### 300#

VALVE SIZE		300#-WAFER DESIGN				
INCH	(DN)	A	B	C	ØE	F
2"	(50.0)	100.0	75.0	172.0	92.0	43.0
2.1/2"	(65.0)	110.0	80.0	182.0	105.0	46.0
3"	(80.0)	131.0	97.0	221.0	127.0	48.0
4"	(100.0)	160.0	142.0	250.0	162.0	54.0
5"	(125.0)	187.0	155.0	257.0	186.0	59.0
6"	(150.0)	187.0	167.0	278.0	216.0	59.0

**Dimension Wafer Design**

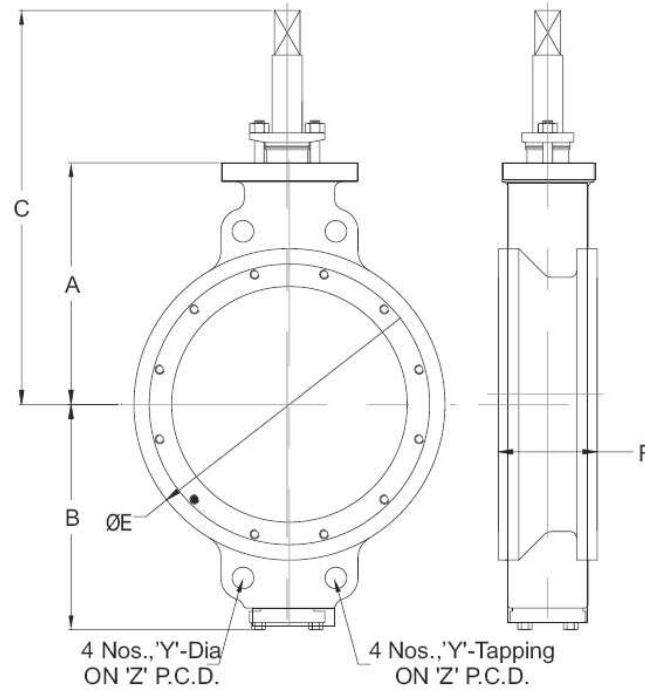

**150#**

VALVE SIZE	150#-WAFER DESIGN								
INCH, (DN)	A	B	C	ØE	F	ØY Hole	Y Tapping	Z	
8" (200.0)	217.0	210.0	318.0	270.0	64.0	22.2	-	298	
10" (250.0)	250.0	240.0	352.0	324.0	71.0	25.4	-	362	
12" (300.0)	310.0	285.0	425.0	381.0	81.0	25.4	-	432	
14" (350.0)	320.0	300.0	438.0	413.0	92.0	28.6	-	476	
16" (400.0)	340.0	350.0	458.0	470.0	102.0	28.6	-	540	
18" (450.0)	375.0	385.0	503.0	535.0	114.0	31.75	-	578	
20" (500.0)	406.0	400.0	551.0	584.0	127.0	-	1.1/8"	635.0	
24" (600.0)	510.0	460.0	660.0	692.0	154.0	-	1.1/4"	749.0	
36" (900.0)	666.0	640.0	893.0	1022.0	241.0	-	1.1/2"	1086.0	

**300#**

VALVE SIZE	300#-WAFER DESIGN							
INCH (DN)	A	B	C	ØE	F	Y	Z	
8" (200.0)	217.0	225.0	318.0	270.0	73.0	7/8"	330.0	
10" (250.0)	270.0	250.0	378.0	324.0	83.0	1"	387.0	
12" (300.0)	310.0	300.0	435.0	381.0	92.0	1.1/8"	451.0	
14" (350.0)	335.0	335.0	490.0	413.0	117.0	1.1/8"	514.0	
16" (400.0)	400.0	402.0	545.0	470.0	133.0	1.1/4"	571.5	
18" (450.0)	425.0	427.0	578.0	533.0	149.0	1.1/4"	629.0	
20" (500.0)	460.0	450.0	700.0	584.0	159.0	1.1/4"	686.0	
24" (600.0)	550.0	564.0	728.0	692.0	181.0	1.1/2"	813.0	
36" (900.0)	742.0	730.0	960.0	1022.0	241.0	1.5/8"	1089.0	

## Dimension Lug Design

\_\_\_\_\_ dia

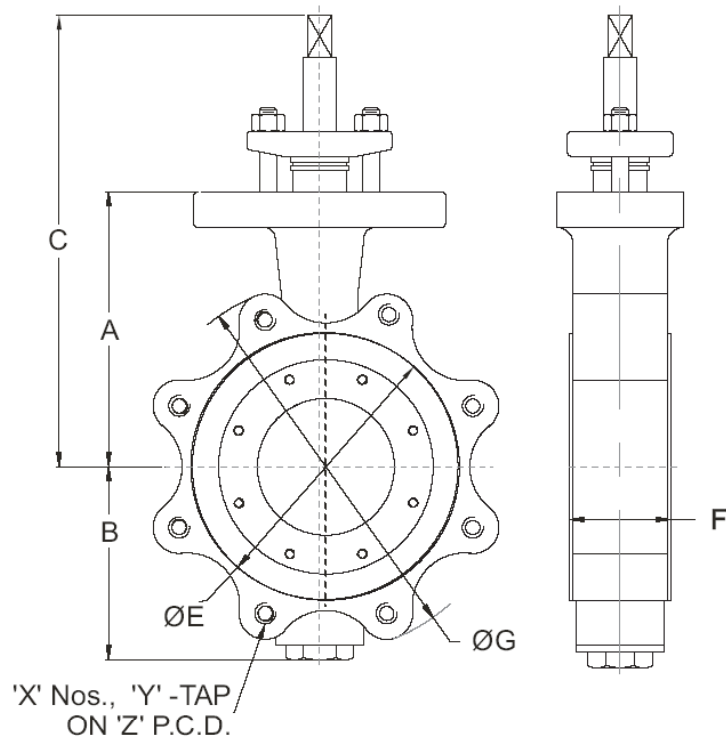

150#

VALVE SIZE		150#-LUGGED DESIGN								
INCH	(DN)	A	B	C	ØE	F	ØG	X	Y	Z
2"	(50.0)	100.0	75.0	172.0	92.0	43.0	152.5	4	5/8"	121.0
2½"	(65.0)	110.0	80.0	182.0	105.0	46.0	178.0	4	5/8"	140.0
3"	(80.0)	131.0	97.0	221.0	127.0	48.0	190.5	4	5/8"	152.0
4"	(100.0)	153.0	122.0	243.0	157.0	54.0	228.5	8	5/8"	190.5
5"	(125.0)	187.0	155.0	275.0	186.0	57.0	254.0	8	3/4"	216.0
6"	(150.0)	187.0	155.0	277.0	216.0	57.0	279.5	8	3/4"	241.0

300#

VALVE SIZE		300#-LUGGED DESIGN								
INCH	(DN)	A	B	C	ØE	F	ØG	X	Y	Z
2"	(50.0)	100.0	75.0	172.0	92.0	43.0	165.1	8	5/8"	127.0
2.1/2"	(65.0)	110.0	80.0	182.0	105.0	46.0	190.5	8	3/4"	149.0
3"	(80.0)	131.0	116.0	221.0	127.0	48.0	209.5	8	3/4"	168.0
4"	(100.0)	160.0	150.0	250.0	157.0	54.0	254.0	8	3/4"	200.0
5"	(125.0)	187.0	147.0	257.0	186.0	59.0	279.4	8	3/4"	235.0
6"	(150.0)	204.0	174.0	278.0	216.0	59.0	317.5	12	3/4"	270.0

## Dimension Lug Design

bla

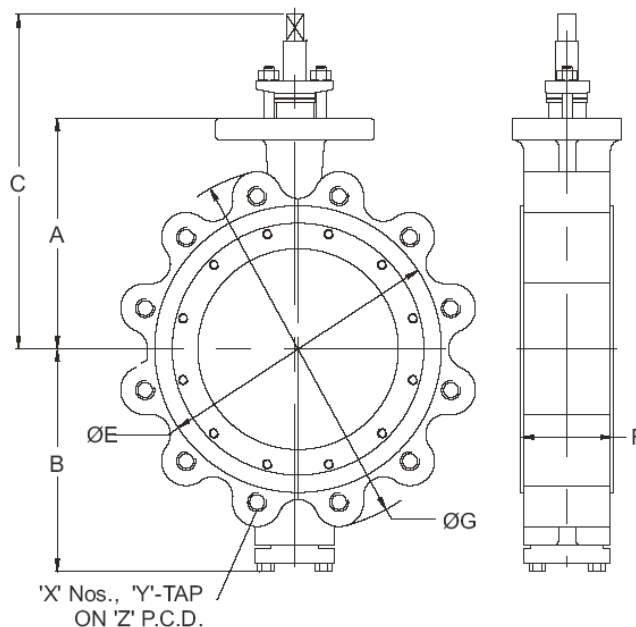

150#

VALVE SIZE	150#-LUGGED DESIGN								
INCH (DN)	A	B	C	ØE	F	ØG	X	Y Tap	Z
8" (200.0)	217.0	210.0	318.0	270.0	64.0	343.0	8	3/4"	298.0
10" (250.0)	250.0	240.0	352.0	324.0	71.0	406.5	12	7/8"	362.0
12" (300.0)	310.0	285.0	425.0	381.0	81.0	482.5	12	7/8"	432.0
14" (350.0)	320.0	300.0	438.0	413.0	92.0	533.5	12	1"	476.0
16" (400.0)	340.0	350.0	458.0	470.0	102.0	597.0	16	1"	540.0
18" (450.0)	375.0	385.0	503.0	535.0	114.0	635.0	16	1.1/8"	578.0
20" (500.0)	406.0	400.0	551.0	584.0	127.0	698.5	20	1.1/8"	635.0
24" (600.0)	510.0	460.0	660.0	692.0	154.0	813.0	20	1.1/4"	749.0
36" (900.0)	666.0	640.0	893.0	1022.0	241.0	1168.0	32	1.1/2"	1086.0

300#

VALVESIZE	300#-LUGGED DESIGN								
INCH (DN)	A	B	C	ØE	F	ØG	X	Y Tap	Z
8" (200.0)	238.0	239.0	343.0	270.0	73.0	381.0	12	7/8"	330.0
10" (250.0)	275.0	278.0	390.0	324.0	83.0	444.5	16	1"	387.0
12" (300.0)	320.0	330.0	435.0	381.0	92.0	520.7	16	1.1/8"	451.0
14" (350.0)	372.0	367.0	490.0	413.0	117.0	584.2	20	1.1/8"	514.0
16" (400.0)	425.0	408.0	545.0	470.0	133.0	647.7	20	1.1/4"	571.5
18" (450.0)	460.0	445.0	578.0	533.0	149.0	711.2	24	1.1/4"	629.0
20" (500.0)	525.0	510.0	700.0	584.0	159.0	774.7	24	1.1/4"	686.0
24" (600.0)	550.0	566.0	728.0	692.0	181.0	914.4	24	1.1/2"	813.0
36" (900.0)	715.0	720.0	960.0	1022.0	286.0	1168.0	32	1.5/8"	1089.0

## Dimension Flanged Design

bla

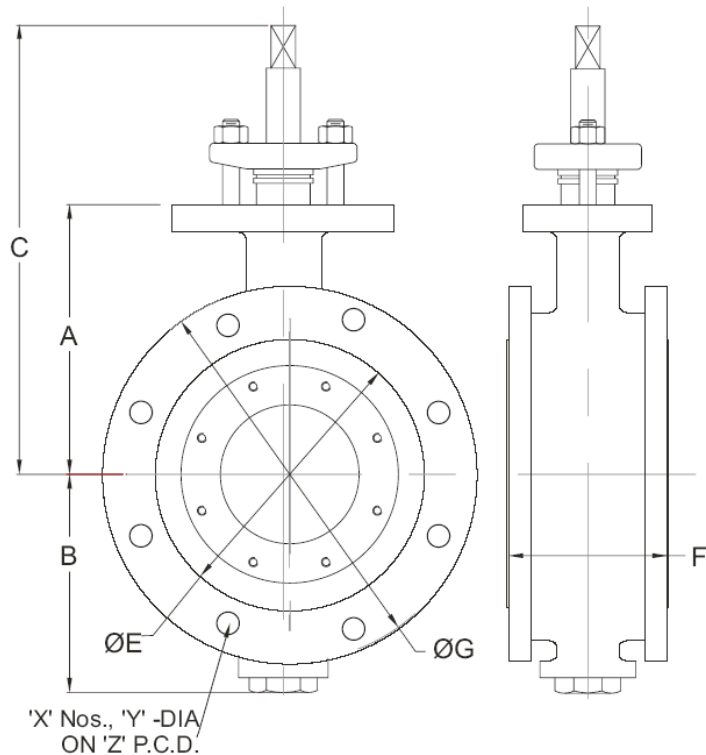

### 150#

VALVE SIZE	150#-FLANGED DESIGN									
INCH (DN)	A	B	C	ØE	F	ØG	X	ØY	Z	
2" (50.0)	100.0	75.0	172.0	92.0	108.0	152.5	4	19.0	121.0	
2.1/2" (65.0)	110.0	75.0	182.0	105.0	112.0	178.0	4	19.0	140.0	
3" (80.0)	131.0	97.0	221.0	127.0	114.0	190.5	4	19.0	152.0	
4" (100.0)	153.0	122.0	243.0	157.0	127.0	228.5	8	19.0	190.5	
5" (125.0)	187.0	155.0	275.0	186.0	140.0	254.0	8	22.0	216.0	
6" (150.0)	187.0	155.0	277.0	216.0	140.0	279.5	8	22.0	241.0	

### 300#

VALVE SIZE	300#-FLANGED DESIGN									
INCH. (DN)	A	B	C	ØE	F	ØG	X	ØY	Z	
2" (50.0)	100.0	70.0	172.0	92.0	150.0	165.1	8	19.0	127.0	
2.1/2" (65.0)	110.0	75.0	182.0	105.0	170.0	190.5	8	22.0	149.0	
3" (80.0)	131.0	92.0	221.0	127.0	180.0	209.5	8	22.0	168.0	
4" (100.0)	172.0	148.0	250.0	157.0	190.0	254.0	8	22.0	200.0	
5" (125.0)	192.0	188.0	257.0	186.0	200.0	279.4	8	22.0	235.0	
6" (150.0)	201.0	190.0	278.0	216.0	210.0	317.5	12	22.0	270.0	

## Dimension Flanged Design

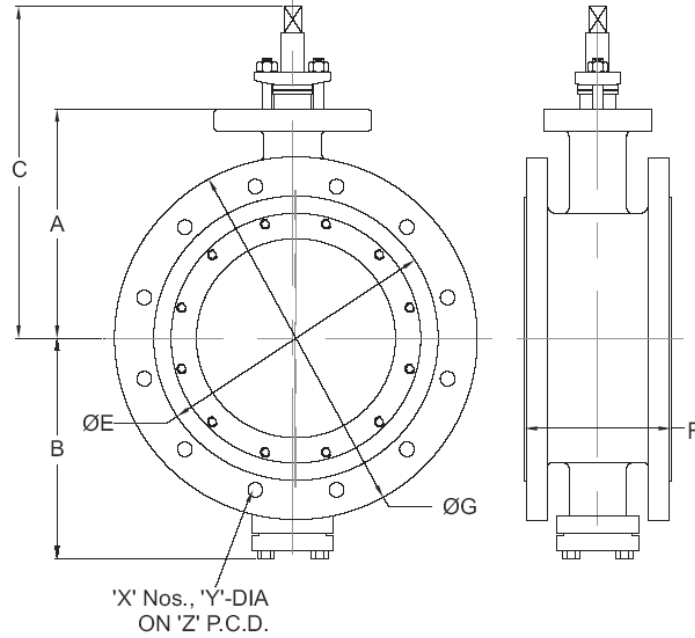

### 150#

VALVE SIZE		150#-FLANGED DESIGN								
INCH	(DN)	A	B	C	ØE	F	ØG	X	ØY	Z
8"	(200.0)	217.0	210.0	318.0	270.0	152.0	343.0	8	22.0	298.0
10"	(250.0)	250.0	240.0	352.0	324.0	165.0	406.5	12	25.0	362.0
12"	(300.0)	310.0	285.0	425.0	381.0	178.0	482.5	12	25.0	432.0
14"	(350.0)	320.0	300.0	438.0	413.0	190.0	533.5	12	28.5	476.0
16"	(400.0)	340.0	350.0	458.0	470.0	216.0	597.0	16	28.5	540.0
18"	(450.0)	375.0	385.0	501.0	535.0	222.0	635.0	16	32.0	578.0
20"	(500.0)	406.0	400.0	551.0	584.0	229.0	698.5	20	32.0	635.0
24"	(600.0)	510.0	460.0	660.0	692.0	267.0	813.0	20	35.0	749.0
36"	(900.0)	666.0	840.0	893.0	1022.0	330.0	1168.0	32	44.4	1086.0

### 300#

VALVE SIZE		300#-FLANGED DESIGN								
INCH.	(DN)	A	B	C	ØE	F	ØG	X	ØY	Z
8"	(200.0)	240.0	220.0	338.0	270.0	230.0	381.0	12	25.4	330.0
10"	(250.0)	263.0	250.0	395.0	324.0	250.0	444.5	16	28.5	387.0
12"	(300.0)	303.0	290.0	445.0	381.0	270.0	520.7	16	32.0	451.0
14"	(350.0)	340.0	320.0	505.0	413.0	290.0	584.2	20	32.0	514.0
16"	(400.0)	400.0	402.0	540.0	470.0	310.0	647.7	20	35.0	571.0
18"	(450.0)	425.0	427.0	620.0	533.0	330.0	711.2	24	35.0	629.0
20"	(500.0)	460.0	450.0	691.0	584.0	350.0	774.7	24	35.0	686.0
24"	(600.0)	523.0	550.0	788.0	692.0	390.0	914.4	24	41.0	813.0
36"	(900.0)	765.0	780.0	950.0	1022.0	510.0	1168.0	32	44.5	1089.0

