

ATC blade fuses



Product description:

The Bussmann™ series ATC fuses are a range of UL® Recognized fast-acting blade fuses for automotive and low-voltage control circuits.

All catalog numbers for these fuses feature the same form, fit and electrical performance characteristics regardless of their housing materials.

Features and benefits:

- Industry standard color coding for quick identification of amp rating.
- Tin-plated zinc terminals for corrosion resistance and enhanced conductivity.
- UL Recognized for use in low voltage control circuits.
- Wide -40°C to +100°C operating temperature range meets the needs of extreme environments.
- Lead free, halogen free and RoHS compliant.
- Test points on specific part/package numbers may speed up circuit troubleshooting.

Catalog symbol

- ATC_

Applications

- Automotive and low-voltage control circuits.

Ratings

Volts: 32 V

Amps: 1-40 A

Interrupting Rating: 1 kA

Agency information

- UL Recognized File E56412, Guide JFHR2, UL 248-1 (1-40 A).
- ISO 8820-3 / SAE® J1284 / JASO 612 (1-40A).
- SAE J1171 (Ignition Protection) see catalog number tables for specific orderable product.
- RoHS compliant

Materials

- Tin-plated zinc terminals
- Tin-plated zinc element
- Housing (see catalog number tables for specific housing materials)
- Housing flammability rating — UL 94

Environmental

- Operating Temperature Range -40°C to 100°C, 95% RH non-condensing.
- Storage Temperature Range -5°C to 35°C or lower, 85% RH non-condensing.



Powering Business Worldwide

Basic catalog numbers*

Basic catalog number (amp)	Color code	Basic catalog number (amp)	Color code
ATC-1	Black	ATC-15	Blue
ATC-2	Gray	ATC-20	Yellow
ATC-3	Violet	ATC-25	Clear
ATC-4	Pink	ATC-30	Green
ATC-5	Tan	ATC-35	Blue/Green
ATC-7½	Brown	ATC-40	Orange
ATC-10	Red		

* See catalog number tables on page four for specific construction, housing material and package availability.

Electrical Characteristics**

% of fuse amp rating	Operating time (sec)	
	Min	Max
110	100 Hrs	—
135	0.75	120 (240***)
160	0.25	50
200	0.15	5
350	0.04	0.5
600	0.02	0.1

** At 23°C for all available catalog numbers., Fuse derating with change in ambient temperature = -0.15% / 1°C

*** 135% Operating time of less than 4 amps.

Recommended fuse panels, holders and fuseclips:

Catalog No.	Description	Max amps	Lead wire length/size
FP-ATC-(poles)ID	easyID fuse panel with cover, 4-, 6- and 10-pole versions	100	1/4" quick-connect
BP/FB(poles)-ATC	Splash-proof fuse block with cover, 4-, 6-, 8- and 10-pole versions	20 per pole	1/4" quick-connect
15600-(poles)-20	ATC Fuse panel in 4- to 20-poles	20	—
HHC	Yellow, water resistant in-line fuse holder	20	2x4"/#16
HHD	Black, heavy-duty in-line fuse holder	30	2x4"/#12
HHF	Black, in-line fuse holder w/cover	20	2x4"/#14
HHG	Black, heavy-duty in-line fuse holder w/cover	30	2x4"/#12
HHR	Heavy-duty, water resistant in-line fuse holder	30	2x5"/#12
BP/HHS-RP	Self-stripping in-line fuse holder	20	#18 to #14
BP/HHA-RP	Add-a-Fuse	10	N/A
ATC-FHID	Illuminating in-line fuse holder	20	2x6"/#16
1A5600†	PCB fuseclip	20	—
1A5780†	PCB fuseclip	15	—

† See data sheet no. 2131 for details.

Dimensions — mm:

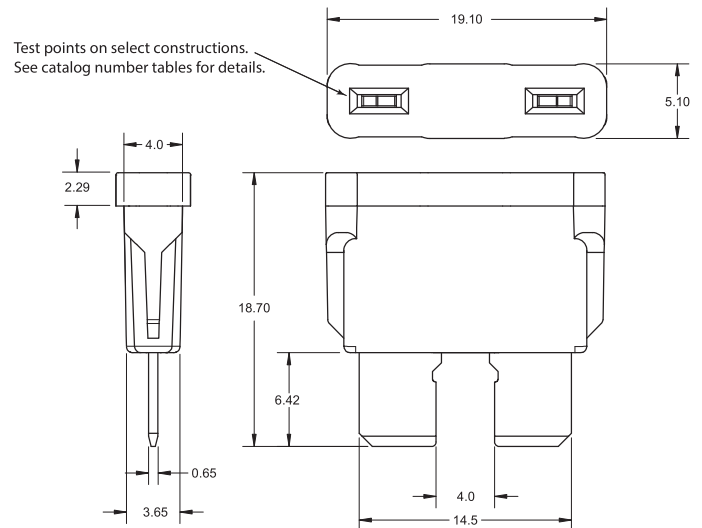

Dimensions shown are basic for all ampacities, constructions and housing materials.

Time-current characteristic curves — average melt - for all fuse constructions/housing materials

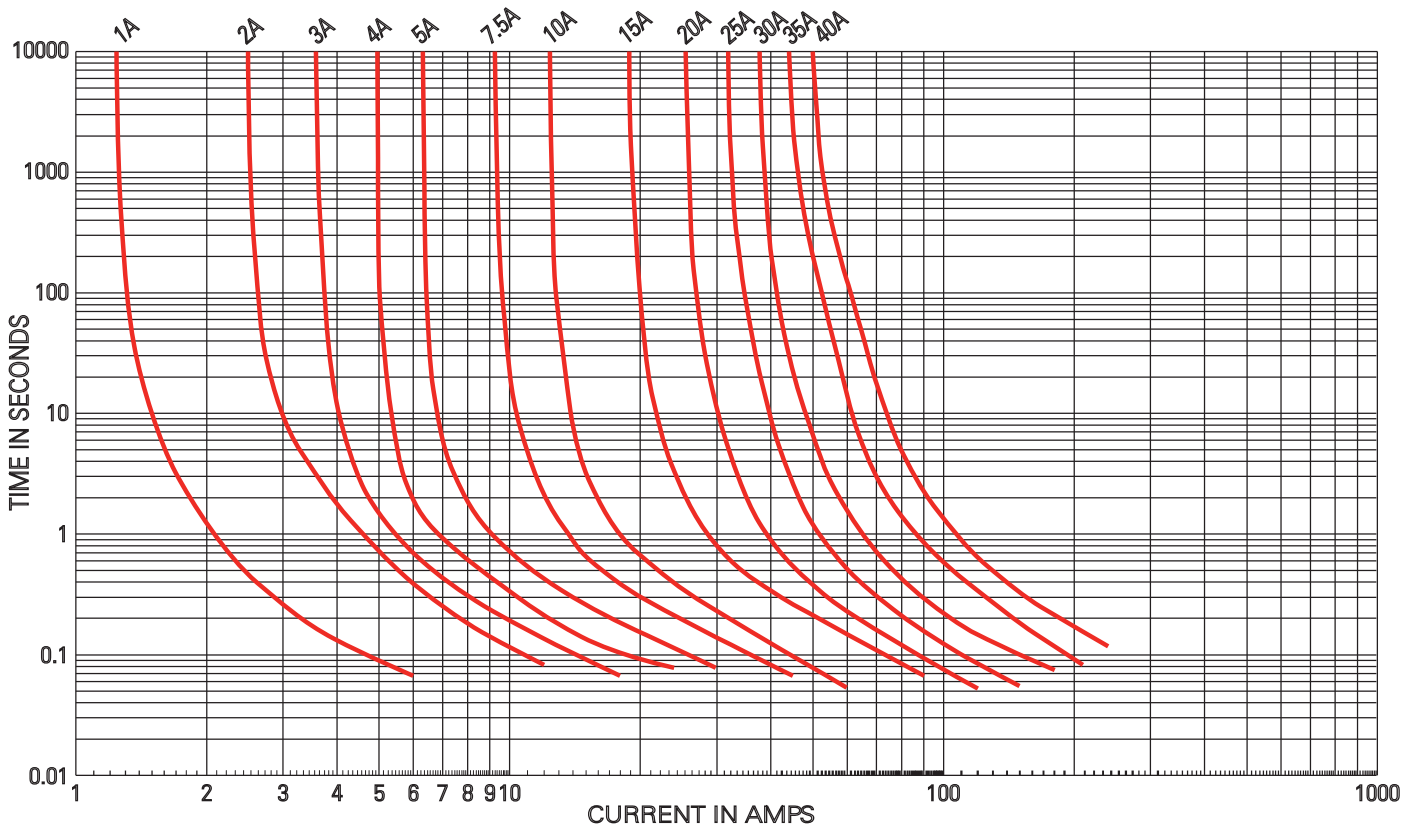

ATC fuse construction and housing material availability by catalog number

ATC fuse catalog number availability for closed body housing with test points and SAE J1171 ignition protected

Reload	Bulk packs*	Blister packs	5-in tins**	Value packs	Assortments	Housing material
—	BK/ATC-1	BP/ATC-1-RP	ATC-1	—	BP/ATC-A5-RP (fuse assortment)	Polycarbonate
—	BK/ATC-2	BP/ATC-2-RP	ATC-2	—	BP/ATC-AH8-RPP (fuse emergency kit)	Polycarbonate
ATC-3RLD	BK/ATC-3	BP/ATC-3-RP	ATC-3	—	BP/ATC-AL8-RP (low amp assortment)	Polycarbonate
ATC-4RLD	BK/ATC-4	BP/ATC-4-RP	ATC-4	—	DIA-1 (diagnostic kit)	Polycarbonate
ATC-5RLD	BK/ATC-5	BP/ATC-5-RP	ATC-5	VP/ATC-5RP	NO.44 (fuse emergency kit)	Polycarbonate
ATC-7½RLD	BK/ATC-7½	BP/ATC-7½-RP	ATC-7½	VP/ATC-7½-RP	NO.80 (bulk assortment)	Polycarbonate
ATC-10RLD	BK/ATC-10	BP/ATC-10-RP	ATC-10	VP/ATC-10-RP	NO.95BK (ATC/ATM bulk assortment)	Polycarbonate
ATC-15RLD	BK/ATC-15	BP/ATC-15-RP	ATC-15	VP/ATC-15-RP	NO.53 (ATC/MAX fuse emergency kit)	Polycarbonate
ATC-20RLD	BK/ATC-20	BP/ATC-20-RP	ATC-20	VP/ATC-20-RP	NO.160BK (bulk assortment)	Polyamide
ATC-25RLD	BK/ATC-25	BP/ATC-25-RP	ATC-25	VP/ATC-25-RP	NO.225 (tilt bin assortment)	Polyamide
ATC-30RLD	BK/ATC-30	BP/ATC-30-RP	ATC-30	VP/ATC-30-RP	—	Polyamide
—	BK/ATC-35	—	ATC-35	—	—	Polyethersulfone
—	BK/ATC-40	BP/ATC-40-RP	ATC-40	—	—	Polyethersulfone
—	—	—	—	—	CDY10TRY-ATC (fuse tray)***	—
—	—	—	—	—	NO.290†	—

* 2000 fuses per pack.
 ** 5 fuses per tin.
 *** Contains (5 each) – ATC 3, 4, 5, and 7½A
 (10 each) – ATC 10, 15, 20, 25, 30, 35 and 40A
 † Contains one 5-in tin each of ATC 3, 4, 5, 7-1/2, 10, 15, 20, 25, 30, 35 and 40A. See poly material column for details on the fuses in each tin of this assortment.

The only controlled copy of this data sheet is the electronic read-only version located on the Eaton network drive. All other copies of this document are by definition uncontrolled. This bulletin is intended to clearly present comprehensive product data and provide technical information that will help the end user with design applications. Eaton reserves the right, without notice, to change design or construction of any products and to discontinue or limit distribution of any products. Eaton also reserves the right to change or update, without notice, any technical information contained in this bulletin. Once a product has been selected, it should be tested by the user in all possible applications.

Eaton
 1000 Eaton Boulevard
 Cleveland, OH 44122
 Eaton.com

 Bussmann Division
 114 Old State Road
 Ellisville, MO 63021
 United States
 Eaton.com/bussmannseries

© 2019 Eaton
 All Rights Reserved
 Printed in USA
 Publication No. 2009 — BU-MC19152
 December 2019

Eaton and Bussmann are valuable trademarks of Eaton in the U.S. and other countries. You are not permitted to use the Eaton trademarks without prior written consent of Eaton.

SAE is a registered trademark of the Society of Automotive Engineers.
 UL is a registered trademark of the Underwriters Laboratories, Inc.

For Eaton's Bussmann series product information, call 1-855-287-7626 or visit: Eaton.com/bussmannseries

Follow us on social media to get the latest product and support information.

