

# DATA SHEET

## DIRECT DRIVE PLUNGER PUMPS



**Brass Electric Models: 2SFX20ES, 2SFX30ES**

**Brass Gas Models: 2SFX30GS, 2SFX30GZ**

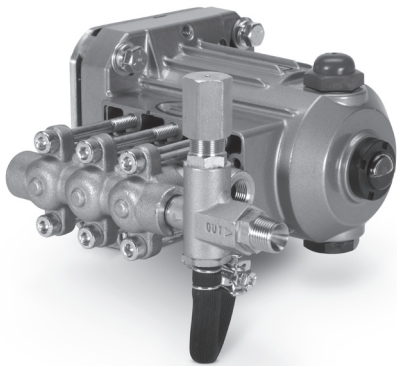

Model 2SFX30GS Shown  
(Unloader and bypass hose included with pump)

### FEATURES

- Available in two configurations: hollow-shaft pump for direct mounting to gas engine or electric motor, or as complete motorized units.
- Includes regulating unloader, bypass hose and crankcase oil.
- Pump comes standard with NBR seals. Alternative seal materials are available for higher temperature or chemical compatibility.

### COMMON SPECIFICATIONS

	U.S.	Metric
Inlet Pressure Range	Flooded to 75 psi	Flooded to 5.2 bar
Pump RPM	3450 rpm	3450 rpm
Bore	0.708"	18 mm
Max. Liquid Temperature (NBR)	160° F	71° C

### Alternate seals available for higher temperatures up to 180° F

Crankcase Capacity	10.1 oz	0.3 l
Inlet Port (1)	3/8" NPT(F)	3/8" NPT(F)
Discharge Port (1) *	3/8" NPT(F)	3/8" NPT(F)
Discharge Port (1)	3/8" NPT(M)	3/8" NPT(M)
Bypass Port (1)	1/4" NPT(F)	1/4" NPT(F)
Weight (Pump Only)	11.83 lbs	4.8 kg
Dimensions (Pump Only)	9.13 x 6.65 x 6.50"	232 x 169 x 165 mm

\*2SFX30GZ Discharge manifold has a closed port on the engine side.

### SPECIFICATIONS

	U.S. Measure	Metric Measure
<b>2SFX20ES</b>		
Flow	2.0 gpm	7.6 lpm
Max. Discharge Pressure	2000 psi	138 bar
Stroke	0.122"	3.1 mm
<b>2SFX30ES</b>		
Flow	3.0 gpm	11.4 lpm
Max. Discharge Pressure	1500 psi	103 bar
Stroke	0.181"	4.6 mm
<b>2SFX30GS</b>		
Flow	3.0 gpm	11.4 lpm
Max. Discharge Pressure	2000 psi	138 bar
Stroke	0.189"	4.8 mm
<b>2SFX30GZ</b>		
Flow	3.0 gpm	11.4 lpm
Max. Discharge Pressure	2500 psi	172 bar
Stroke	0.189"	4.8 mm

ES = **Electric** 5/8" hollow shaft with bolt mount, NEMA 56C

GS, GZ = **Gas** 3/4" hollow shaft with bolt mount and adapter.

Gas Mounting Flange: SAE J609, Flange A, Extension 3 (3/4" Ø),

Shaft Length = 2.296, Pilot Ø = 1 1/8", B.C. Ø = 3 5/8", Thread = 5/16"- 24 UNC Tap

Refer to pump **Service Manual** for repair procedures and additional technical information.

### ALTERNATIVE SEAL CONFIGURATION

MATERIAL	SUFFIX CODE	MAXIMUM TEMPERATURE	
NBR	—	160° F	(71° C)
FPM	.0110	180° F	(82° C)
EPDM	.0220	160° F	(71° C)
HT	.3000	180° F	(82° C)

See **Tech Bulletin 002** for inlet conditions and RPM at high-temperature.

### ELECTRIC HORSEPOWER REQUIREMENTS

MODELS	FLOW		PRESSURE						PUMP RPM			
	GPM	LPM	1200		1500		2000					
			PSI	BAR	PSI	BAR	PSI	BAR				
2SFX20ES	2.0	7.6	1.6 hp	83	2.1hp	103	2.7 hp	138	2500	172	N/A	3450
2SFX30ES	3.0	11.4	2.5 hp	83	3.1 hp	103	4.1 hp	138	2500	172	5.1 hp	3450

### DETERMINING

**THE REQUIRED HP**

$$\text{hp (Electric Brake)} = \frac{\text{gpm} \times \text{psi}}{1460}$$

$$\text{hp (Gas Brake)} = \frac{\text{gpm} \times \text{psi}}{1140}$$

# PARTS LIST

ITEM	PART NUMBER	MATL	DESCRIPTION	MODEL USED	QTY
5	549360	STCP R	Screw, HH (M6 x 14) (See Tech Bulletins 074, 092)	All Models	3
8	547153	AL	Cover, Bearing, Inner (See Tech Bulletin 092)	All Models	1
10	14041	NBR	O-Ring, Bearing Cover-70D (See Tech Bulletin 092)	All Models	1
11	55337	NBR	Seal, Oil (See Tech Bulletin 092)	All Models	1
15	14488	STL	Bearing Inner, Ball	All Models	1
20	547046	TNM	Rod, Connecting	All Models	3
24	549608	LPDE	Plug, Oil Cap (Remove Before Start-Up)	All Models	1
25	<b>46109</b>	FCM	Crankshaft, 3450 RPM, 5/8" (3.1mm)	2SFX20ES	1
	<b>832644</b>	FCM	Crankshaft, 3450 RPM, 5/8" (4.6mm)	2SFX30ES	1
	<b>546334</b>	FCM	Crankshaft, 3450 RPM, 3/4" (4.8mm)	GS, GZ Models	1
26	12385	STL	Ring, Retaining	All Models	1
27	15710	STL	Bearing Outer, Ball	All Models	1
31	549726	—	Cap, Vented with O-Rings (Rain Cap)	All Models	1
32	547961	RTP	Cap, Oil Filler with O-Ring	All Models	1
33	14179	NBR	O-Ring, Oil Filler Cap-70D	All Models	1
37	92241	PC	Gauge, Oil, Bubble with Gasket (See Tech Bulletin 074)	All Models	1
38	44428	NBR	Gasket, Oil Gauge-80D	All Models	1
48	44842	NY	Plug, Drain (1/2" NPT[F])	All Models	1
49	14179	NBR	O-Ring, Drain Plug-70D	All Models	1
53	547285	AL	Crankcase (See Tech Bulletin 092)	All Models	1
64	16948	CM	Pin, Crosshead	All Models	3
65	<b>540073</b>	SZZ	Rod, Plunger, Unchromed	2SFX20, 30	3
	<b>542958</b>	SHS	Rod, Plunger	2SFX30GZ	3
69	126259	STCP R	Washer (M24)	All Models	3
70	25461	NBR	Seal, Oil	All Models	3
90	45847	CC	Plunger (M18 x 14)	All Models	3
100	44869	PVDF	Retainer, Seal	All Models	3
106	† 44876	NBR	Seal, Low-Pressure with SS-Spring	All Models	3
	545192	FPM	Seal, Low-Pressure with SS-Spring	All Models	3
	◆ 546507	EPDM	Seal, Low-Pressure with SS-Spring	All Models	3
110	44874	BB	Manifold, Inlet	All Models	1
125	43245	SNG	Seal, High-Pressure with S-Support	All Models	3
	46652	HT	Seal, High-Pressure, High-Temperature, 2-Piece with S-Support (See Tech Bulletin 073)	All Models except GZ	3
	76052	ST4	Seal, High-Pressure with S-Support	All Models	3
134	45854	S	Valve, Inlet	All Models	3
	33873	D	Valve, Inlet, High-Temperature	All Models	3
135	549520	S	Spacer	All Models	3
136	44872	S	Spring, Inlet	All Models	3
137	88575	S	Washer, Conical (M6)	All Models	3
138	81240	SS	Nut, Hex (M6) (See Tech Bulletin 074)	All Models	3
152	† 26089	NBR	O-Ring, Adapter-80D	All Models	3
	11377	FPM	O-Ring, Adapter-80D	All Models	3
	◆ 46647	EPDM	O-Ring, Adapter-80D	All Models	3
157	<b>45859</b>	BB	Adapter, Discharge, Seat	All Models except GZ	3
	<b>44878</b>	BB	Spacer, Discharge, Valve	2SFX30GZ	3
159	† 26089	NBR	O-Ring, Adapter-80D	All Models	3
	11377	FPM	O-Ring, Adapter-80D	All Models	3
	◆ 46647	EPDM	O-Ring, Adapter-80D	All Models	3
164	<b>44881</b>	S	Seat	2SFX30GZ	3
166	43723	S	Valve	All Models	3
167	541062	S	Spring	All Models	3
168	44565	PVDF	Retainer, Spring	All Models	3
185	† 44879	BB	Manifold, Discharge	All Models	1
188	126762	STCP R	Screw, HSH (M8 x 75) (See Tech Bulletin 074)	All Models	6
197	941516	BB	GH Assembly, (3/8" NPT[M] x 3/4" GH[F])	All Models	1
249	30520	—	Assembly, Adapter Mount, Gas	All Gas Models	1
255	30517	STZP	Assembly, Bolt Mount	All Models	1
285	80228	STL	Screw (M8 1.25 x 80) (Not Shown)	All Models	2
300	34053	NBR	Kit, Seal (Includes: 106, 125, 152, 159) <b>Standard</b>	All Models	1
	33953	HT	Kit, Seal, High-Temperature (Includes: 106, 125, 134, 152, 159) <b>.3000</b> (See Tech Bulletin 073)	All Models	1
	33453	FPM	Kit, Seal (Includes: 106, 125, 152, 159) <b>.0110</b>	All Models	1
	◆ 30536	EPDM*	Kit, Seal (Includes: 106, 125, 152, 159) <b>.0220</b>	All Models	1

# EXPLODED VIEW

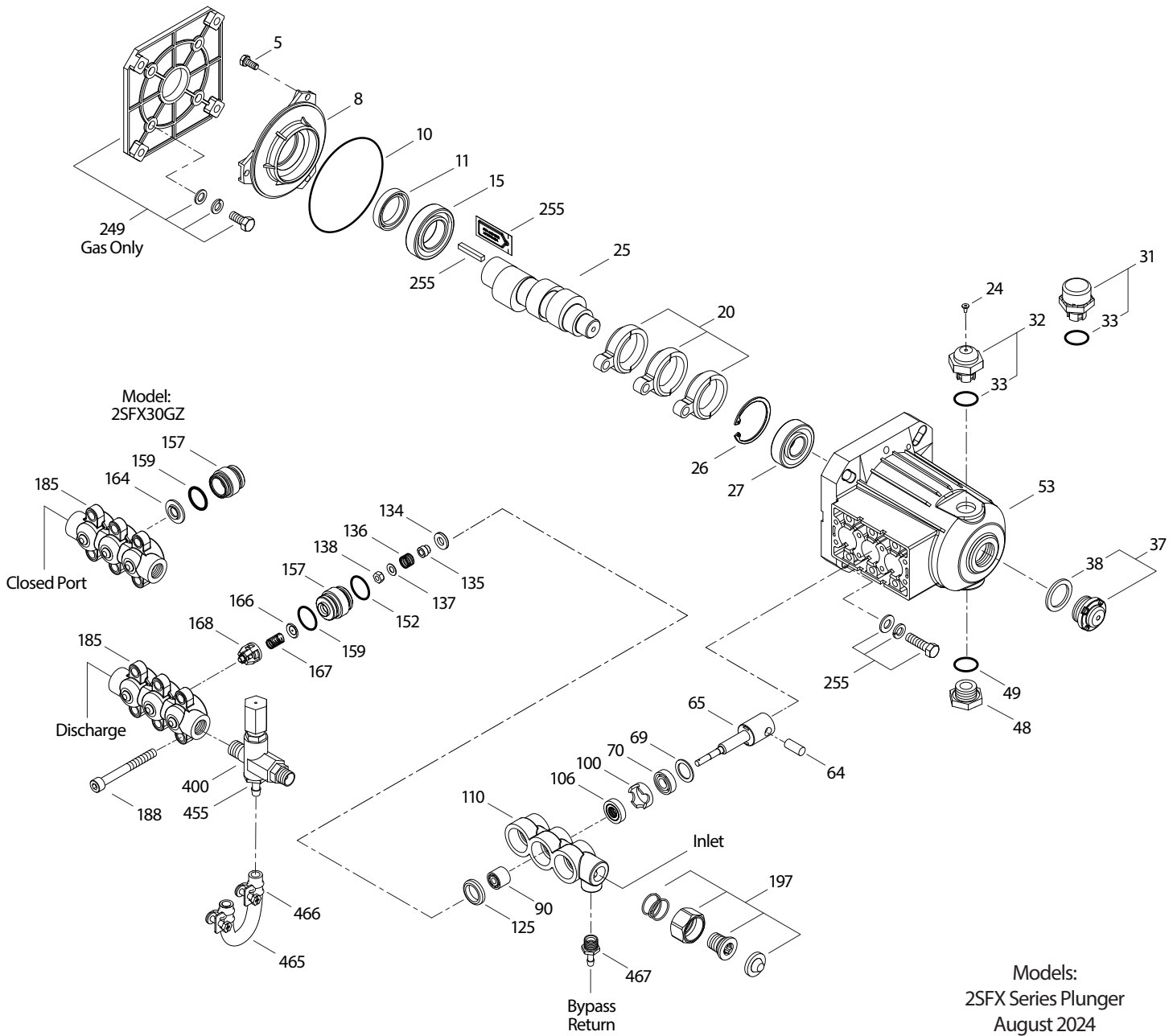

ITEM	PART NUMBER	MATL	DESCRIPTION	MODEL USED	QTY
310	34056	NBR	Kit, Discharge Valve (Includes: 152, 157, 159, 166, 167, 168) <b>Standard, .3000</b>	All except GZ	1
	34052	NBR	Kit, Discharge Valve (Includes: 152, 159, 164, 166, 167, 168) <b>Standard</b>	2SFX30GZ	1
311	34668	NBR	Kit, Inlet Valve (Includes: 134–137, 152, 159) <b>Standard</b>	All Models	1
400	<b>7500XS</b>	BB	Unloader, Regulating	Standard 2SFX Models	1
	<b>7625</b>	BB	Unloader, Regulating	2SFX30GZ	1
—	6107	—	Oil, Bottle (21 oz) (Fill to Specified Crankcase Capacity prior to Start-up)	All Models	1

**Bold Part Numbers are unique to a particular pump model.**

*Italics are optional items.* † Production parts are different than service parts.

\*Review individual parts in each kit for material identification. R Components comply with RoHS Directive.

For additional technical information see [www.catpumps.com/literature/tech-bulletins](http://www.catpumps.com/literature/tech-bulletins).

Effective with 1/90 Mfg. date 45853, 14036, 44861, 92519 have been replaced with new one piece crankcase.

Note: Discard Key which may come standard with most motors and engines and **use only the key included in this kit.**

MATERIAL CODES (Not Part of Part Number): AL=Aluminum BB=Brass CC=Ceramic CM=Chrome-moly D=Acetal EPDM=Ethylene Propylene Diene Monomer  
 FCM=Forged Chrome-moly FPM=Fluorocarbon HT=Hi-Temp (EPDM Alternative) LPDE=Low Density Polyethylene NBR=Medium Nitrile (Buna-N) NY=Nylon  
 PC=Poly Carbonate PVDF=Polyvinylidene Fluoride RTP=Reinforced Composite S=304SS SHS=304SS/High Strength SNG=Special Blend (Buna)  
 SS=316SS ST4=Special PTFE 4 STL=Steel STCP=Steel/Chrome-Plated STZP=Steel/Zinc Plated SZZ=304SS/Zamak TNM=Special High Strength

Center raised pilot guide on the **Adapter Plate** ensures proper alignment of pump and engine. Before mounting pump onto engine, inspect engine for **recessed seal and bearing guide** to permit adapter to completely seat into recess and four bosses to be flush with engine face.

# 7500XS UNLOADER for "ES" and "GS" Pump Models

## SPECIFICATIONS

	U.S.	Metric
Flow Range	0.5–6.0 gpm	2–23 lpm
Pressure Range	100–2000 psi	6.9–138 bar
Maximum Temperature	190° F	88° C
Inlet Port, Rear	3/8" NPT(M)	3/8" NPT(M)
Discharge Port, Front	3/8" NPT(M)	3/8" NPT(M)
Bypass Port, Barb	1/4"	1/4"
Weight	14 oz	0.40 kg
Dimensions	3.0 x 1.0 x 4.25"	76.2 x 25.4 x 108 mm

## PARTS LIST

ITEM	P/N	MATL	DESCRIPTION	QTY
401	32088	NY	Handle, Black	1
402	540081	BB	Cap, Adjusting	1
403	31047	BB	Nut, Lock	1
408	32094	STZP R	Spring, Pressure	1
410	107672	BB	Retainer, Spring	1
412	45694	S	Stem (M5)	1
414	—	PTFE	Backup Ring, Piston Stem	1
415	—	NBR	O-Ring, Piston Stem-70D	1
425	107673	BB	Retainer, Piston	1
428	—	NBR	O-Ring, Retainer-70D	1
429	—	NBR	O-Ring, Body	1
430	—	PTFE	Backup Ring, Body	1
435	45696	BB	Valve and Ball Assembly (M5)	1
436	107680	S	Seat	1
437	—	NBR	O-Ring, Seat-70D	1
440	—	BB	Body	1
442	—	NBR	O-Ring, Bypass Fitting-70D	1
443	541060	BB	Valve, Check with O-Ring	1
	549468	SS	Valve, Check with FPM O-Ring	1
	831515	SS	Valve, Check with EPDM O-Ring	1
444	45924	S	Spring, Check Valve	1
446	—	NBR	O-Ring, Discharge Fitting-70D	1
455	45865	BB	Barb, Hose, Bypass Fitting	1
460	107681	BB	Fitting, Discharge (3/8" NPT[M])	1
465	46140	—	Bypass Hose (5 1/2" x 1/4")	1
	45983	—	Bypass Hose (8 1/2" x 1/4") (UMS)	1
466	34365	S	Clamp, Hose	2
467	45868	BB	Barb, Hose, Inlet Manifold	1
468	32097	NBR	Kit, O-Ring <b>Standard</b> , .3000 (Includes: 414, 415, 428, 429, 430, 437, 442, 446)	1
	31627	FPM	Kit, O-Ring <b>.0110</b> (Includes: 414, 415, 428, 429, 430, 437, 442, 446)	1
	31959	EPDM	Kit, O-Ring <b>.0220</b> (Includes: 414, 415, 428, 429, 430, 437, 442, 446)	1
471	32176	NBR	Kit, Check Valve (Includes: 443, 444, 446)	1

## EXPLODED VIEW

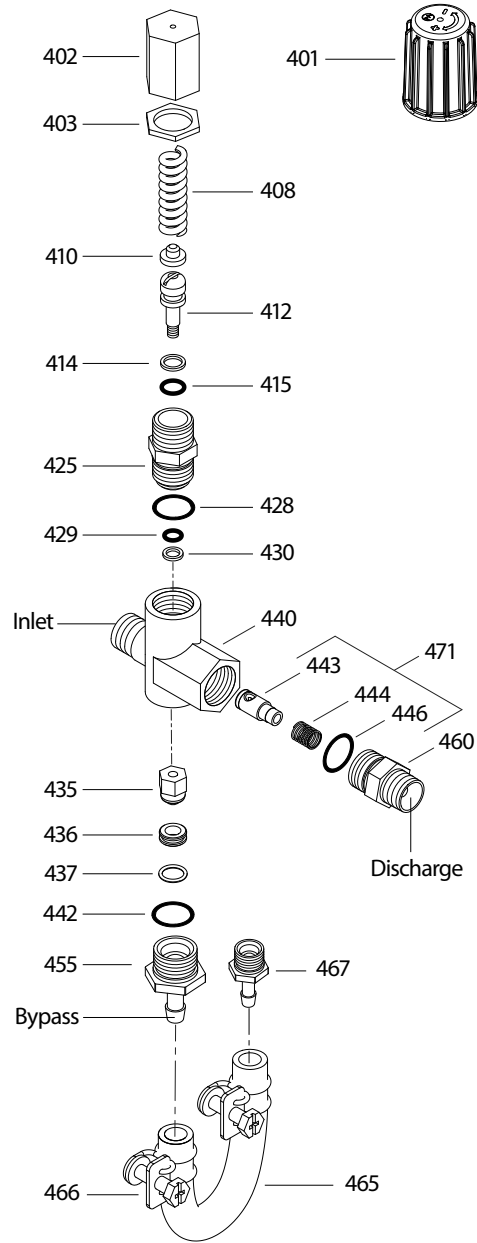

*Italics are optional items.* R Components comply with RoHS Directive.

MATERIAL CODES (Not Part of Part Number): BB=Brass EPDM=Ethylene Propylene Diene Monomer FPM=Fluorocarbon NBR=Medium Nitrile (Buna-N) NY=Nylon  
PTFE=Pure Polytetrafluoroethylene S=304SS STZP=Steel/Zinc Plated

# 7625 UNLOADER for "GZ" Pump Models

## SPECIFICATIONS

	U.S.	Metric
Flow Range	0.5–7.8 gpm	2–30 lpm
Pressure Range	100–2500 psi	6.9–172 bar
Maximum Temperature	194° F	90° C
Inlet Port, Rear	3/8" BSP(M)	3/8" BSP(M)
Discharge Port, Front	3/8" BSP(F)	3/8" BSP(F)
Bypass Port, Barb	1/4"	1/4"
Auxiliary Port, Side	1/4" BSP(F)	1/4" BSP(F)
Weight	19.5 oz	0.55 kg
Dimensions	3.2 x 1.5 x 4.7"	81 x 38 x 119.4 mm

## PARTS LIST

ITEM	P/N	MATL	DESCRIPTION	QTY
401	32088	NY	Handle, Black	1
402	33859	BB	Cap, Adjusting	1
403	33857	BB	Nut, Lock (M18 x 1)	1
404	33061	STZP	Screw, Set (M4 x 4)	1
408	32094	STZP R	Spring, Pressure	1
410	32819	STZP	Retainer, Spring	1
412	33860	S	Stem, Valve with O-Ring and Backup Ring	1
414	—	PTFE	Backup Ring, Stem	1
415	—	NBR	O-Ring, Stem	1
425	33861	BB	Retainer, Piston	1
428	—	NBR	O-Ring, Retainer	1
429	—	NBR	O-Ring, Body	1
430	—	PTFE	Backup Ring, Body	1
435	33853	SSS	Valve and Ball Assembly (M6)	1
436	33806	NBR	Seat, with O-Ring	1
437	—	NBR	O-Ring, Seat	1
440	—	BB	Valve Body	1
442	—	NBR	O-Ring, Bypass Fitting–85D	1
443	76736	BB	Valve, Check with O-Ring	1
444	33843	S	Spring	1
446	—	NBR	O-Ring, Discharge Fitting	1
454	33865	BB	Barb, Bypass (3/8" BSP[M] x 1/4")	1
455	33846	BB	Fitting, Bypass (3/8" BSP[F])	1
460	33847	BB	Fitting, Discharge (3/8" BSP[F])	1
465	46140	—	Bypass Hose (5 1/2" x 1/4")	1
466	34365	S	Clamp, Hose	2
467	45868	BB	Barb, Hose, Inlet Manifold	1
468	76781	NBR	Kit, O-Ring (Includes: 414, 415, 428, 429, 430, 437, 442, 446)	1

*Italics are optional items.* R Components comply with RoHS Directive.  
 MATERIAL CODES (Not Part of Part Number): BB=Brass  
 NBR=Medium Nitrile (Buna-N) NY=Nylon PTFE=Pure Polytetrafluoroethylene  
 S=304SS SSS=416SS STZP=Steel/Zinc Plated

## EXPLODED VIEW

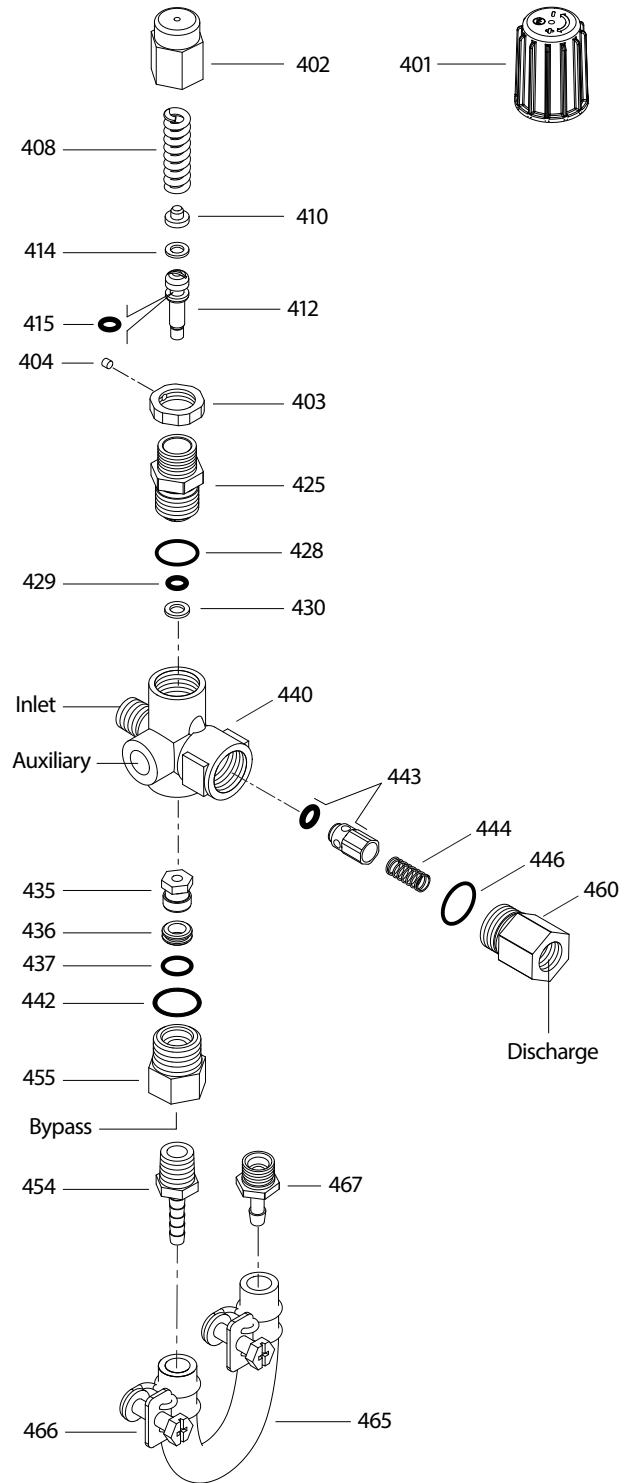

## OPTIONAL CHEMICAL INJECTORS

### 7192, 7193, 7194, 7224 ADJUSTABLE, DOWN STREAM SPECIFICATIONS

		U.S.	Metric
Flow Range	7192	2–4 gpm	7.6–15 lpm
	7193	3–5 gpm	11.4–19 lpm
	7194	3–6 gpm	11.4–23 lpm
	7224	5–6 gpm	19–23 lpm
Orifice Size	7192	1.8 mm	1.8 mm
	7193	2.1 mm	2.1 mm
	7194	2.3 mm	2.3 mm
	7224	2.3 mm	2.3 mm
Maximum Pressure		4050 psi	279 bar
Maximum Temperature		195° F	90° C
Inlet Port (7192, 7193, 7194)		M18 x 1.0	M18 x 1.0
Inlet Port (7224)		M22 x 1.5	M22 x 1.5
Discharge Port		3/8" NPT(M)	3/8" NPT(M)
Hose Barb		1/4"	1/4"
Weight		5.7 oz	0.16 kg
Dimensions		2.0 x 1.0 x 3.0"	50.8 x 25.4 x 76.2 mm

## EXPLODED VIEW

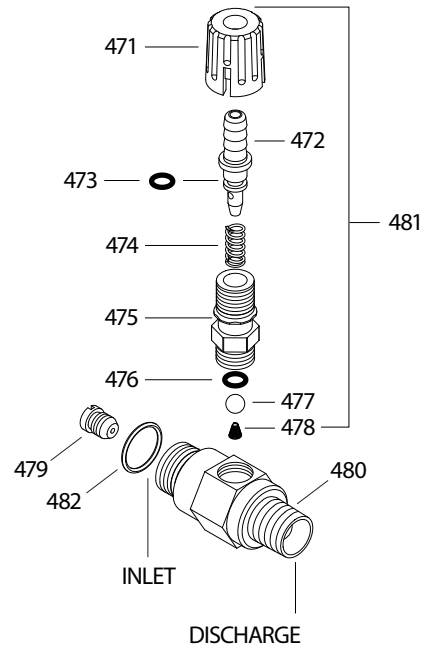

## CHEMICAL INJECTOR PERFORMANCE CHART

Model	Pump Flow	Orifice Size	Maximum Injecting Pressure	Maximum Chemical Draw	Pressure Drop Across Orifice
7192	2 gpm	1.8	225 psi	60	150
7192	3 gpm	1.8	275 psi	60	300
7192	4 gpm	1.8	450 psi	60	500
7193	3 gpm	2.1	225 psi	54	150
7193	4 gpm	2.1	375 psi	54	250
7193	5 gpm	2.1	600 psi	54	400
7194	3 gpm	2.3	150 psi	50	125
7194	4 gpm	2.3	225 psi	50	220
7224	3 gpm	2.3	150 psi	50	125
7224	4 gpm	2.3	225 psi	50	220

Optimum performance of chemical injector occurs with a 35 ft high-pressure hose with a minimum 3/8" ID. The type of hose, extended lengths, reduced ID and fittings may create additional back pressures above the maximum injecting pressure rating of the injector and prevent it from drawing chemical.

## PARTS LIST

ITEM	P/N	MATL	DESCRIPTION	MODEL USED	QTY
471	33949	NY	Handle, Adjustment	All	1
472	32941	BB	Barb, Adjustable with O-Ring	All	1
473	—	NBR	O-Ring, Hose Barb	All	1
474	33500	S	Spring, Retainer	All	1
475	33946	BB	Retainer, Ball/Seat	All	1
476	33504	FPM	O-Ring, Retainer	All	1
477	34620	SS	Ball, Seat 1/4"	All	1
478	33501	SS	Spring, Ball	All	1
479	<b>32372</b>	S	Injector Orifice (1.8 mm)	7192	1
	<b>32373</b>	S	Injector Orifice (2.1 mm)	7193	1
	<b>32374</b>	S	Injector Orifice (2.3 mm)	7194	1
	<b>32074</b>	SSS	Injector Orifice (2.3 mm)	7224	1
480	—	BB	Body	All	1
481	33481	BBNY	Barb Assembly, Adjustable (Includes: 471, 472, 473, 474, 475, 476, 477, 478)	All	1
482	13969	NBR	O-Ring, Body-70D	All	1

*Italics are optional items.*  
 Material Codes (Not Part of Part No.): BB=Brass FPM=Fluorocarbon  
 NBR=Medium Nitrile (Buna-N) NY=Nylon S=304SS SS=316SS SSS=416SS

## TROUBLESHOOTING

PROBLEM	PROBABLE CAUSE	SOLUTION
No Chemical Draw:	<ul style="list-style-type: none"> <li>High-pressure nozzle installed on gun</li> <li>Air leak in chemical suction line</li> <li>Worn injector orifice</li> </ul>	<ul style="list-style-type: none"> <li>Install low-pressure nozzle in gun</li> <li>Tighten or replace suction line</li> <li>Replace injector orifice</li> </ul>
Leaking Around Adjusting Collar:	<ul style="list-style-type: none"> <li>Worn O-ring</li> <li>Debris in injector</li> </ul>	<ul style="list-style-type: none"> <li>Replace O-ring</li> <li>Clean out debris from injector</li> </ul>

## ELECTRIC MOTOR SPECIFICATIONS (60 hz, 1 hp)

Contact Cat Pumps for additional motor options including the 3 ph, 50 hz, frame sizes, etc.

**Note:** Use a 1750 RPM motor to reduce the flow rate of a 3450 RPM pump by 50%

### Model 8054

Horsepower	1.5
Shaft Diameter	5/8"
Maximum Volts	115/230
Full Load Amps	12.1
RPM	3450
Weight	32.1 lbs
Phase	Single
Frame Size	56C TEFC
Service Factor	1.15

Motor has thermal overload manual reset.

### Model 999943

Horsepower	2.0
Shaft Diameter	5/8"
Maximum Volts	115/230
Full Load Amps	17.0/9.2–8.5
RPM	3450
Weight	32.5 lbs
Phase	Single
Frame Size	56C TEFC
Service Factor	1.15

Motor has thermal overload manual reset.

### Model 8126

Hertz	60	50
Horsepower	2.5	2.5
Shaft Diameter	5/8"	5/8"
Maximum Volts	208–230/460	190–220/380–415
Full Load Amps	7.9–7.12/3.56	8.2–7.6/4.08–4.01
RPM	1750	1450
Weight	63 lbs	63 lbs
Phase	Three	Three
Frame Size	56C TEFC	56C TEFC
Service Factor	1.15	1.0

### Model 8057

Horsepower	5.0
Shaft Diameter	3/4"
Maximum Volts	230
Full Load Amps	22.0
RPM	3450
Weight	40 lbs
Phase	Single
Frame Size	56C Open Drip
Service Factor	1.15

Motor has thermal overload manual reset.

### Model 8115

Hertz	60	50
Horsepower	1.5	1.5
Shaft Diameter	5/8"	5/8"
Maximum Volts	115/208–230	110/220
Full Load Amps	13.8/7.63–6.90	17.8/8.90
RPM	1750	1450
Weight	53.8 lbs	53.8 lbs
Phase	Single	Single
Frame Size	56C TEFC	56C TEFC
Service Factor	1.85	1.65

### Model 8120

Hertz	60	50
Horsepower	2.0	2.0
Shaft Diameter	5/8"	5/8"
Maximum Volts	115/208–230	110/220
Full Load Amps	17.2/9.53–8.62	20.8/10.4
RPM	1750	1450
Weight	53.8 lbs	53.8 lbs
Phase	Single	Single
Frame Size	56C TEFC	56C TEFC
Service Factor	1.40	1.25

### Models 8125/8125W

Hertz	60	50
Horsepower	2.5	2.2
Shaft Diameter	5/8"	5/8"
Maximum Volts	115/230	110/220
Full Load Amps	20.8/10.4	22/11
RPM	1750	1450
Weight	53.8 lbs	53.8 lbs
Phase	Single	Single
Frame Size	56HC TEFC	56HC TEFC
Service Factor	1.15	1.15

### Common Motor Specifications

Maximum Ambient Temperature	104° F
Hertz	60 Hz
Capacitor Start	Yes

**Note:** Motor start-up AMPS may vary, then settle within FULL LOAD AMPS rating after initial run-in time.

Before mounting pump on motor, apply PN 6106 Anti-Seize lubricant to pump shaft.

Refer to **Tech Bulletin 055** for instructions on removing pump from gas engine or electric motor.

## MOTOR DIMENSIONS

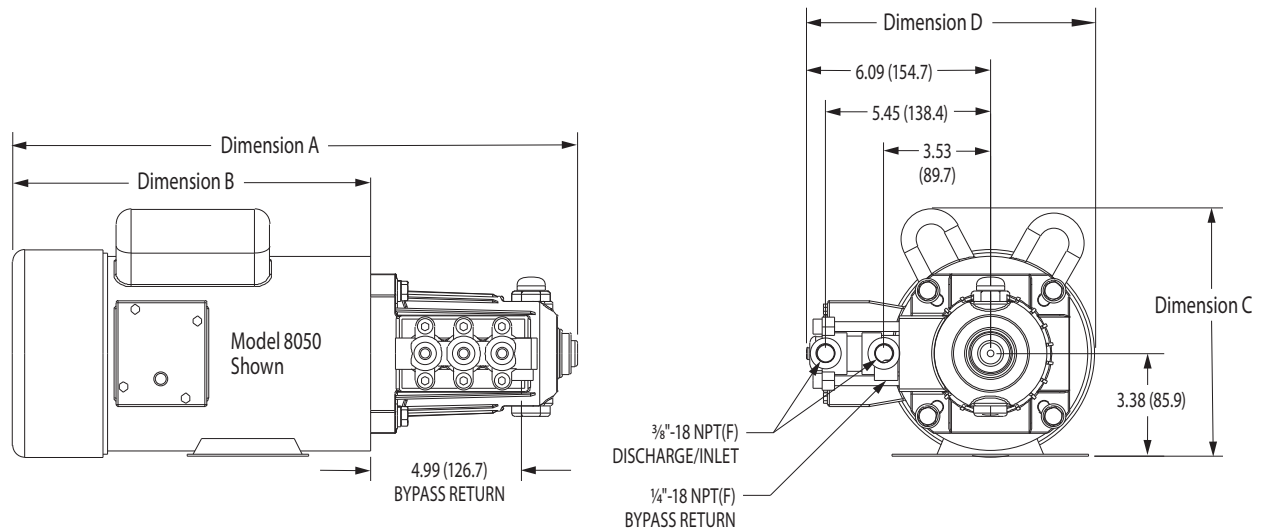

MODEL	8054	999943	8057	8115	8120	8125/W	8126
Dimension A	18.2 (462)	18.2 (462)	18.7 (475)	19.3 (490)	19.3 (490)	19.3 (490)	20.0 (525)
Dimension B	11.3 (287)	11.3 (287)	11.8 (300)	12.4 (315)	12.4 (315)	12.4 (315)	13.1 (350)
Dimension C	8.4 (213)	8.4 (213)	9.0 (228)	9.7 (246)	9.7 (246)	9.7 (246)	8.3 (185)
Dimension D	9.5 (241)	9.5 (241)	9.5 (241)	9.7 (246)	9.7 (246)	9.7 (246)	9.5 (246)

## UNLOADER TYPE

Each pump comes with a pressure-sensitive regulating unloader. This unloader will set system pressure. While in bypass, the line pressure will drop to a low-pressure mode and then quickly build up to set system pressure when the system is back to full use.

## INSTALLATION AND START-UP

Install a pressure gauge close to the manifold head of the pump to assist in setting system pressure, and to periodically monitor system pressure. This pump comes with a bypass line and is redirected to the 1/4" NPT(F) port on bottom side of inlet manifold.

**Note:** If not using a thermal valve, **DO NOT EXCEED 6 MINUTES** in bypass.

**Note:** For high-temperature seal pumps, **DO NOT USE THERMAL VALVE.** Use optional dual pressure switches and mechanical relays.

Pump should be purged of air before commencing with operation. Liquid must flow through the pump without discharge restriction to ensure full system pressure is reached.

Setting and adjusting the unloader pressure must be done with the system turned on. Start the system with the unloader backed off to the lowest pressure setting (counterclockwise direction). Squeeze the trigger and read the pressure on the gauge at the pump. Do not read pressure at the gun or nozzle. If more pressure is desired, release the trigger, turn adjusting cap one quarter turn in a clockwise direction. Squeeze the trigger and read the pressure. Repeat this process until the desired system pressure is reached. Thread locking nut up to adjusting cap.

**Note:** Pressure is not set at the factory.

## SERVICE

The unloader should be serviced on the same schedule as the seals in the pump. Refer to SF Plunger Pump Service Manual for start-up, servicing of seals and valves, torque requirements, diagnosis and maintenance chart.