

This drawing remains our property. Its use without due authority is forbidden and will lead to legal action

NUT

Mechanical properties according to ISO 898-2
 Thread tolerance class: Coarse thread, 6H
 Property class 10

WASHER

Material: EN 1.7182 or equivalent alloy
 Hardness ≥ 465 HV1

ASSEMBLED NUT

Weight: 48 g/piece
 Coating: ZnNi8/An/T2, ISO 4042
 Corrosion resistance: min 600h Neutral salt spray test according to ISO 9227

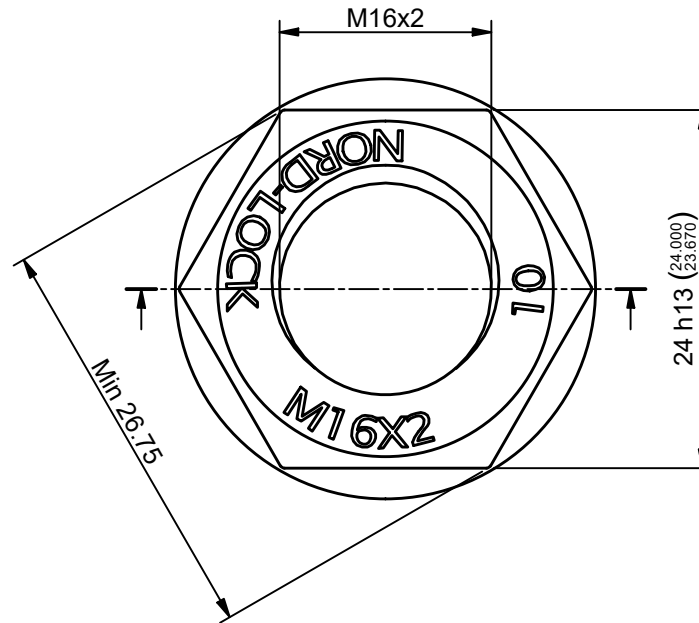
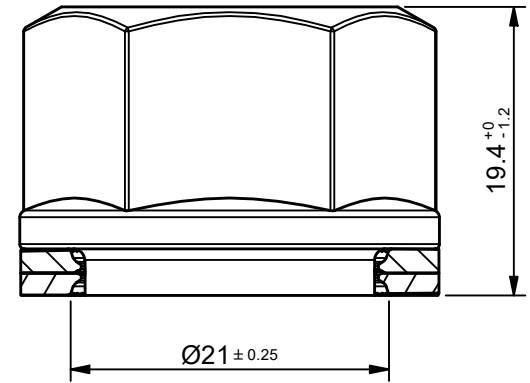
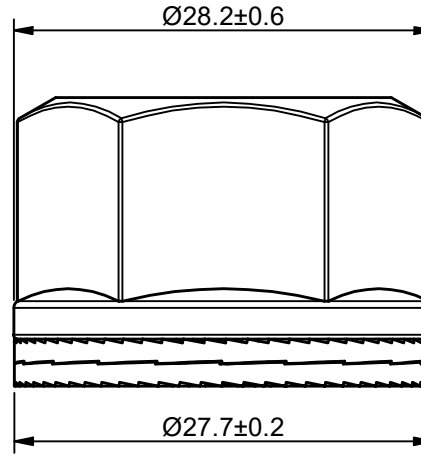
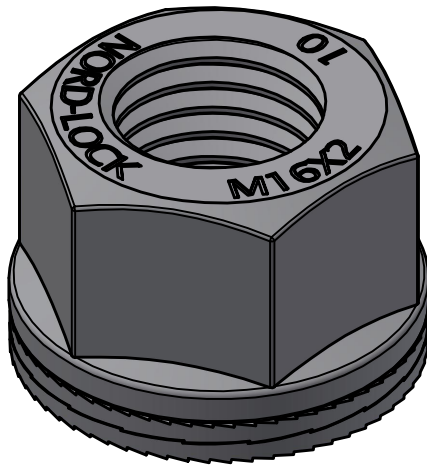

Designed by SANNANDE	Date 2020-06-10	General Tolerance	Article Number 3427	Placement 	Scale 2 : 1
 Bolt securing systems			Title NLCN M16x2		
			Drawing Number 10017702	Format A4	Revision C