

# Acuvim II

Advanced Power & Energy  
Meter Datasheet

ACCUENERGY



## DESCRIPTION

The Acuvim II Series advanced power and energy meter is a robust solution for power monitoring, kWh metering, power quality analysis, and more. This multifunction meter is engineered for easy integration into any project environment and is compatible with a wide array of plug-in expansion modules to facilitate communication on over 15 different industry-standard protocols. Its two available form factors include a panel mount meter with a digital display and a DIN rail transducer configuration. With IEC 61000-4-30 Class S compliant power quality analysis, Acuvim IIW can monitor key PQ events such as harmonics, voltage swells and more.

## FEATURES

- NEW** Revenue Grade: ANSI C12.20 class 0.1 & IEC 62053-22 class 0.1s.
- NEW** 4th CT input to measure neutral current.
- NEW** Dual Ethernet ports with both RSTP bridge daisy-chain mode and separately configurable network.
- NEW** High-resolution frequency measurement utilizes a custom moving average filter with 0.001Hz and 10mHz accuracy. Window size ranges from 1 - 50 cycles, and update rate varies from 1 - 2 cycles.
- + Data logging available with 8MB onboard memory and expandable to 8GB with WEB2 module.
- NEW** IEC 61000-4-30 Class S compliant power quality event measurements for Acuvim IIW.
- NEW** High-speed update rate. Fast Read mode offers a 20ms Modbus refresh rate, Fast Log is available at 100ms and 50ms intervals via Modbus RTU and TCP/IP.
- + Compatible with multiple CT output options including 5A mA, Accuenergy Rogowski coil, or 333mV.
- + Modbus-RTU & BACnet MS/TP ready. Optional modules add support for multiple industrial protocols & interfaces such as Modbus-TCP/IP, BACnet-IP, IEC 61850 2nd Ed., Wi-Fi, & EtherNet/IP.

## KEY FEATURES

### Communication

- + Modbus RTU protocol and BACnet MS/TP via RS485
- + Wi-Fi and Ethernet Communication Channels (Modbus TCP, BACnet IP, HTTP, SMTP, SNTP, HTTPs, Post, FTP, PROFINET)
- + Dual RJ45 ports with RSTP daisy-chain and two individually configurable Ethernet ports

### Data Logging

- + Acuvim II meters offer three assignable historical logs and a real-time clock to record many metering parameters with accurate timestamping. Add the AXM WEB2 module to expand the memory to 8GB with an adjustable log size.
- + WEB2 module offers additional granularity to data logging such as 1 second interval timing and max/min/average and instantaneous reading for real time parameters.

### Fast Response

- + 512 samples per cycle for measurement, 100ms and 20ms Modbus refresh rate, and 100ms and 50ms options Fast Logging for real time parameters including Frequency and Active Power.

### Flexible Current Transformer Options

- + The Acuvim II is directly compatible with Rogowski coils plus a variety of other current transformer outputs, including 5A, 1A, 80mA, 100mA, 200mA, and 333mV. All CTs are available from Accuenergy.

### Power Quality Measurements

- + Acuvim IIW offers IEC 61000-4-30 Class S compliant power quality event measurements. It is designed for monitoring and diagnosing power quality issues to improve efficiency and reliability, and enhance overall system performance. Perfect for energy management systems, building automation systems, and more.

### Time of Use

- + Users can assign up to four tariffs (sharp, peak, valley, & normal) to different time periods within a day. The Acuvim II meter will calculate and accumulate energy to different tariffs according to the meter's internal clock and TOU settings.

### Optional I/O Module

- + Expand Acuvim II I/O functionality by connecting an optional I/O module. A maximum of three modules can be used per meter. Digital input, digital output, pulse output, relay output, analog input, and analogue output I/O modules are available.

### Alarms

- + Limits can be set for up to 16 indicated parameters with a specified time interval. Parameters that are over or under the setting limit and persist longer than the specified time interval will be recorded and trigger the Alarm DO. Choose from 80 available parameters.



## APPLICATIONS

- + Submetering
- + Energy Storage, Microgrids, and VPPs
- + Power Generation
- + Load Banks
- + Building Automation
- + PDUs and Data Centers
- + Energy Management Systems
- + Substation and Distribution Systems
- + Transformer Monitoring
- + Measurement & Verification

## SPECIFICATIONS

### Metering

PARAMETERS		ACCURACY	RESOLUTION	RANGE
Voltage		0.1%	0.1V	10V~1000kV
Current		0.1%	0.1mA	5mA~50000A
Power		0.1%	1W	-9999MW~9999MW
Reactive Power		0.1%	1var	-9999Mvar~9999Mvar
Apparent Power		0.1%	1VA	0~9999MVA
Power Demand		0.1%	1W	-9999MW~9999MW
Reactive Power Demand		0.1%	1var	-9999Mvar~9999Mvar
Apparent Power Demand		0.1%	1VA	0~9999MVA
Power Factor		0.1%	0.001	-1.000~1.000
Frequency		0.001%	0.001Hz	45.00~65.00Hz
Energy	Primary 0.1	0.1%	0.1kWh	0-99999999.9kWh
	Primary 0.001	0.1%	0.001kWh	0-999999.999kWh
	Secondary	0.1%	0.001kWh	0-999999.999kWh
Reactive Energy	Primary 0.1	0.1%	0.1kvarh	0-99999999.9kvarh
	Primary 0.001	0.1%	0.001kvarh	0-999999.999kvarh
	Secondary	0.1%	0.001kvarh	0-999999.999kvarh
Apparent Energy	Primary 0.1	0.1%	0.1kVAh	0-99999999.9kVAh
	Primary 0.001	0.1%	0.001kVAh	0-999999.999kVAh
	Secondary	0.1%	0.001kVAh	0-999999.999kVAh
Harmonics		1.0%	0.10%	
Phase Angle		2.0%	0.1°	0.0°~359.9°
Unbalance Factor		2.0%	0.10%	0.0%~100.0%
Running Time			0.01h	0~9999999.99h

### Input

#### CURRENT INPUTS (EACH CHANNEL)

Nominal Current Options	① 5A, ② 1A, ③ 333mV, ④ Rogowski Coil, ⑤ 80mA/100mA/200mA
Metering Range	① 0-10A, ② 0-2A, ③ 0-400mV, ④ 0-400mV, ⑤ 0-240mA
Pickup Current	① 5mA, ② 1mA, ③ 0.25mV, ④ 0.25mV, ⑤ 0.15mA
Withstand	20Arms Continuous, 0.1% of Nominal 100Arms for 1 Second, Non-Recurring
Burden	0.05VA (Typical) @ 5A RMS
Accuracy	0.1% at Reading

#### VOLTAGE INPUTS (EACH CHANNEL)

Nominal Full Scale	480Vac L-N, 828Vac L-L
Withstand	1500Vac Continuous 2500Vac, 50/60Hz for 1 Minute
Input Impedance	2MΩ per Phase
Metering Frequency	45Hz~65Hz
Pickup Voltage	10Vac
Accuracy	0.1% at Reading

#### ENERGY ACCURACY

Active	Class 0.1s (According to IEC 62053-22) Class 0.1 (According to ANSI C12.20)
Reactive	Class 0.5s (According to IEC 62053-24)

#### HARMONIC RESOLUTION

Metered Value	63 <sup>rd</sup> Harmonic
---------------	---------------------------

### Communication

<b>Modbus-RTU or BACnet MS/TP</b>	Modbus-RTU 2-Wire Shielded Twisted Pair Cable Connection 2400~115200 bps
<b>SECOND RS-485 PORT (OPTIONAL MODULE)</b>	Same as the Primary RS485 port Baud Rate: 4800~38400 bps
<b>ETHERNET (OPTIONAL MODULE)</b>	Ethernet 10M/100M BaseT MODBUS-TCP/IP DNP 3.0 V2 Over IP Level 2 IEC 61850 2nd Ed. SNMP V3 BACnet-IP HTTP/HTTPs Webserver HTTP/HTTPs, FTP data post SMTP MQTT MV90 NTP PROFINET

## SPECIFICATIONS

### I/O Options

#### DIGITAL INPUT

Input Type	Dry
Input Resistance	100kΩ
Input Voltage Range	20~160 Vac/dc
Input Current (Max)	2mA
Start Voltage	15V
Stop Voltage	5V
Pulse Frequency (Max)	100Hz, 50% Duty Ratio (5ms ON and 5ms OFF)
SOE Resolution	2ms

#### DIGITAL OUTPUT (DO) (PHOTO-MOS)

Voltage Range	0~250Vac/dc
Load Current	100mA (Max)
Output Frequency	25Hz, 50% Duty Ratio (20ms ON, 20ms OFF)
Isolation Voltage	2500Vac

#### RELAY OUTPUT (RO) (NO, Form A)

Switching Voltage (Max)	250Vac, 30Vdc
Load Current	5A (R), 2A (L)
Set Time	10ms (Max)
Contact Resistance	30mΩ (Max)
Isolation Voltage	2500Vac
Mechanical Life	1.5x10 <sup>7</sup>

#### ANALOG OUTPUT (AO)

Output Range	0~5V, 0~20mA 1~5V, 4~20mA Optional
Accuracy	0.50%
Temperature Drift	50ppm/°C Typical
Isolation Voltage	500Vdc
Open Circuit Voltage	15V

#### ANALOG INPUT (AI)

Input Range	0~5V, 0~20mA 1~5V, 4~20mA Optional
Accuracy	0.20%
Temperature Drift	50ppm/°C Typical
Isolation Voltage	500Vdc

#### POWER SUPPLY FOR DI (24 VDC)

Output Voltage	24Vdc
Output Current	42mA
Load (Max)	21 DI's

### Control Power

Universal	AC or DC
<b>AC/DC CONTROL POWER</b>	
Operating Range	100~415Vac, 50/60Hz; 100~300Vdc
Burden	5W
Frequency	50/60Hz
Withstand	3250Vac, 50/60Hz for 1 Minute
	Installation Category III (Distribution)

#### LOW VOLTAGE DC CONTROL POWER (P2V3 Option Only)

Operating Range	20~60Vdc
Burden	5W

### Operating Environment

Operating Temperature	-25°C to 70°C -13°F to 158°F
Storage Temperature	-40°C to 85°C -40°F to 176°F
Relative Humidity	5% to 95% Non-Condensing

### Standard Compliance & Certifications

Measurement Standard	IEC 62053-22; ANSI C12.20; IEC61557-12
Environmental Standard	IEC 60068-2, CE, RoHS
Safety Standard	IEC 61010-1, UL 61010-1
EMC Standard	IEC 61000-4/-2-3-4-5-6-8-11, CISPR 22, IEC 61000-3-2, IEC 61000-6-2/4, EN55011
Outlines Standard	DIN 43700, ANSI C39.1
Protocol Conformance	IEC 61850 2nd Ed. BTL Listed for B-SA

# FUNCTION LIST

● Function; ○ Option; Blank NA

REAL TIME MEASURING	Parameters	Acuvim IIR	Acuvim IIW
Phase Voltage	V1, V2, V3, Vlnavg	●	●
Line Voltage	V12, V23, V31, Vllavg	●	●
Current	I1, I2, I3, In, Iavg	●	●
Power	P1, P2, P3, Psum	●	●
Reactive Power	Q1, Q2, Q3, Qsum	●	●
Apparent Power	S1, S2, S3, Ssum	●	●
Power Factor	PF1, PF2, PF3, PF	●	●
Frequency	F	●	●
Load Features	L/C/R	●	●
Four Quadrant Powers	Four Quadrant Powers	●	●
<b>4-30 CLASS S READINGS</b>			
10/12 Cycle 150/180 Cycle 10 Minutes 2 Hours	F,V1,V2,V3,Vlnavg, V12,V23,V31,Vllavg, I1,I2,I3,In,Iavg, THD_V, THD_I, Unbalance Factor Sequence Readings Current Harmonic Amplitude Voltage Harmonic Amplitude		●
<b>INDEPENDENT CHANNEL</b>			
System Phase Voltage	V1, V2, V3, Vlnavg	●	●
System Line Voltage	V12, V23, V31, Vllavg	●	●
System Frequency	F	●	●
Current	Ichannel1, Ichannel2, Ichannel3, Ichannel4, Isum_1avg, Isum_2avg	●	●
Power	Pchannel1, Pchannel2, Pchannel3, Pchannel4, Psum_1, Psum_2	●	●
Reactive Power	Qchannel1, Qchannel2, Qchannel3, Qchannel4, Qsum_1, Qsum_2	●	●
Apparent Power	Schannel1, Schannel2, Schannel3, Schannel4, Ssum_1, Ssum_2	●	●
Power Factor	PFchannel1, PFchannel2, PFchannel3, PFchannel4, PFsum_1, PFsum_2	●	●
Load Features	Load Features	●	●
Four Quadrant Powers	Four Quadrant Powers	●	●
Energy	Epchannel1_imp, Epchannel2_imp, Epchannel3_imp, Epchannel4_imp Epchannel1_exp, Epchannel2_exp, Epchannel3_exp, Epchannel4_exp Epsum1_imp, Epsum2_imp, Epsum1_exp, Epsum2_exp Epsum1_Totoal, Epsum2_Total, Epsum1_Net, Epsum2_Net	●	●
Reactive Energy	Eqchannel1_imp, Eqchannel2_imp, Eqchannel3_imp, Eqchannel4_imp, Eqchannel1_exp, Eqchannel2_exp, Eqchannel3_exp, Eqchannel4_exp, Eqsum1_imp, Eqsum2_imp, Eqsum1_exp, Eqsum2_exp, Eqsum1_Total, Eqsum2_Total, Eqsum1_Net, Eqsum2_Net	●	●
Apparent Energy	Eschannel1, Eschannel2, Eschannel3, Eschannel4, Essum1, Essum2	●	●
Demand	Dmd_Pchannel1, Dmd_Pchannel2, Dmd_Pchannel3, Dmd_Pchannel4, Dmd_Qchannel1, Dmd_Qchannel2, Dmd_Qchannel3, Dmd_Qchannel4, Dmd_Schannel1, Dmd_Schannel2, Dmd_Schannel3, Dmd_Schannel4, Dmd_Psum1, Dmd_Psum2, Dmd_Qsum1, Dmd_Qsum2 Dmd_Ssum1, Dmd_Ssum2, Dmd_Ichannel1, Dmd_Ichannel2, Dmd_Ichannel3, Dmd_Ichannel4	●	●
<b>ENERGY</b>			
Active Energy	Ep_imp, Ep_exp, Ep_total, Ep_net, Epa_imp, Epa_exp, Epb_imp, Epb_exp, Epc_imp, Epc_exp, Ep_q1, Ep_q2, Ep_q3, Ep_q4	●	●
Reactive Energy	Eq_imp, Eq_exp, Eq_total, Eq_net, Eqa_imp, Eqa_exp, Eqb_imp, Eqb_exp, Eqc_imp, Eqc_exp	●	●
Apparent Energy	Es_imp, Es_exp, Es_total, Es_net, Esa, Esb, Esc, Es_q1, Es_q2, Es_q3, Es_q4	●	●
<b>DUAL SOURCE ENERGY</b>			
Energy to Generator	Energy1_Generator, Energy2_Generator, Energy3_Generator	●	●
Energy to Grid	Energy1_Grid, Energy2_Grid, Energy3_Grid	●	●

# FUNCTION LIST





● Function; ○ Option; Blank NA

DEMAND		
Current Demand	Dmd_I1, Dmd_I2, Dmd_I3, Dmd_In	● ●
Power Demand	Dmd_Psum, Dmd_Qsum, Dmd_Ssum	● ●
TIME		
Real-Time Clock	Year, Month, Day, Hour, Minute, Second	● ●
HOUR		
Meter Running Time	Hour	● ●
Load Running Time	Hour	● ●
POWER QUALITY		
Voltage Unbalance	U_unbl	● ●
Current Unbalance	I_unbl	● ●
Voltage THD	THD_V1, THD_V2, THD_V3, THD_Vavg	● ●
Current THD	THD_I1, THD_I2, THD_I3, THD_Iavg	● ●
Individual Harmonics	Harmonics 2nd to 63rd (50Hz or 60Hz)	● ●
Voltage Crest Factor	Crest Factor	● ●
TIF	THFF	● ●
Current K Factor	K Factor	● ●
SEQUENCE		
Voltage/Current Sequence	Positive Sequence, Negative Sequence, Zero Sequence	● ●
Phase Order	ABC, ACB	● ●
PHASE ANGLES		
Voltage/Current Phase Angles	Voltage Phase Angle, Current Phase Angle	● ●
STATISTICS		
MAX with Time Stamp MIN with Time Stamp	Each Phase of V & I, Total of P, Q, S, PF & F, Demand of I1, I2, I3, IN, P, Q, & S, Each Phase THD of V & I, Unbalance Factor of V & I	● ●
ALARM		
Over/Under Limit Alarm	V, I, P, Q, S, PF, V_THD & I_THD Each Phase and Total/Average, Unbalance Factor of V & I, Load Type, Analog and Digital Input of Each Channel, Demand of I1, I2, I3, P, Q & S, Reverse Phase Sequence	● ●
WAVEFORM CAPTURE		
Voltage and Current Waveform	Trigger, Manual, DI change, Voltage Sag Voltage Swell Current Swell	●
4-30 CLASS S WAVEFORM CAPTURE		
Class S Voltage and Current Waveform	Trigger, Manual, DI Change, Voltage Sag Voltage Swell Voltage Interrupt Current Swell	●
POWER QUALITY EVENT LOGGING		
Power Quality Event with Time Stamp	Voltage SAG and Fail, Current overflow, Phase Sequence Error	●



<b>4-30 CLASS S PQ EVENT</b>				
Class S Power Quality Event with Timestamp and Duration	Voltage Sag Voltage Swell Voltage Interrupt Unbalance Voltage Current Swell Unbalance Current Event Duration			●
<b>DATA LOGGING</b>				
Data Logging 1 Data Logging 2 Data Logging 3 Data Logging 4	Frequency V1, V2, V3, Vlnavg V12, V23, V31, Vllavg I1, I2, I3, In, Iavg P1, P2, P3, Psum Q1, Q2, Q3, Qsum S1, S2, S3, Ssum Ep_imp, Ep_exp, Ep_total, Ep_net, Eq_imp, Eq_exp, Eq_total, Eq_net, Es_imp, Es_exp, Es_total, Es_net Epa_imp, Epa_exp, Epb_imp, Epb_exp, Epc_imp, Epc_exp Eq_a_imp, Eq_a_exp, Eq_b_imp, Eq_b_exp, Eq_c_imp, Eq_c_exp Esa_imp, Esa_exp, Esb_imp, Esb_exp, Esc_imp, Esc_exp PF1, PF2, PF3, PF U_unbl, I_unbl Load Type THD_V1, THD_V2, THD_V3, THD_Vavg THD_I1, THD_I2, THD_I3, THD_Iavg Harmonics 2nd to 63rd, Crest Factor, THFF, K Factor Sequence, phase angles DI counter, AI, AO Dmd P, Dmd Q, Dmd S, Dmd_I1, Dmd_I2, Dmd_I3		●	●
<b>TIME OF USE</b>				
Energy/Max Demand	TOU, 4 Tariffs, 12 Seasons, 14 Schedules		●	●
Daylight Saving Time	Two Adjustable Formats		●	●
<b>I/O MODULE</b>				
Switch Status (DI)	Digital Input		○	○
Power Supply for DI	24V DC		○	○
Relay Output (RO)	NO, Form A		○	○
Digital Output (DO)	Photo-MOS		○	○
Pulse Output (PO)	By Using DO		○	○
Analog Input (AI)	0 (4) – 20mA, 0 (1) – 5V		○	○
Analog Output (AO)	0 (4) – 20mA, 0 (1) – 5V		○	○
<b>COMMUNICATION</b>				
RS485 Port, Half Duplex, Optical Isolated	Modbus-RTU/BACnet Protocol		●	●
Ethernet Module	Modbus-TCP, HTTP, SMTP, SNMP, Modbus Gateway Passthrough		○	○
RS-485 Module	Modbus-RTU Protocol		○	○
<b>ONBOARD MEMORY SIZE</b>				
Memory	Bytes	8MB		16MB (8MB Data Logging + 8MB Power Quality)
<b>DISPLAY</b>				
LCD or DIN Rail			○	○
<b>DIMENSIONS</b>				
96×96×64.3mm (Opening Size: 92 × 92mm)				

## COMMUNICATION MODULES

● Function; ⊕ Option; Blank NA

	Standard	AXM WEB2 FOLC	AXM WEB2	AXM WEB2-D	AXM RS485
					
Modbus-RTU	●				●
BACnet-MS/TP	●				
DNP 3.0 V2 Over IP		●	●	●	
IEC 61850 2nd Ed.		●	●	●	
Modbus-TCP/IP		●	●	●	
HTTP/HTTPS Webserver		●	●	●	
SMTP Email		●	●	●	
SNMP V3		●	●	●	
NTP Synchronization		●	●	●	
EtherNet/IP		●	●	●	
MQTT		●	●	●	
RSTP		●	●	●	
IPv6		●	●	●	
HTTP/HTTps Push		●	●	●	
FTP Post		●	●	●	
sFTP Server		●	●	●	
Datalogging	8MB	8GB	8GB	8GB	
BACnet-IP		●	●	●	
PROFINET		●	●	●	
Wi-Fi		●	●	●	
RJ45 Ports		1	2	2	
Fiber Optics LC		●			

## IO MODULES

	AXM-IO1	AXM-IO2	AXM-IO3
			
Digital Input (Dry)	6	4	4
Digital Output		2	
Relay Output	2		2
Analogue Inputs			2
Analogue Outputs		2	
Power Supply	24Vdc		

## DIMENSIONS

### Acuvim II Dimensions

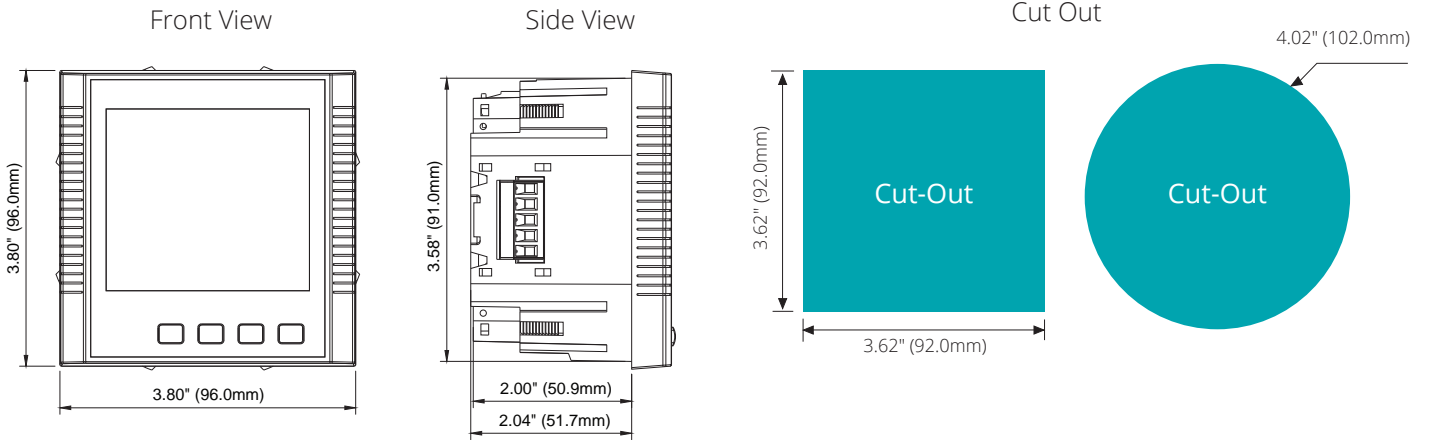

### DIN Mount Meter Dimensions

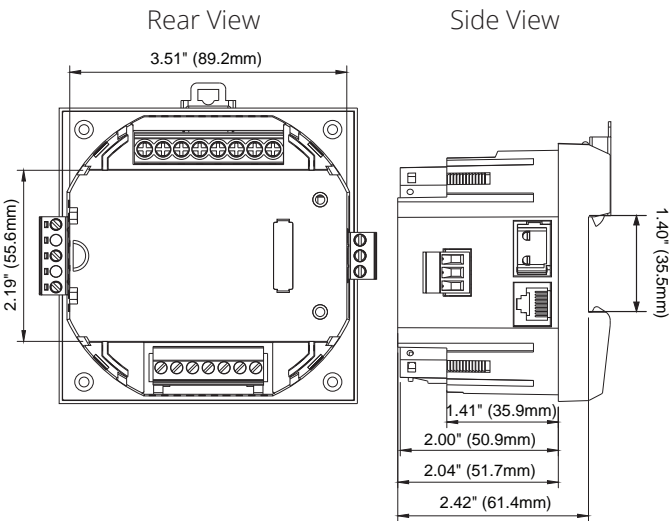

### External Display Module Dimensions

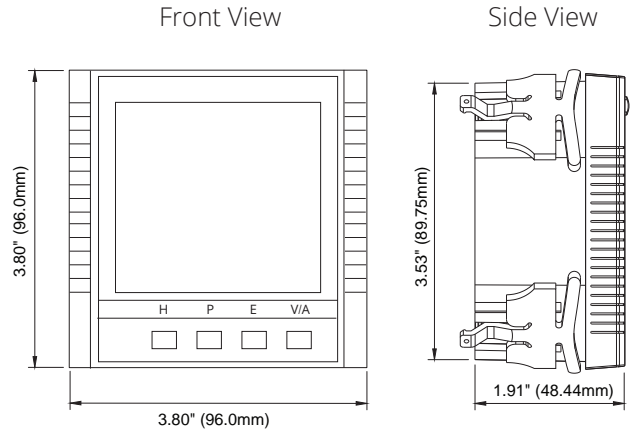

- Note: 1. Display module is connected with a six-foot 10 pin RJ50 cable. If longer cable is needed, please specify that in the ordering statement.
2. Display module opening size and Acuvim II body openings are exactly the same size.

### I/O Module Dimensions

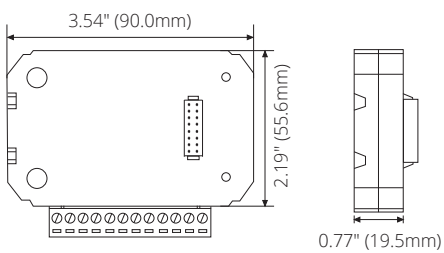

### Communication Module Dimensions

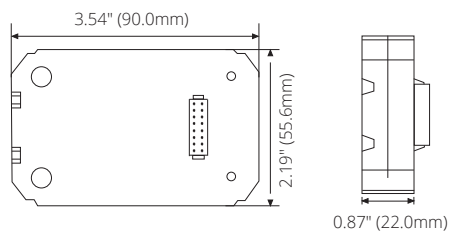

# WIRING DIAGRAMS

## Typical Wiring With 5A/1A CTs

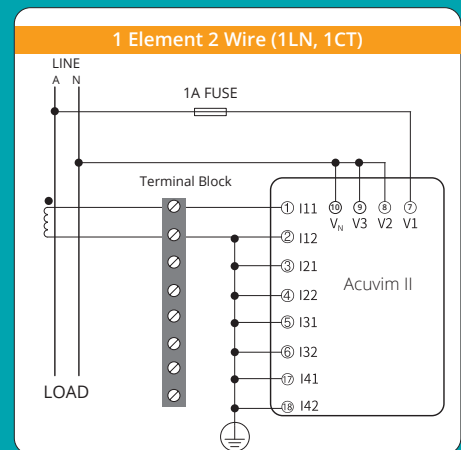
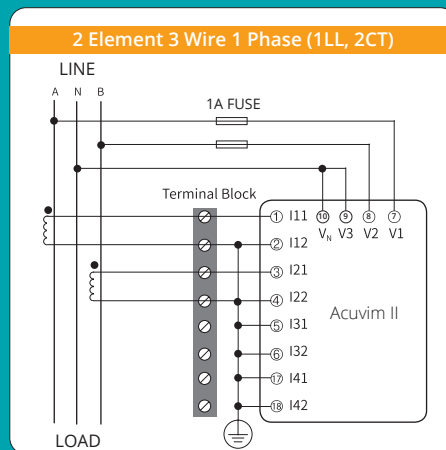
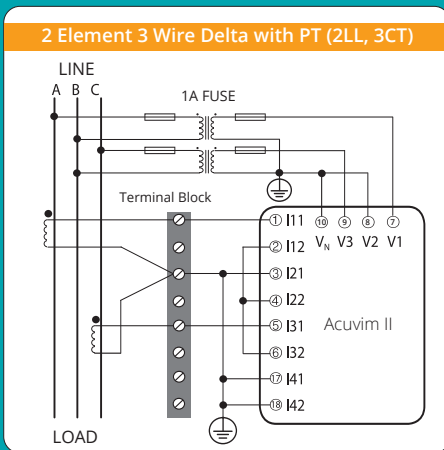
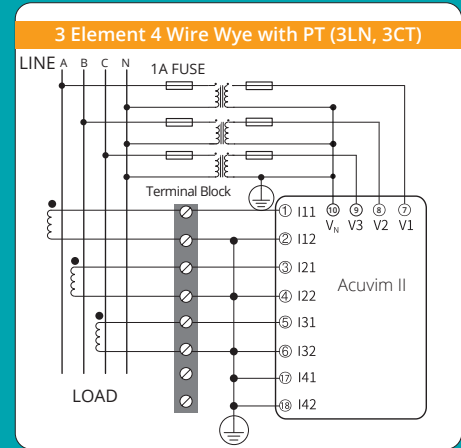
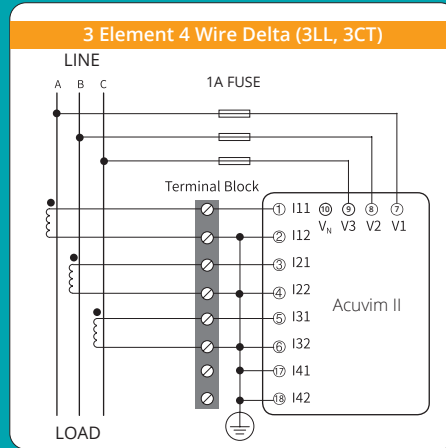
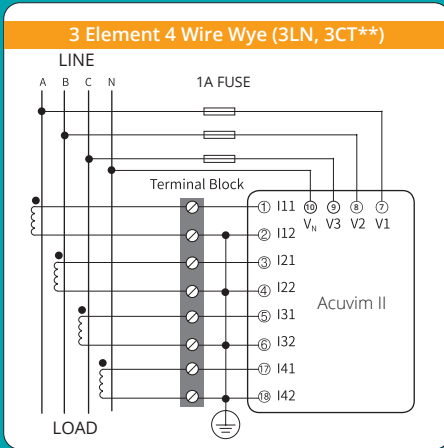

## I/O Module Wiring

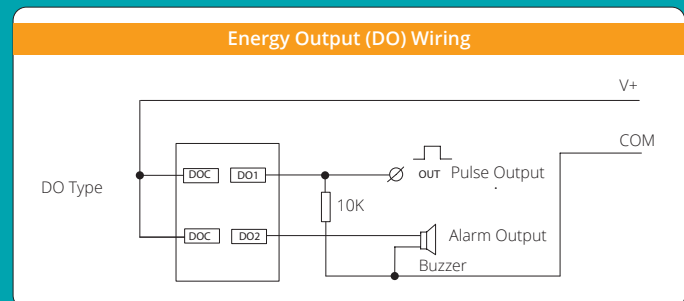
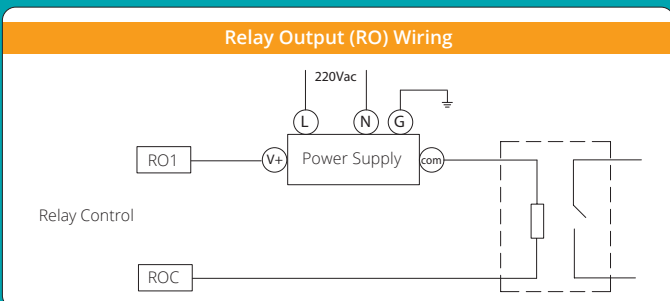
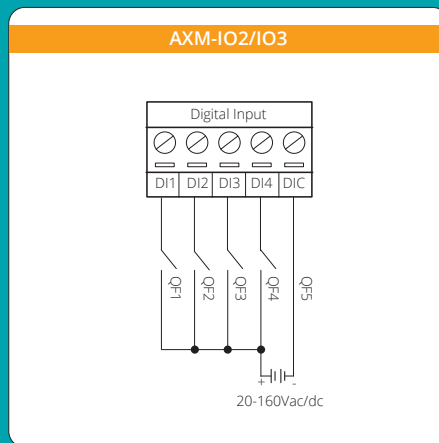
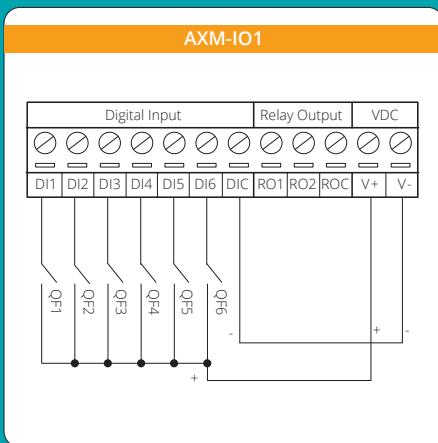

Note: \*2CT configuration is optional only in 3 Phase 3 Wire system.  
 \*\*Neutral CT is optional.

## WIRING DIAGRAMS

### Typical Wiring RCT/mV/mA Current Input

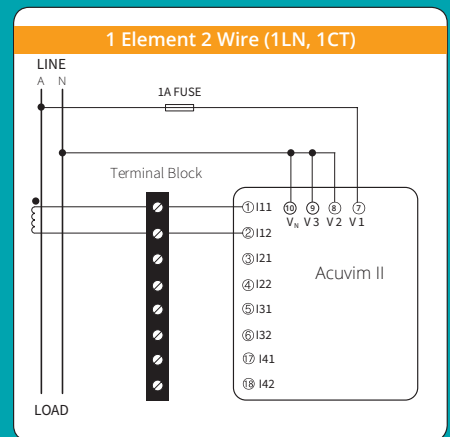
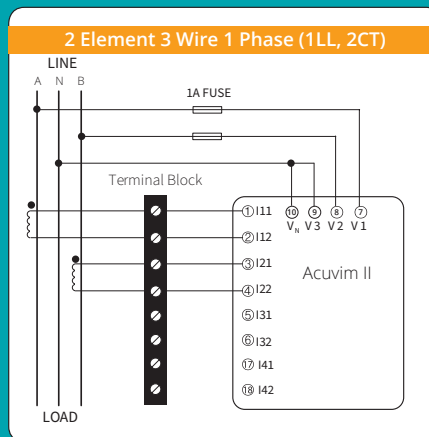
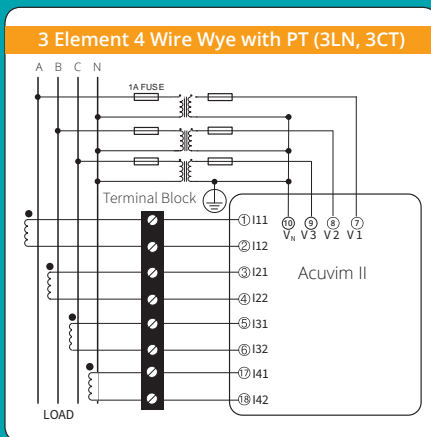
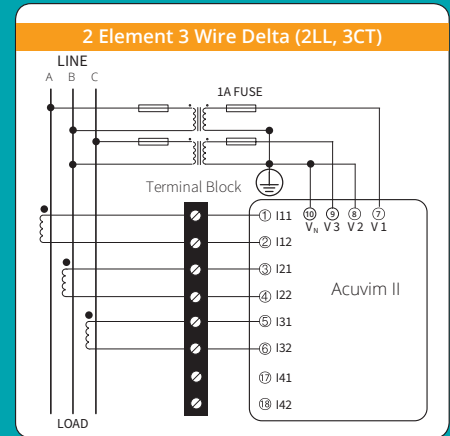
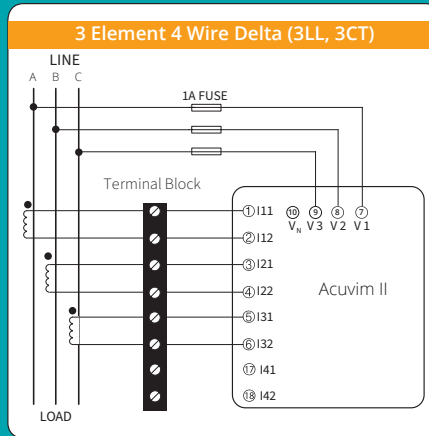
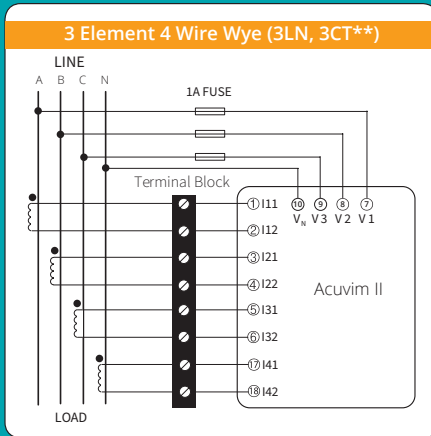

Note: \*2CT configuration is optional only in 3 Phase 3 Wire system.  
 \*\*Neutral CT is optional.

## ACCESSORIES

### DIN Rail Adapter

The AXM-DIN Rail Adapter is the easy way to mount the Acuvim II Series energy meter on either horizontal or vertical DIN rail. The adapter quickly secures to the meter and is compatible with all AXM communication modules as well as I/O options.



### Protective Display Cover

The Protective Display Cover is designed for Acuvim II Series energy meters and other 96mm by 96mm display panel meters. Crucial in harsh environments, it increases the IP environmental rating of the meter's display to IP66 or NEMA 4X.



### USB RS485 Converter

This plug-and-play USB to Serial RS485 Converter is designed to provide a convenient, reliable USB connection to the Acuvim II Series power meters and other serial devices.



## ORDERING INFORMATION

+ Meter Model	- Mounting Option	- Current Input	- Power Supply
<b>Acuvim IIR:</b> Data logging, TOU	<b>D:</b> LCD Display (Panel Mount Meter/Transducer)	<b>5A:</b> 5A/1A (Input Field Selectable)	<b>P1V3:</b> 100~415Vac, 50/60Hz, 100~300Vdc
<b>Acuvim IIW:</b> IIR + Waveform Capture and PQ Event Logging	<b>M:</b> DIN-Rail Mount Transducer without Display (Optional Remote Display Available)	<b>mV:</b> 333mV and Rogowski Coil (Input Field Selectable)	<b>P2V3:</b> 20~60Vdc
		<b>mA:</b> 80mA/100mA/200mA (Input Field Selectable)	

<b>Ordering Example:</b>	<b>Acuvim-IIR-M-mV-P2V3</b>
	<b>Acuvim-IIW-D-5A-P1V3</b>

- Note:**
1. Accuenergy suggests using a USB-RS485 converter for configuration, and 3 CTs per three phase circuits.
  2. All fields must be completed to create a part number.
  3. Add "S" after power supply for anti-tampering seal option.

+ Communication Module (Optional)	- Protocols
<b>AXM</b>	<b>WEB2-FOLC:</b> IEC 61850 2nd Ed., Modbus-TCP, HTTP/HTTps Webserver, SMTP Email, SNMP, HTTP/HTTps Push, FTP Post, sFTP Server, BACnet-IP, Datalogging, Wi-Fi, Fiber Optics LC, Ethernet port, EtherNet/IP, MQTT, Modbus Gateway Passthrough, PROFINET
	<b>WEB2:</b> IEC 61850 2nd Ed., Modbus-TCP, HTTP/HTTps Webserver, SMTP Email, SNMP, HTTP/HTTps Push, FTP Post, sFTP Server, BACnet-IP, Datalogging, Wi-Fi, Dual Ethernet Ports, EtherNet/IP, MQTT, Modbus Gateway Passthrough, PROFINET
	<b>WEB2-D:</b> IEC 61850 2nd Ed., Modbus-TCP, HTTP/HTTps Webserver, SMTP Email, SNMP, HTTP/HTTps Push, FTP Post, sFTP Server, BACnet-IP, Datalogging, Dual Ethernet Ports, EtherNet/IP, MQTT, Modbus Gateway Passthrough, PROFINET
	<b>RS485:</b> Modbus-RTU

<b>Ordering Example:</b>	<b>AXM-RS485</b>
	<b>AXM-WEB2-FOLC</b>

+ I/O Module (Optional)	
<b>AXM-IO1</b>	6 Digital Inputs, 2 Relay Outputs, 24Vdc Power Supply
<b>AXM-IO2</b>	4 Digital Inputs, 2 Digital Outputs, 2 Analog Outputs (0~5V or 1~5V, 0~20mA or 4~20mA)
<b>AXM-IO3</b>	4 Digital Inputs, 2 Relay Outputs, 2 Analog Inputs (0~5V or 1~5V, 0~20mA or 4~20mA)

<b>Ordering Example:</b>	<b>AXM-IO1</b>
--------------------------	----------------

+ Accessories (Optional)	
<b>REM-DS2:</b>	Remote Display (Only for Acuvim II DIN-Rail Mount "M" option)
<b>AXM-DIN:</b>	DIN Rail Adapter
<b>IP66/NEMA4X:</b>	Environmental Protection Cover
<b>USB-RS485:</b>	USB-to-RS485 Converter

- Note:**
1. Refer to the Communication table and I/O Module table.
  2. A maximum of 3 modules may be attached to the meter. If a communication module is used (e.g. AXM-WEB2), it must be installed on the back FIRST before the other I/O modules are attached.
  3. No more than 2 of the same I/O modules may be attached to the meter (e.g. two AXM-IO2). The same two I/O modules must have different logic numbers. Logic numbers can be configured as either 1 or 2 through Acuvim 2 or AXM-WEB2.
  4. If Acuvim IIW uses DI to trigger a waveform capture, the I/O module logic number must be Module 1.



### Accuenergy Inc.

Los Angeles - Toronto - Pretoria  
 North America Toll Free: 1-877-721-8908  
 Web: [www.accuenergy.com](http://www.accuenergy.com)  
 Email: [marketing@accuenergy.com](mailto:marketing@accuenergy.com)

Revision Date: March 2026 Version: 2.0.17  
 Specs Subject To Change Without Notice.



ISO 9001, 14001  
& 45001 Certified



ISO 27001 &  
50001 Certified

