

HSG screw jack (cubic design)

INKOMA - GROUP

INKOMA-GROUP



INKOMA-GROUP Headoffice
Sitz der INKOMA Maschinenbau GmbH
Neue Reihe 44
D - 38162 Schandelah - Germany

phone: +49/(0)5306-9221-0
fax: +49/(0)5306-9221-50
e-mail: info@inkoma.de
internet: www.INKOMA-GROUP.com

We reserve the right to make technical changes.
2014-1-MP-OE-e © INKOMA-GROUP

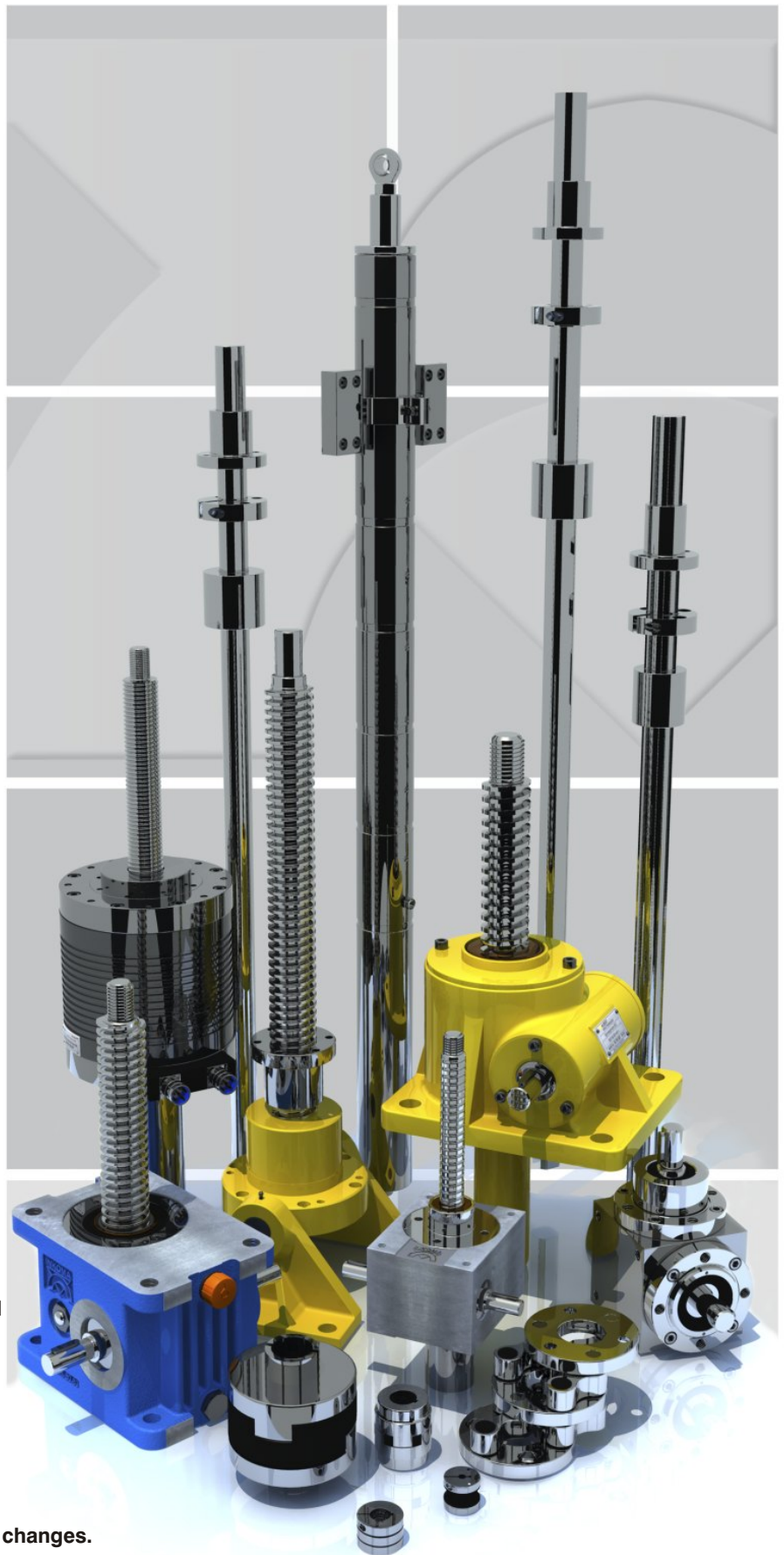

HSG screw jack (cubic design)

Product description

Precision screw jack HSG lifting force 2.5 kN to 500 kN

INKOMA-precision screw jacks are high quality engineering products for precise lifting, lowering and pivoting of loads, and are, under normal operation, maintenance free. The use of high quality grey cast iron and aluminium in the production of the housings guarantees a long life and a high operating margin. All housings have a cubic form and are machined on all faces.

Motor and screw jack assemblies may be mounted in any attitude. Compressive, tensile and offset loadings can be tolerated even under extreme operating conditions. The worm gearing in the INKOMA-precision screw jacks has a special gear form. A concave profile and cylindrical worm with an enveloping wheel results in low specific tooth pressure giving a long working life. The worm gear is manufactured from quality alloy steel and is ground and ion-nitrided. Sealed angular contact ball bearings on both ends of the worm shaft carry the resultant axial loads from the drive. The gearing, the gear module and the helix angle are optimised to allow transmission of the largest possible proportion of the nominal torque. The special worm wheel is produced from high performance bearing bronze. The precise location diameter and the use of ball thrust bearings accurately position the worm wheel.

Using a centrally guided threaded flanged nut in the gear housing and the cover, the worm gearset backlash can be adjusted to a very low level and locked in position. Above and below the worm wheel a bronze bush is located to carry the high reactive loads on the translating spindle.

Normally the gear ratios and the spindle pitch are matched. The trapezoidal spindle is a precision component rolled to tight tolerances. Single start rolled trapezoidal spindles are self locking, however it is recommended that an end-stop, motor brake or similar is employed in order to ensure that operational safety standards are met.

Precision screw jack with ball screw spindle
Precision screw jacks can be equipped with a range of ball screws (KGS). For versions see table. The use of ball screws allows higher lifting speeds. Higher efficiency (ca. 90%) reduces the required input power and increases the available duty.

Note: The maximum lifting capacity for each size is reduced. Please note the dynamic lifting force F_{dyn} [kN]. Screw jacks fitted with ball screws (KGS) are not self-locking. For this reason the motor must be fitted with a brake.

To ensure the most careful matching of your requirements we have developed a comprehensive range of accessories.

If you have questions or problems, regarding power, special designs, corrosion resistance, spindles or modified gear housings, contact our engineers and sales personnel. We are always ready to assist in the correct selection of our products and with the design of lifting systems. Please make use of our wide experience.

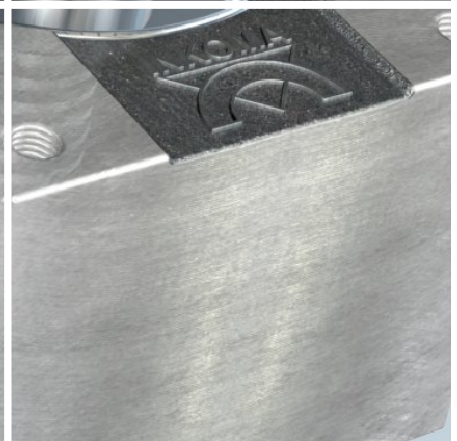
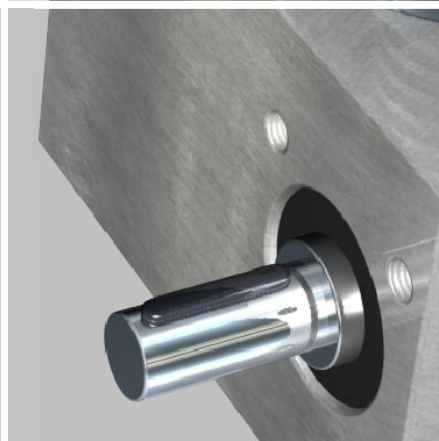
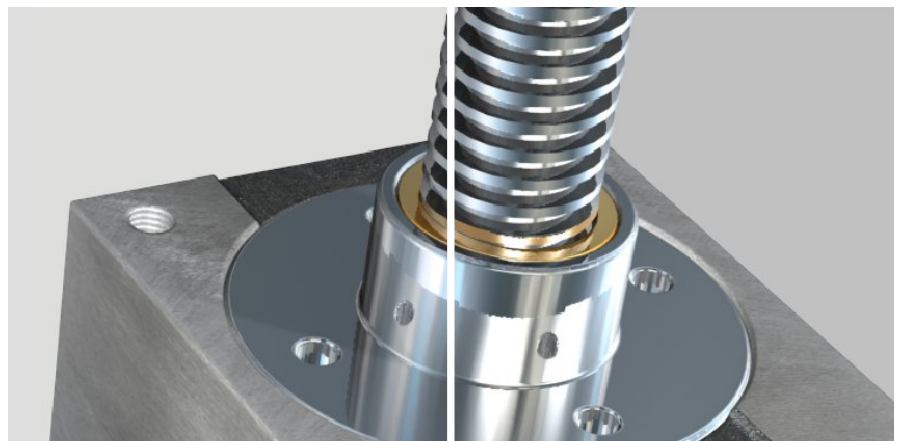
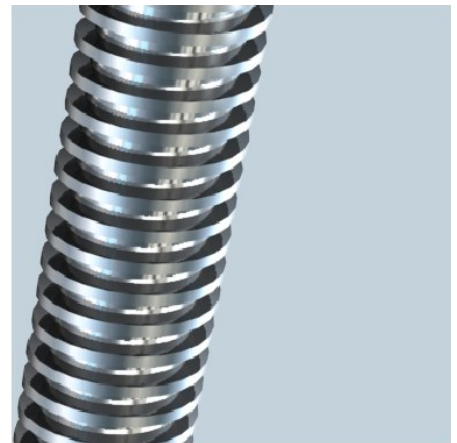

HSG screw jack (cubic design)

Accessories for rotating spindle version R

Page references

The comprehensive range of accessories for high capacity screw jacks type HSG allows the designer the flexibility to tailor the use of the screw jack precisely to the application. All accessories are manufactured to the same exacting standards as the rest of the INKOMA product range.

In addition to this comprehensive selection, customers special requirements can be accommodated.

Please consult our engineering staff.

Duplex nut - DFM

connection of two bellows adaption for lubrication
see page 194

Automatic lubrication device
allows continuous grease supply
see page 200

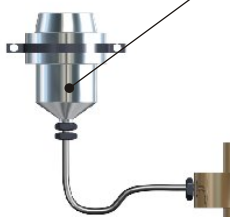

Safety nut - SFM

allows wear monitoring
see page 194



Mounting feet - BP

provides an alternative method
see page 210



Cardan shafts - GX/GE

provide torsionally stiff resilient connections
see page 222



Support bearings - SNH

to support extended cardan shafts
see page 224



Trunnion adaptor - KA/KAS

allows articulating fitting of flanged nut
see page 210



Bearing block/ flange - LB/LF

base mounting bearing unit for KA, KAS or SL
see page 214



Motor adaptor - MG

for positive and efficient
mounting of motors
see page 228



Elaflex coupling - EFK

flexible shaft coupling
see page 224

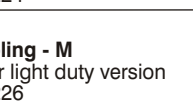

Gear coupling - M

standard or light duty version
see page 226



Bearing plate - GL

to support the free end of the spindle
see page 198

Flanged nut - FMS/FM

for standard applications
see page 192

Trapezoidal spindle nut - TM/ST

for applications where space is critical
see page 196

Self aligning nut flange - SL

allows articulating fitting
see page 200



Folding bellows - FB

provide spindle protection
see page 216



Spiral protective sleeve - SF

provide spindle protection
see page 220



3 phase motor

flange or foot mounting
see page 234 - 237

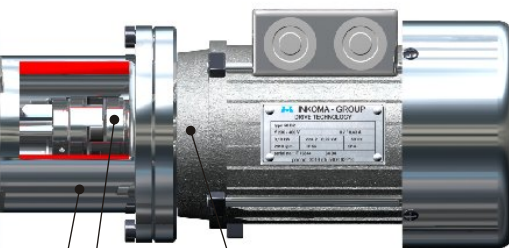

Handwheel - HR

for manual actuation
of the screw jack
see page 214

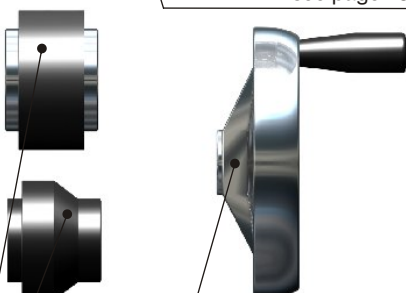

HSG screw jack (cubic design)

Accessories for translating spindle versions S, SA, SV, SVA

Page references

Rod end bearing - GSK
for simple attachment of the spindle end
see page 202

Clevis - GK
for simple attachment of the spindle end
see page 204

Mounting feet - BP
provides an alternative method
see page 210

Cardan shafts - GX/GE
provide torsionally stiff resilient connections
see page 222

Support bearings - SNH
to support extended cardan shafts
see page 224

Trunnion adaptor - KA/KAS
allows articulating fitting of flanged nut
see page 210

Bearing block - LB
base mounting bearing unit for KA or KAS
see page 214

Bearing flange - LF
base mounting bearing unit for KA or KAS
see page 214

Setting ring and limit switch with roller follower
for monitoring of the spindle position
see page 208

Setting ring and inductive proximity switch
for monitoring of the spindle position
see page 208

Safety nut - SFM-S
allows wear monitoring
see page 206

Mounting flange - BF
for simple attachment
of the spindle end
see page 202

Spiral protective sleeve - SF
provide spindle protection
see page 220

Folding bellows - FB
provide spindle protection
see page 216

Gear coupling - M
standard or light duty version
see page 226

Elaflex coupling - EFK
flexible shaft coupling
see page 224

Motor adaptor - MG
for positive and efficient
mounting of motors
see page 228

3 phase motor
flange or foot mounting
see page 234 - 237



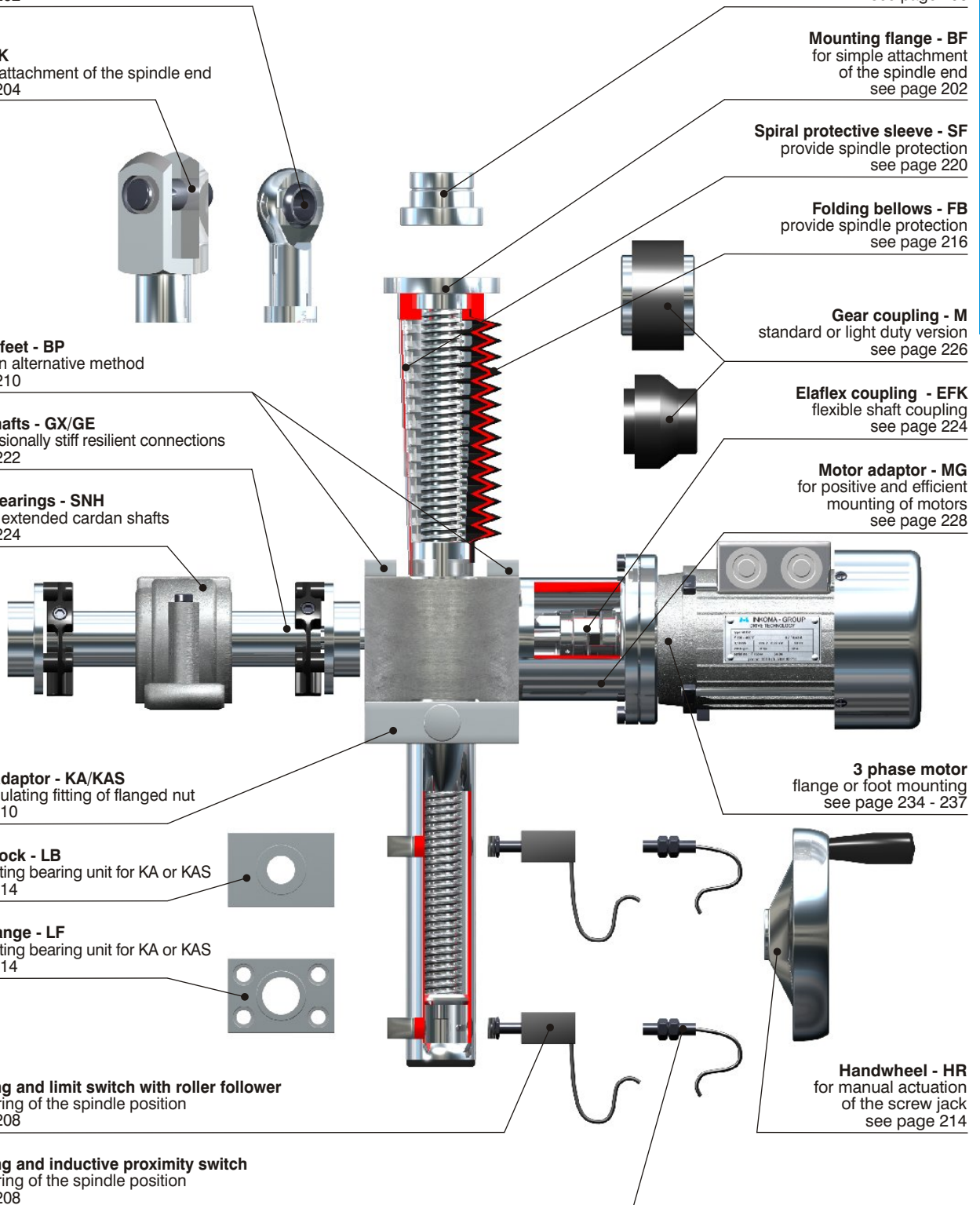









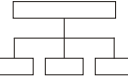
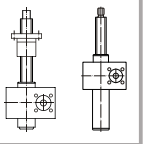

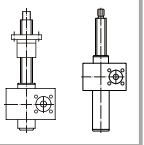

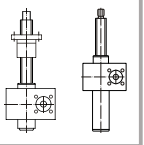
Handwheel - HR
for manual actuation
of the screw jack
see page 214

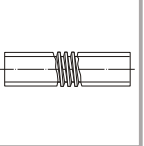

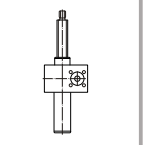
HSG screw jack (cubic design)

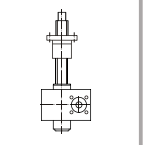

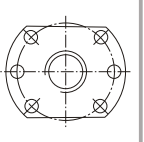







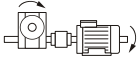

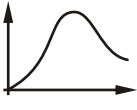

Contents list

HSG precision screw jacks with rotating and translating spindles

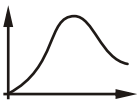
		Versions	page
		rotating version (R), translating version (S, SA, SV, SVA)	112
		Design of the lifting system	page
		method	113
		Dimensions HSG-0 to HSG-2	page
		trapezoidal spindle rotating and translating versions (R, S, SA, SV, SVA)	114 - 115
		Dimensions HSG-3 to HSG-5	page
		trapezoidal spindle rotating and translating versions (R, S, SA, SV, SVA)	116 - 117
		Dimensions HSG-200 to HSG-500	page
		trapezoidal spindle rotating and translating versions (R, S, SA, SV, SVA)	118 - 119
		Trapezoidal spindles for HSG-1 to HSG-500	page
		standard dimensions	120 - 121
		Dimensions HSG-1 to HSG-5	page
		ball screw spindle translating version (SA, SVA)	122 - 123
		Dimensions HSG-0 to HSG-200	page
		ball screw spindle rotating version (R)	124 - 125
		Flanged nut dimensions	page
		flanged nut to DIN 69051 for ball screw spindle rotating version (R)	126 - 127

Contents list

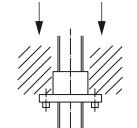
HSG precision screw jacks with rotating and translating spindles

		Selection of screw jacks	page
		notes about the design arrangements of screw jack systems, arrangement examples	128 - 129
		HSG - KSH definitions / calculations	page
		definition of the applied loads, torques and speeds calculation of the duty maximum duty ED [%/h]	130 - 131
		HSG - KSH calculations	page
		critical buckling loads on the lifting spindle $F_{crit.}$ [kN] critical spindle speed $n_{crit.}$ (only for rotating spindle version R)	132 - 133
		HSG - KSH calculations	page
		torque in the lifting spindle $M_{sp.}$ [Nm] braking torque $M_{br.}$ [Nm] input torque $M_{in.}$ [Nm] for each screw jack	134 - 135
		HSG - KSH calculations	page
		total input torque $M_{tot.}$ [Nm] input speed $n_{in.}$ [1/min], input power $P_{in.}$ [kW] actual lifting speed $V_{lift act.}$ [m/min]	136 - 137
		HSG - KSH gear housing material	page
		selection table	138
		Installation and maintenance	page
		assembly, maintenance of HSG-0 to HSG-5	139
	<ol style="list-style-type: none"> 1. <input type="checkbox"/> <input type="checkbox"/> 2. 3. <input type="checkbox"/> 	HSG - KSH questionnaire / accessories	page
		for quotation purposes accessories for version R (rotating spindle) accessories for version S (translating spindle)	140 - 142



HSG screw jack (cubic design)

Versions

Rotating version (R)

In rotating version (R) linear motion of the nut results from rotational motion in the spindle.

In this version the spindle is axially fixed in the gear housing.

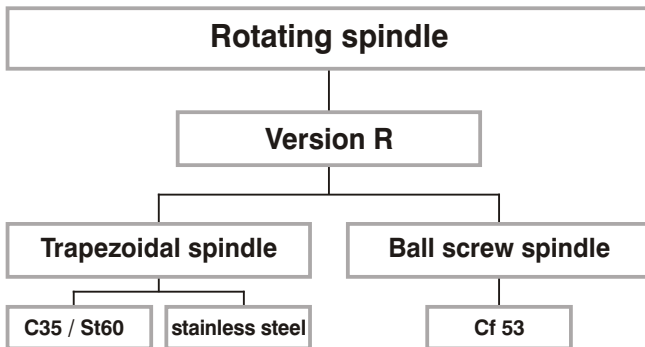

Translating version (S)

In translating version (S) linear motion results from the movement of the non rotating spindle through a rotating integral nut. The spindle is guided through the screw jack housing and must not be allowed to rotate. Over-travel of the spindle is prevented by a travel limiter (version SA). Spindle rotation can be prevented by the use of a rotation prevention device (SV). These two functions can be combined (version SVA).

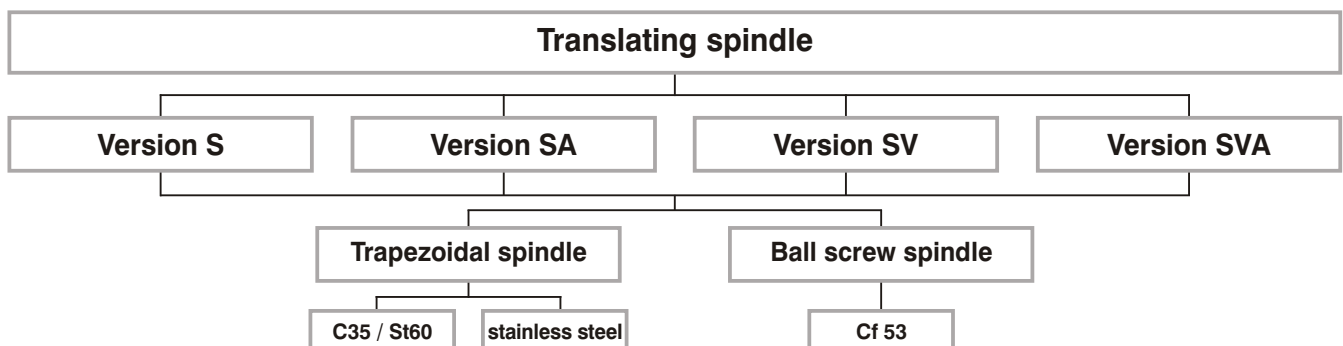

HSG screw jack (cubic design)

Design of the lifting system

Method

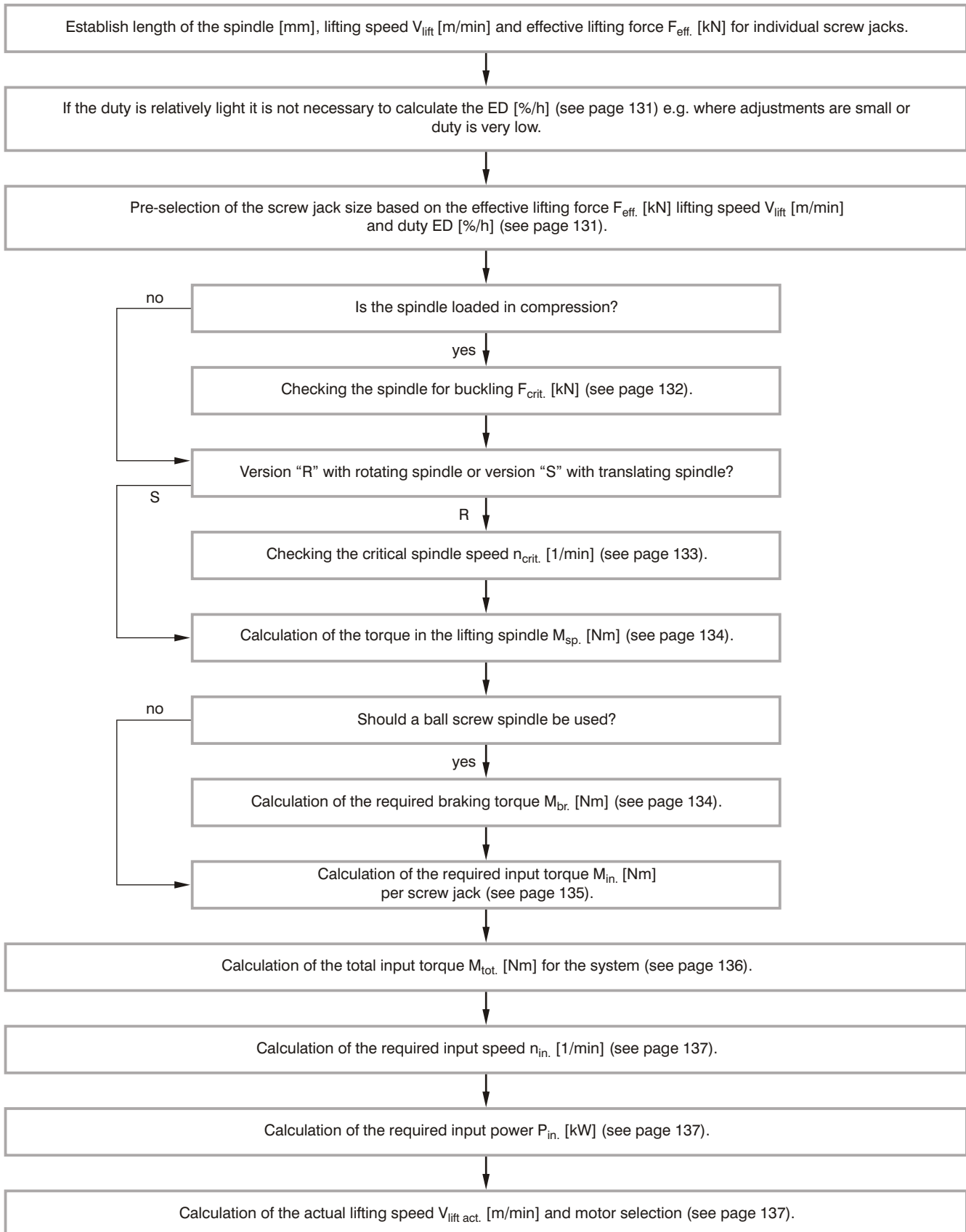

HSG screw jack (cubic design)

Dimensions HSG-0 to HSG-2

Trapezoidal spindle - rotating and translating versions (R, S, SA, SV, SVA)

All versions have an input shaft on side A and B as standard.
Single shaft versions can be optionally specified.

Versions:

- R:** Rotating spindle
- S:** Translating spindle
- SA:** Translating spindle with travel limiter
- SV:** Translating spindle with rotation prevention
- SVA:** Translating spindle with rotation prevention and travel limiter

Ratio: N: normal, L: slow

Lubrication: Grease

Material: see page 138

Accessories: see "Accessories" page 185 - 238

Questionnaire: see page 140 - 142

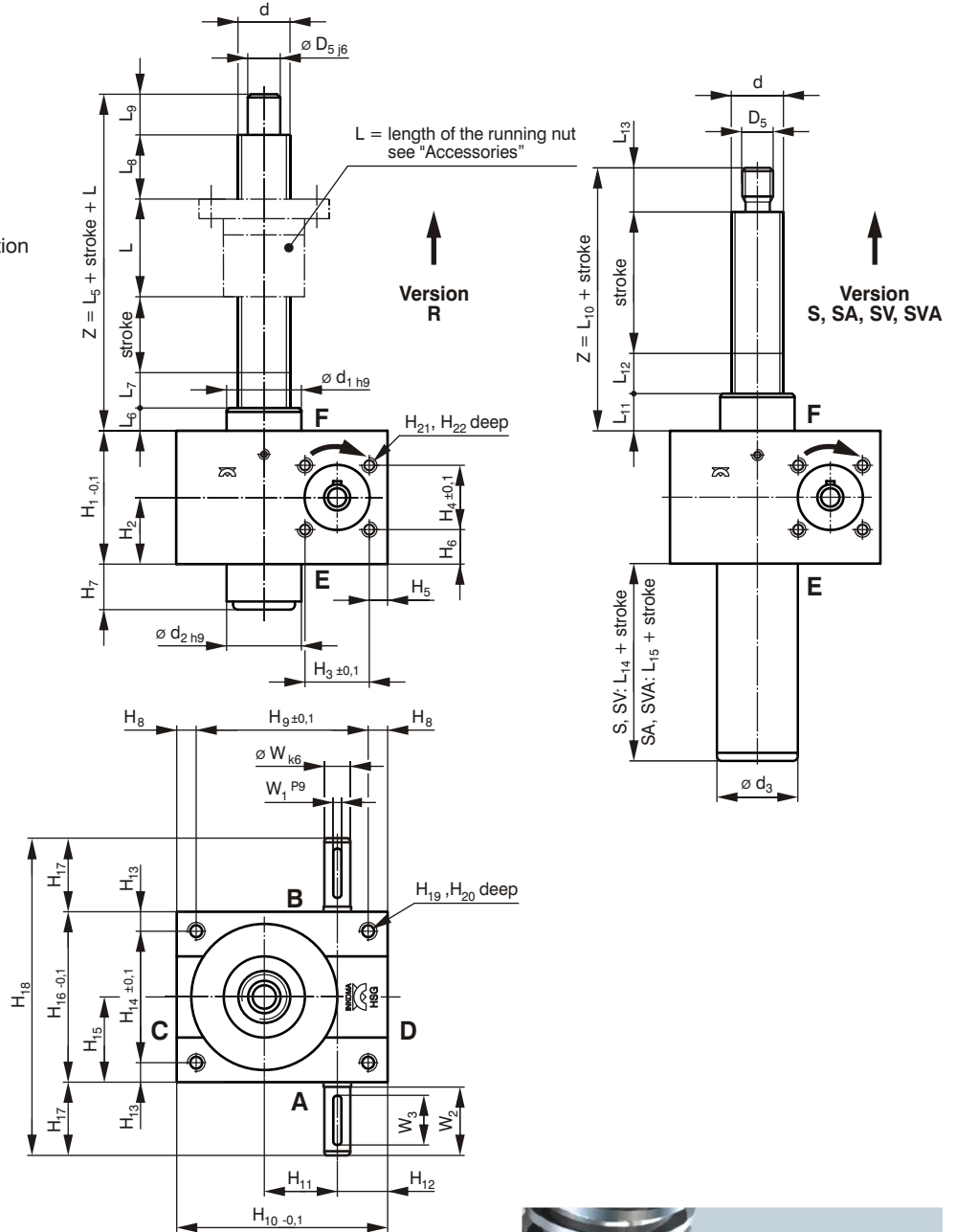

Ordering example:

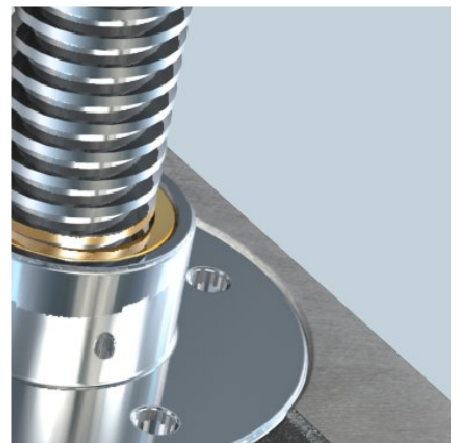
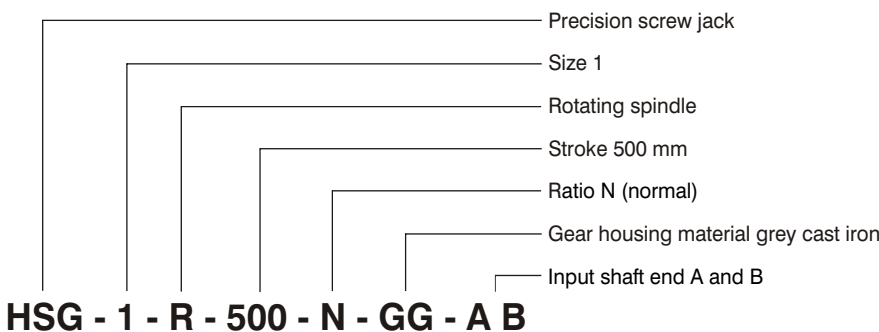

HSG screw jack (cubic design)

Order code	max. static lifting force ²⁾ [kN]	Lift per revolution N / L [mm]	Ratio N / L i	Mass [kg]	Dimensions [mm]																	
					d	D ₅	d ₁	d ₂ ¹⁾	d ₃	L ₅	L ₆	L ₇	L ₈	L ₉	L ₁₀	L ₁₁	L ₁₂	L ₁₃	L ₁₄	L ₁₅	H ₁	H ₂
HSG-0-R-stroke-N/L	2,5	1 / 0,25	4:1 / 16:1	0,8	Tr16x4	10	26	26	-	44	12	10	10	12	-	-	-	-	-	-	50	25
HSG-0-S-stroke-N/L	2,5	1 / 0,25	4:1 / 16:1	0,8	Tr16x4	M10	26	-	28	-	-	-	-	-	30	12	3	15	25	-	50	25
HSG-0-SA-stroke-N/L	2,5	1 / 0,25	4:1 / 16:1	0,8	Tr16x4	M10	26	-	28	-	-	-	-	-	30	12	3	15	-	45	50	25
HSG-0-SV-stroke-N/L	2,5	1 / 0,25	4:1 / 16:1	0,8	Tr16x4	M10	26	-	28	-	-	-	-	-	30	12	3	15	25	-	50	25
HSG-0-SVA-stroke-N/L	2,5	1 / 0,25	4:1 / 16:1	0,8	Tr16x4	M10	26	-	28	-	-	-	-	-	30	12	3	15	-	45	50	25
HSG-1-R-stroke-N/L	5	1 / 0,25	4:1 / 16:1	2,4	Tr18x4	12	30	30	-	65	12	19	19	15	-	-	-	-	-	-	62	31
HSG-1-S-stroke-N/L	5	1 / 0,25	4:1 / 16:1	2,4	Tr18x4	M12	30	-	33	-	-	-	-	-	35	12	4	19	25	-	62	31
HSG-1-SA-stroke-N/L	5	1 / 0,25	4:1 / 16:1	2,4	Tr18x4	M12	30	-	33	-	-	-	-	-	35	12	4	19	-	45	62	31
HSG-1-SV-stroke-N/L	5	1 / 0,25	4:1 / 16:1	2,4	Tr18x4	M12	30	-	33	-	-	-	-	-	35	12	4	19	25	-	62	31
HSG-1-SVA-stroke-N/L	5	1 / 0,25	4:1 / 16:1	2,4	Tr18x4	M12	30	-	33	-	-	-	-	-	35	12	4	19	-	45	62	31
HSG-2-R-stroke-N/L	10	1 / 0,25	4:1 / 16:1	3,4	Tr20x4	15	39	39	-	79,5	18,5	21	20	20	-	-	-	-	-	-	75	37,5
HSG-2-S-stroke-N/L	10	1 / 0,25	4:1 / 16:1	3,4	Tr20x4	M14	39	-	42	-	-	-	-	-	45	16	9	20	35	-	75	37,5
HSG-2-SA-stroke-N/L	10	1 / 0,25	4:1 / 16:1	3,4	Tr20x4	M14	39	-	42	-	-	-	-	-	45	16	9	20	-	55	75	37,5
HSG-2-SV-stroke-N/L	10	1 / 0,25	4:1 / 16:1	3,4	Tr20x4	M14	39	-	42	-	-	-	-	-	45	16	9	20	35	-	75	37,5
HSG-2-SVA-stroke-N/L	10	1 / 0,25	4:1 / 16:1	3,4	Tr20x4	M14	39	-	42	-	-	-	-	-	45	16	9	20	-	55	75	37,5

¹⁾ also supplied without locating diameter

²⁾ The values for max. load apply only for initial jack selection.

The actual permitted lifting force depends on the version of the jack and the operating conditions.

Order code	Dimensions [mm]																							
	H ₃	H ₄	H ₅	H ₆	H ₇ ¹⁾	H ₈	H ₉	H ₁₀	H ₁₁	H ₁₂	H ₁₃	H ₁₄	H ₁₅	H ₁₆	H ₁₇	H ₁₈	H ₁₉	H ₂₀	H ₂₁	H ₂₂	W	W ₁	W ₂	W ₃
HSG-0-R-stroke-N/L	25	25	5,5	12,5	16	6	48	60	20	18	6	38	25	50	21	92	M6	10	M5	5	9	3	20	16
HSG-0-S-stroke-N/L	25	25	5,5	12,5	-	6	48	60	20	18	6	38	25	50	21	92	M6	10	M5	5	9	3	20	16
HSG-0-SA-stroke-N/L	25	25	5,5	12,5	-	6	48	60	20	18	6	38	25	50	21	92	M6	10	M5	5	9	3	20	16
HSG-0-SV-stroke-N/L	25	25	5,5	12,5	-	6	48	60	20	18	6	38	25	50	21	92	M6	10	M5	5	9	3	20	16
HSG-0-SVA-stroke-N/L	25	25	5,5	12,5	-	6	48	60	20	18	6	38	25	50	21	92	M6	10	M5	5	9	3	20	16
HSG-1-R-stroke-N/L	32	32	8	15	17	10	60	80	25	24	10	52	36	72	24	120	M8	12	M5	10	10	3	22	18
HSG-1-S-stroke-N/L	32	32	8	15	-	10	60	80	25	24	10	52	36	72	24	120	M8	12	M5	10	10	3	22	18
HSG-1-SA-stroke-N/L	32	32	8	15	-	10	60	80	25	24	10	52	36	72	24	120	M8	12	M5	10	10	3	22	18
HSG-1-SV-stroke-N/L	32	32	8	15	-	10	60	80	25	24	10	52	36	72	24	120	M8	12	M5	10	10	3	22	18
HSG-1-SVA-stroke-N/L	32	32	8	15	-	10	60	80	25	24	10	52	36	72	24	120	M8	12	M5	10	10	3	22	18
HSG-2-R-stroke-N/L	35	35	10,5	20	21	11	78	100	32	28	11	63	42,5	85	27,5	140	M8	15	M6	10	14	5	25	20
HSG-2-S-stroke-N/L	35	35	10,5	20	-	11	78	100	32	28	11	63	42,5	85	27,5	140	M8	15	M6	10	14	5	25	20
HSG-2-SA-stroke-N/L	35	35	10,5	20	-	11	78	100	32	28	11	63	42,5	85	27,5	140	M8	15	M6	10	14	5	25	20
HSG-2-SV-stroke-N/L	35	35	10,5	20	-	11	78	100	32	28	11	63	42,5	85	27,5	140	M8	15	M6	10	14	5	25	20
HSG-2-SVA-stroke-N/L	35	35	10,5	20	-	11	78	100	32	28	11	63	42,5	85	27,5	140	M8	15	M6	10	14	5	25	20

¹⁾ also supplied without locating diameter

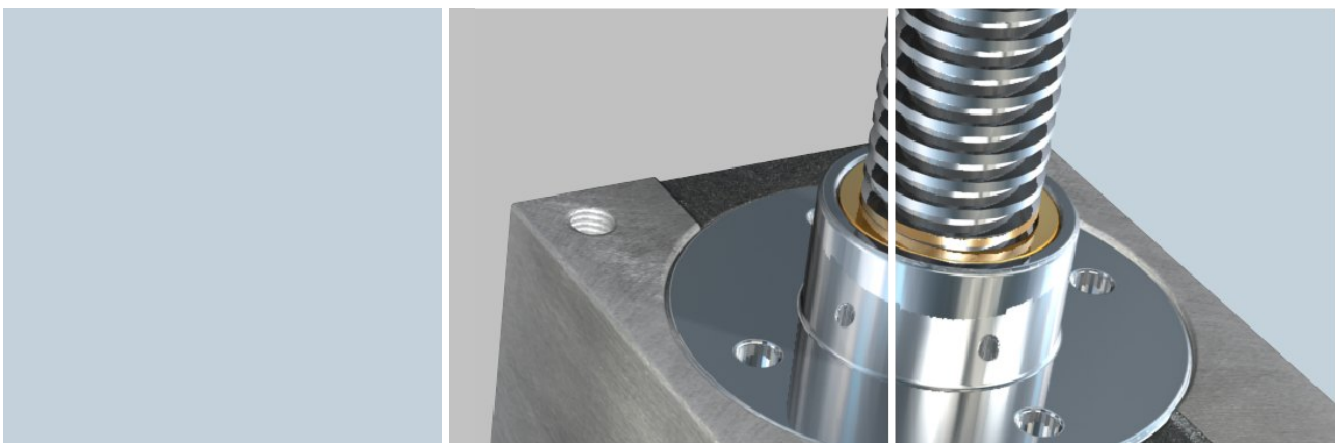

HSG screw jack (cubic design)

Dimensions HSG-3 to HSG-5

Trapezoidal spindle - rotating and translating versions (R, S, SA, SV, SVA)

All versions have an input shaft on side A and B as standard.
Single shaft versions can be optionally specified.

Versions:

- R:** Rotating spindle
- S:** Translating spindle
- SA:** Translating spindle with travel limiter
- SV:** Translating spindle with rotation prevention
- SVA:** Translating spindle with rotation prevention and travel limiter

Ratio: N: normal, L: slow

Lubrication: Grease

Material: see page 138

Accessories: see "Accessories" page 185 - 238

Questionnaire: see page 140 - 142

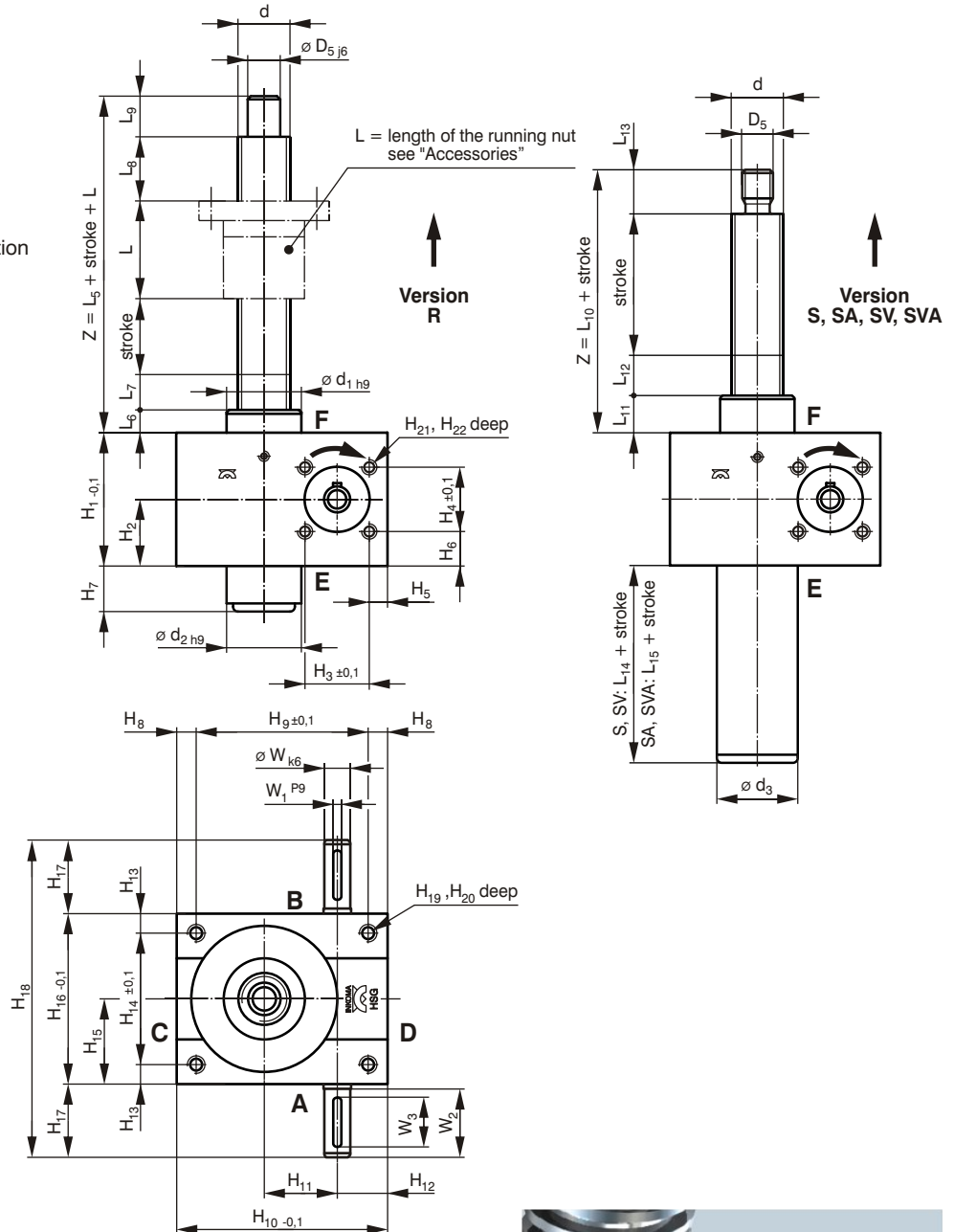

Ordering example:

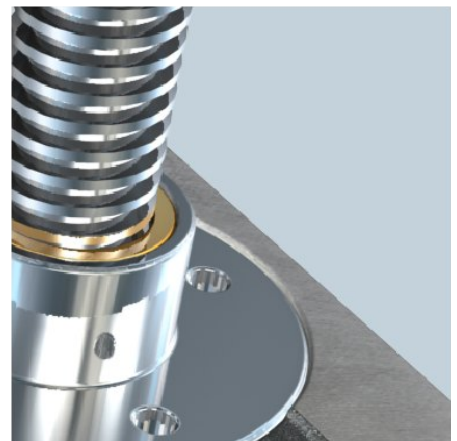
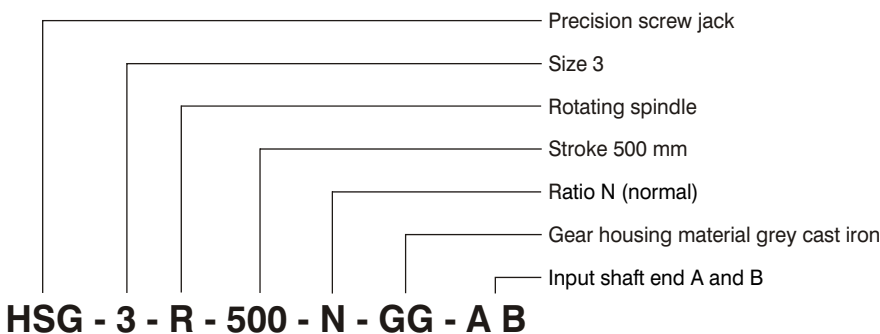

HSG screw jack (cubic design)

Order code	max. static lifting force ²⁾ [kN]	Lift per revolution N / L [mm]	Ratio N / L i	Mass [kg]	Dimensions [mm]																					
					d	D ₅	d ₁	d ₂ ¹⁾	d ₃	L ₅	L ₆	L ₇	L ₈	L ₉	L ₁₀	L ₁₁	L ₁₂	L ₁₃	L ₁₄	L ₁₅	H ₁	H ₂				
HSG-3-R-stroke-N/L	25	1 / 0,25	6:1 / 24:1	6,2	Tr30x6	20	46	46	-	80	14	21	20	25	-	-	-	-	-	-	-	-	-	-	82	41
HSG-3-S-stroke-N/L	25	1 / 0,25	6:1 / 24:1	6,2	Tr30x6	M20	46	-	50	-	-	-	-	-	50	23	5	22	35	-	-	-	-	82	41	
HSG-3-SA-stroke-N/L	25	1 / 0,25	6:1 / 24:1	6,2	Tr30x6	M20	46	-	50	-	-	-	-	-	50	23	5	22	-	58	82	41	-	-	-	
HSG-3-SV-stroke-N/L	25	1 / 0,25	6:1 / 24:1	6,2	Tr30x6	M20	46	-	50	-	-	-	-	-	50	23	5	22	35	-	-	-	-	82	41	
HSG-3-SVA-stroke-N/L	25	1 / 0,25	6:1 / 24:1	6,2	Tr30x6	M20	46	-	50	-	-	-	-	-	50	23	5	22	-	58	82	41	-	-	-	
HSG-4-R-stroke-N/L	50	1 / 0,25	7:1 / 28:1	16,5	Tr40x7	25	60	60	-	127	34	32	31	30	-	-	-	-	-	-	-	-	-	117	58,5	
HSG-4-S-stroke-N/L	50	1 / 0,25	7:1 / 28:1	16,5	Tr40x7	M30	60	-	65	-	-	-	-	-	65	32	4	29	50	-	-	-	-	117	58,5	
HSG-4-SA-stroke-N/L	50	1 / 0,25	7:1 / 28:1	16,5	Tr40x7	M30	60	-	65	-	-	-	-	-	65	32	4	29	-	75	117	58,5	-	-	-	
HSG-4-SV-stroke-N/L	50	1 / 0,25	7:1 / 28:1	16,5	Tr40x7	M30	60	-	65	-	-	-	-	-	65	32	4	29	50	-	-	-	-	117	58,5	
HSG-4-SVA-stroke-N/L	50	1 / 0,25	7:1 / 28:1	16,5	Tr40x7	M30	60	-	65	-	-	-	-	-	65	32	4	29	-	75	117	58,5	-	-	-	
HSG-5-R-stroke-N/L	100	1 / 0,25	9:1 / 36:1	34	Tr60x9	40	85	85	-	157	40	36	36	45	-	-	-	-	-	-	-	-	-	160	80	
HSG-5-S-stroke-N/L	100	1 / 0,25	9:1 / 36:1	34	Tr60x9	M36	85	-	90	-	-	-	-	-	95	40	7	48	60	-	-	-	-	160	80	
HSG-5-SA-stroke-N/L	100	1 / 0,25	9:1 / 36:1	34	Tr60x9	M36	85	-	90	-	-	-	-	-	95	40	7	48	-	105	160	80	-	-	-	
HSG-5-SV-stroke-N/L	100	1 / 0,25	9:1 / 36:1	34	Tr60x9	M36	85	-	90	-	-	-	-	-	95	40	7	48	60	-	-	-	-	160	80	
HSG-5-SVA-stroke-N/L	100	1 / 0,25	9:1 / 36:1	34	Tr60x9	M36	85	-	90	-	-	-	-	-	95	40	7	48	-	105	160	80	-	-	-	

¹⁾ also supplied without locating diameter

²⁾ The values for max. load apply only for initial jack selection.

The actual permitted lifting force depends on the version of the jack and the operating conditions.

Order code	Dimensions [mm]																							
	H ₃	H ₄	H ₅	H ₆	H ₇ ¹⁾	H ₈	H ₉	H ₁₀	H ₁₁	H ₁₂	H ₁₃	H ₁₄	H ₁₅	H ₁₆	H ₁₇	H ₁₈	H ₁₉	H ₂₀	H ₂₁	H ₂₂	W	W ₁	W ₂	W ₃
HSG-3-R-stroke-N/L	44	44	9	19	28	12	106	130	45	31	12	81	52,5	105	45	195	M10	15	M8	12	16	5	43	36
HSG-3-S-stroke-N/L	44	44	9	19	-	12	106	130	45	31	12	81	52,5	105	45	195	M10	15	M8	12	16	5	43	36
HSG-3-SA-stroke-N/L	44	44	9	19	-	12	106	130	45	31	12	81	52,5	105	45	195	M10	15	M8	12	16	5	43	36
HSG-3-SV-stroke-N/L	44	44	9	19	-	12	106	130	45	31	12	81	52,5	105	45	195	M10	15	M8	12	16	5	43	36
HSG-3-SVA-stroke-N/L	44	44	9	19	-	12	106	130	45	31	12	81	52,5	105	45	195	M10	15	M8	12	16	5	43	36
HSG-4-R-stroke-N/L	55	55	11,5	31	37	15	150	180	63	39	15	115	72,5	145	47,5	240	M12	16	M10	12	20	6	45	36
HSG-4-S-stroke-N/L	55	55	11,5	31	-	15	150	180	63	39	15	115	72,5	145	47,5	240	M12	16	M10	12	20	6	45	36
HSG-4-SA-stroke-N/L	55	55	11,5	31	-	15	150	180	63	39	15	115	72,5	145	47,5	240	M12	16	M10	12	20	6	45	36
HSG-4-SV-stroke-N/L	55	55	11,5	31	-	15	150	180	63	39	15	115	72,5	145	47,5	240	M12	16	M10	12	20	6	45	36
HSG-4-SVA-stroke-N/L	55	55	11,5	31	-	15	150	180	63	39	15	115	72,5	145	47,5	240	M12	16	M10	12	20	6	45	36
HSG-5-R-stroke-N/L	70	70	11	45	45	17	166	200	71	46	17	131	82,5	165	67,5	300	M20	30	M12	15	25	8	65	56
HSG-5-S-stroke-N/L	70	70	11	45	-	17	166	200	71	46	17	131	82,5	165	67,5	300	M20	30	M12	15	25	8	65	56
HSG-5-SA-stroke-N/L	70	70	11	45	-	17	166	200	71	46	17	131	82,5	165	67,5	300	M20	30	M12	15	25	8	65	56
HSG-5-SV-stroke-N/L	70	70	11	45	-	17	166	200	71	46	17	131	82,5	165	67,5	300	M20	30	M12	15	25	8	65	56
HSG-5-SVA-stroke-N/L	70	70	11	45	-	17	166	200	71	46	17	131	82,5	165	67,5	300	M20	30	M12	15	25	8	65	56

¹⁾ also supplied without locating diameter



HSG screw jack (cubic design)

Dimensions HSG-200 to HSG-500

Trapezoidal spindle - rotating and translating versions (R, S, SA, SV, SVA)

All versions have an input shaft on side A and B as standard.
Single shaft versions can be optionally specified.

Versions:

- R:** Rotating spindle
- S:** Translating spindle
- SA:** Translating spindle with travel limiter
- SV:** Translating spindle with rotation prevention
- SVA:** Translating spindle with rotation prevention and travel limiter

Ratio: N: normal, L: slow

Lubrication: Grease

Material: see page 138

Accessories: see "Accessories" page 185 - 238

Questionnaire: see page 140 - 142

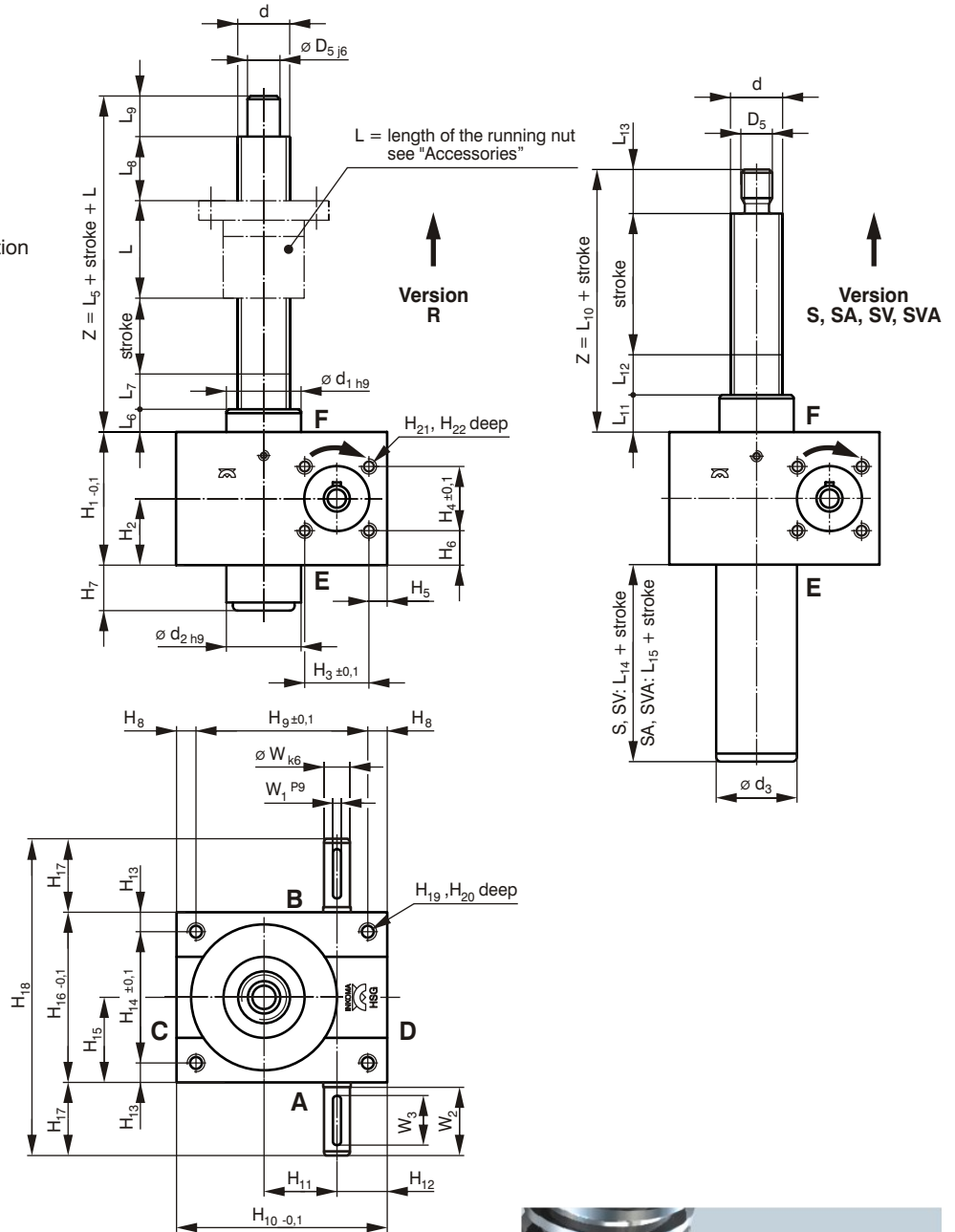

Ordering example:

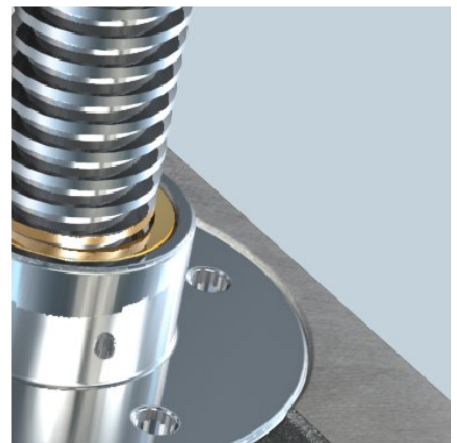
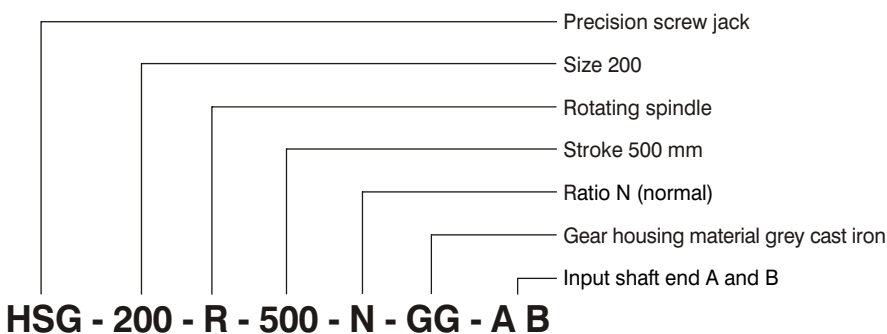

HSG screw jack (cubic design)

Order code	max. static lifting force ²⁾ [kN]	Lift per revolution N / L [mm]	Ratio N / L i	Mass [kg]	Dimensions [mm]																	
					d	D ₅	d ₁	d ₂	d ₃	L ₅	L ₆	L ₇	L ₈	L ₉	L ₁₀	L ₁₁	L ₁₂	L ₁₃	L ₁₄	L ₁₅	H ₁	H ₂
HSG-200-R-stroke-N/L	200	1 / 0,25	10:1 / 40:1	57	Tr70x10	55	120	105	-	160	40	25	25	70	-	-	-	-	-	-	165	82,5
HSG-200-S-stroke-N/L	200	1 / 0,25	10:1 / 40:1	57	Tr70x10	M56x2	120	-	110	-	-	-	-	-	110	40	12	58	60	-	165	82,5
HSG-200-SA-stroke-N/L	200	1 / 0,25	10:1 / 40:1	57	Tr70x10	M56x2	120	-	110	-	-	-	-	-	110	40	12	58	-	115	165	82,5
HSG-200-SV-stroke-N/L	200	1 / 0,25	10:1 / 40:1	57	Tr70x10	M56x2	120	-	110	-	-	-	-	-	110	40	12	58	60	-	165	82,5
HSG-200-SVA-stroke-N/L	200	1 / 0,25	10:1 / 40:1	57	Tr70x10	M56x2	120	-	110	-	-	-	-	-	110	40	12	58	-	115	165	82,5
HSG-300-R-stroke-N/L	300	1 / 0,25	12:1 / 48:1	75	Tr90x12	70	145	- 1)	-	180	50	25	25	80	-	-	-	-	-	-	220	110
HSG-300-S-stroke-N/L	300	1 / 0,25	12:1 / 48:1	75	Tr90x12	M70x1,5	145	-	150	-	-	-	-	-	135	50	15	70	85	-	220	110
HSG-300-SA-stroke-N/L	300	1 / 0,25	12:1 / 48:1	75	Tr90x12	M70x1,5	145	-	150	-	-	-	-	-	135	50	15	70	-	135	220	110
HSG-300-SV-stroke-N/L	300	1 / 0,25	12:1 / 48:1	75	Tr90x12	M70x1,5	145	-	150	-	-	-	-	-	135	50	15	70	85	-	220	110
HSG-300-SVA-stroke-N/L	300	1 / 0,25	12:1 / 48:1	75	Tr90x12	M70x1,5	145	-	150	-	-	-	-	-	135	50	15	70	-	135	220	110
HSG-400-R-stroke-N/L	400	1 / 0,25	12:1 / 48:1	75	Tr100x12	80	155	- 1)	-	200	50	25	25	100	-	-	-	-	-	-	250	125
HSG-400-S-stroke-N/L	400	1 / 0,25	12:1 / 48:1	75	Tr100x12	M80x2	155	-	160	-	-	-	-	-	160	50	16	94	100	-	250	125
HSG-400-SA-stroke-N/L	400	1 / 0,25	12:1 / 48:1	75	Tr100x12	M80x2	155	-	160	-	-	-	-	-	160	50	16	94	-	140	250	125
HSG-400-SV-stroke-N/L	400	1 / 0,25	12:1 / 48:1	75	Tr100x12	M80x2	155	-	160	-	-	-	-	-	160	50	16	94	100	-	250	125
HSG-400-SVA-stroke-N/L	400	1 / 0,25	12:1 / 48:1	75	Tr100x12	M80x2	155	-	160	-	-	-	-	-	160	50	16	94	-	140	250	125
HSG-500-R-stroke-N/L	500	1 / 0,25	14:1 / 56:1	165	Tr120x14	95	170	- 1)	-	240	60	30	30	120	-	-	-	-	-	-	266	133
HSG-500-S-stroke-N/L	500	1 / 0,25	14:1 / 56:1	165	Tr120x14	M100x3	170	-	180	-	-	-	-	-	200	60	22	118	115	-	266	133
HSG-500-SA-stroke-N/L	500	1 / 0,25	14:1 / 56:1	165	Tr120x14	M100x3	170	-	180	-	-	-	-	-	200	60	22	118	-	155	266	133
HSG-500-SV-stroke-N/L	500	1 / 0,25	14:1 / 56:1	165	Tr120x14	M100x3	170	-	180	-	-	-	-	-	200	60	22	118	115	-	266	133
HSG-500-SVA-stroke-N/L	500	1 / 0,25	14:1 / 56:1	165	Tr120x14	M100x3	170	-	180	-	-	-	-	-	200	60	22	118	-	155	266	133

1) locating diameter to customer specification

2) The values for max. load apply only for initial jack selection.

The actual permitted lifting force depends on the version of the jack and the operating conditions.

Order code	Dimensions [mm]																							
	H ₃	H ₄	H ₅	H ₆	H ₇	H ₈	H ₉	H ₁₀	H ₁₁	H ₁₂	H ₁₃	H ₁₄	H ₁₅	H ₁₆	H ₁₇	H ₁₈	H ₁₉	H ₂₀	H ₂₁	H ₂₂	W	W ₁	W ₂	W ₃
HSG-200-R-stroke-N/L	80	80	20	42,5	45	25	190	240 ²⁾	80	60	25	170	110	220	67,5	355	M30	36	M16	20	30	8	65	56
HSG-200-S-stroke-N/L	80	80	20	42,5	-	25	190	240 ²⁾	80	60	25	170	110	220	67,5	355	M30	36	M16	20	30	8	65	56
HSG-200-SA-stroke-N/L	80	80	20	42,5	-	25	190	240 ²⁾	80	60	25	170	110	220	67,5	355	M30	36	M16	20	30	8	65	56
HSG-200-SV-stroke-N/L	80	80	20	42,5	-	25	190	240 ²⁾	80	60	25	170	110	220	67,5	355	M30	36	M16	20	30	8	65	56
HSG-200-SVA-stroke-N/L	80	80	20	42,5	-	25	190	240 ²⁾	80	60	25	170	110	220	67,5	355	M30	36	M16	20	30	8	65	56
HSG-300-R-stroke-N/L	-	-	-	-	- 1)	30	225	285	100	60	30	190	125	250	67,5	385	M36	49	-	-	32	10	65	56
HSG-300-S-stroke-N/L	-	-	-	-	-	30	225	285	100	60	30	190	125	250	67,5	385	M36	49	-	-	32	10	65	56
HSG-300-SA-stroke-N/L	-	-	-	-	-	30	225	285	100	60	30	190	125	250	67,5	385	M36	49	-	-	32	10	65	56
HSG-300-SV-stroke-N/L	-	-	-	-	-	30	225	285	100	60	30	190	125	250	67,5	385	M36	49	-	-	32	10	65	56
HSG-300-SVA-stroke-N/L	-	-	-	-	-	30	225	285	100	60	30	190	125	250	67,5	385	M36	49	-	-	32	10	65	56
HSG-400-R-stroke-N/L	-	-	-	-	- 1)	35	265	335	125	70	30	240	150	300	85	470	M36	49	-	-	42	12	83	70
HSG-400-S-stroke-N/L	-	-	-	-	-	35	265	335	125	70	30	240	150	300	85	470	M36	49	-	-	42	12	83	70
HSG-400-SA-stroke-N/L	-	-	-	-	-	35	265	335	125	70	30	240	150	300	85	470	M36	49	-	-	42	12	83	70
HSG-400-SV-stroke-N/L	-	-	-	-	-	35	265	335	125	70	30	240	150	300	85	470	M36	49	-	-	42	12	83	70
HSG-400-SVA-stroke-N/L	-	-	-	-	-	35	265	335	125	70	30	240	150	300	85	470	M36	49	-	-	42	12	83	70
HSG-500-R-stroke-N/L	-	-	-	-	- 1)	35	290	360	135	75	35	260	165	330	100	530	M42	56	-	-	48	14	-	90
HSG-500-S-stroke-N/L	-	-	-	-	-	35	290	360	135	75	35	260	165	330	100	530	M42	56	-	-	48	14	-	90
HSG-500-SA-stroke-N/L	-	-	-	-	-	35	290	360	135	75	35	260	165	330	100	530	M42	56	-	-	48	14	-	90
HSG-500-SV-stroke-N/L	-	-	-	-	-	35	290	360	135	75	35	260	165	330	100	530	M42	56	-	-	48	14	-	90
HSG-500-SVA-stroke-N/L	-	-	-	-	-	35	290	360	135	75	35	260	165	330	100	530	M42	56	-	-	48	14	-	90

1) locating diameter to customer specification

2) Tolerance ±0,5

HSG screw jack (cubic design)

Trapezoidal spindles for HSG-1 to HSG-500

Standard dimensions

The trapezoidal spindles are rolled to the highest standard of precision.

Metric ISO trapezoidal spindles are manufactured in compliance with DIN 103. To achieve a larger thread root radius, the core diameter for our spindles is fractionally smaller than standard. Reworking of the outer diameter is carried out in soft jaws.

Our standard spindles are manufactured from St 60 or C 35. They can also be supplied in stainless steel.

Thread quality : 7 e

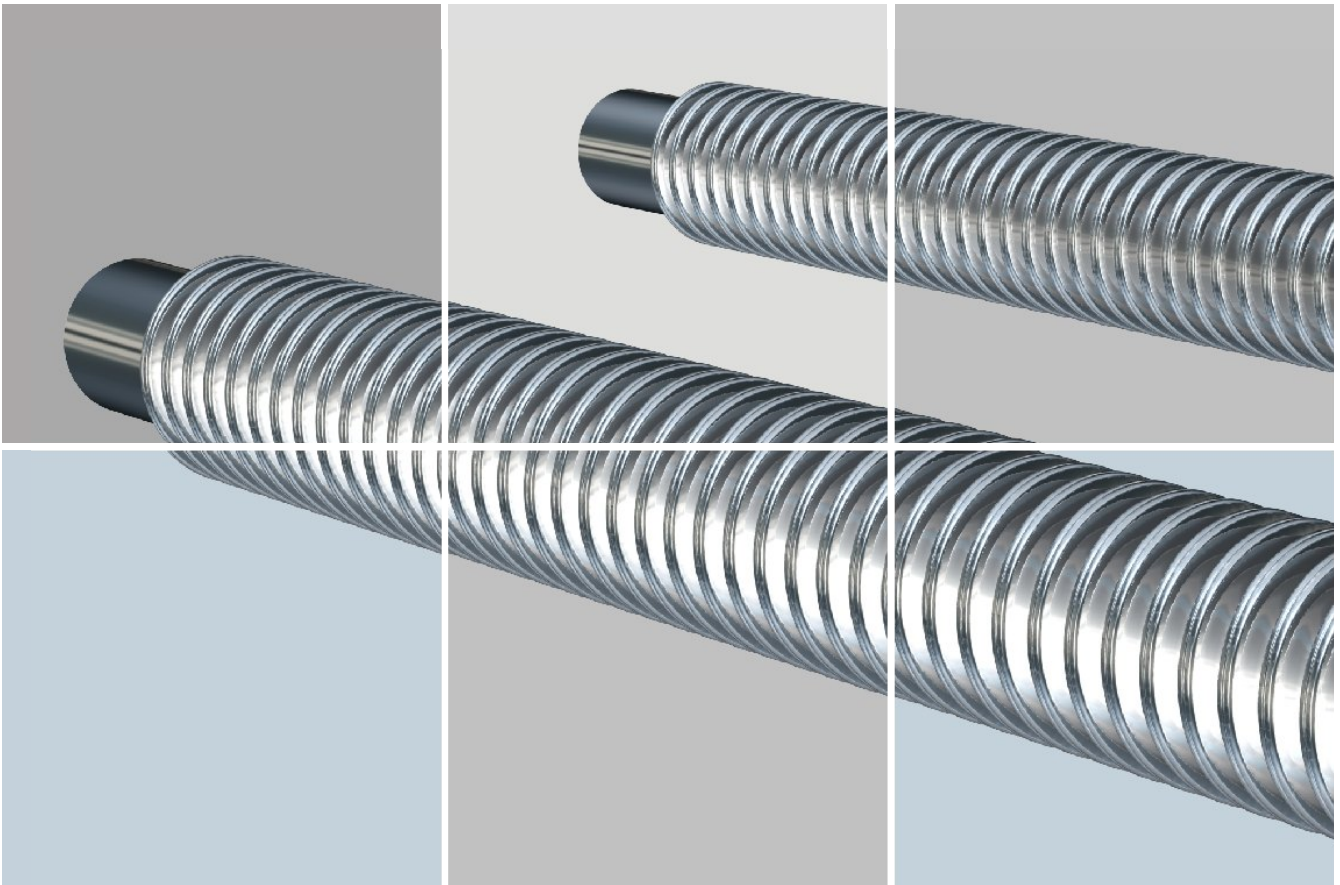
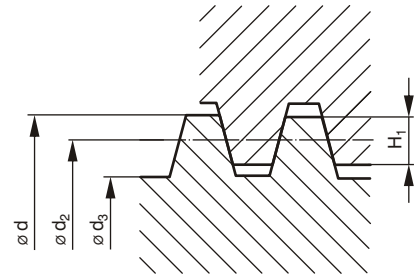
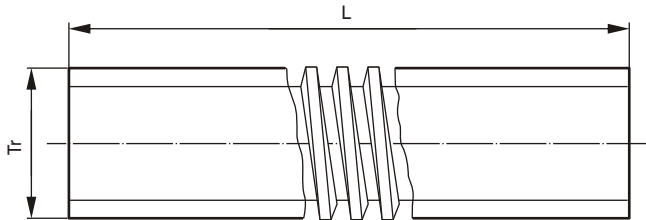

HSG screw jack (cubic design)

Size	Dimensions [mm]					Precision [$\mu\text{m}/300\text{mm}$]	Straightness [mm/300mm]
	d	d _{2 min}	d _{2 max}	d ₃	H ₁		
Tr 16 x 4	16	13,640	13,905	10,80	2	50	0,1
Tr 18 x 4	18	15,640	15,905	12,80	2	50	0,1
Tr 20 x 4	20	17,640	17,905	14,80	2	50	0,1
Tr 24 x 5	24	21,094	21,394	17,50	2,5	50	0,1
Tr 30 x 6	30	26,547	26,882	21,90	3	50	0,1
Tr 40 x 7	40	36,020	36,375	30,50	3,5	50	0,1
Tr 60 x 9	60	54,935	55,360	48,15	4,5	200	0,3
Tr 70 x 10	70	64,425	64,850	57,00	5	200	0,3
Tr 90 x 12	90	83,355	83,830	77,00	6	200	0,5
Tr 100 x 12	100	93,330	93,830	86,215	6	200	0,5
Tr 120 x 14	120	112,290	112,820	103,157	7	200	0,5

Size	Lead angle at flank diameter	Theoretical efficiency (for $\mu=0,1$) η [-]	Mass [kg/m]	Geometric moment of inertia [cm ⁴]	Section modulus [cm ³]	Polar moment of inertia [cm ³]	Mass moment of inertia [kg m ² /m]
Tr 16 x 4	5° 11'	0,46	1,21	0,067	0,124	0,248	2,96 x 10 ⁻⁵
Tr 18 x 4	4° 32'	0,43	1,58	0,132	0,206	0,412	5,05 x 10 ⁻⁵
Tr 20 x 4	4° 2'	0,40	2,00	0,236	0,318	0,637	8,10 x 10 ⁻⁵
Tr 24 x 5	4° 14'	0,41	2,85	0,460	0,526	1,052	1,65 x 10 ⁻⁴
Tr 30 x 6	4° 2'	0,40	4,50	1,130	1,030	2,060	4,10 x 10 ⁻⁴
Tr 40 x 7	3° 29'	0,37	8,00	4,250	2,790	5,580	1,37 x 10 ⁻³
Tr 60 x 9	2° 57'	0,33	18,00	26,400	11,000	22,000	7,30 x 10 ⁻³
Tr 70 x 10	2° 48'	0,32	26,00	51,800	18,200	36,400	1,40 x 10 ⁻²
Tr 90 x 12	2° 36'	0,30	43,75	172,470	44,797	89,595	3,86 x 10 ⁻²
Tr 100 x 12	2° 20'	0,27	54,78	281,078	64,616	129,231	6,05 x 10 ⁻²
Tr 120 x 14	2° 15'	0,26	84,00	573,962	110,377	220,755	13,4 x 10 ⁻²

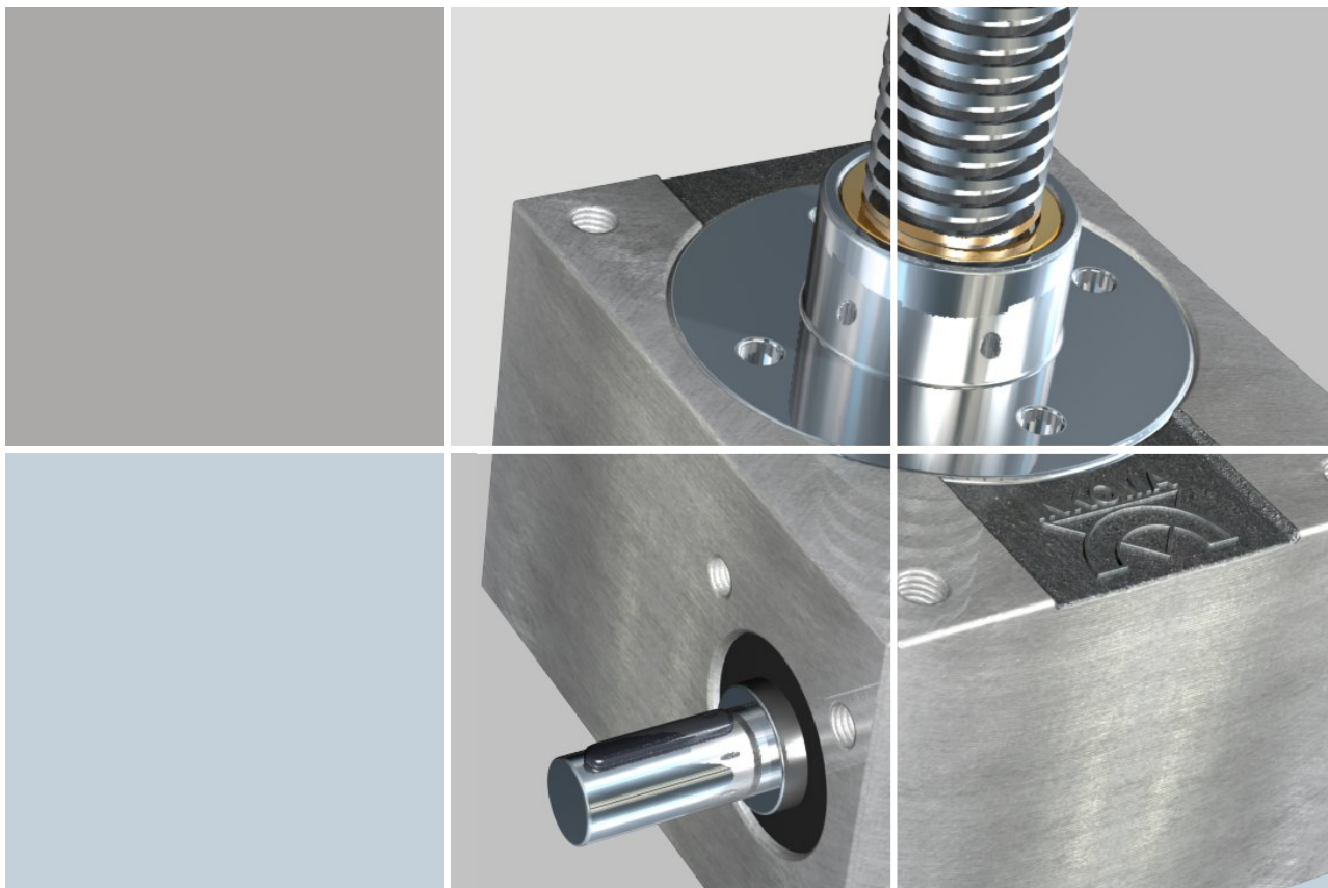

HSG screw jack (cubic design)

Dimensions HSG-1 to HSG-5

Ball screw spindle - translating version (SA, SVA)

All versions have an input shaft on side A and B as standard.
Single shaft versions can be optionally specified.

Versions:

SA: Translating spindle with travel limiter

SVA: Translating spindle with rotation prevention and travel limiter

Ratio: N: normal, L: slow

Lubrication: Grease

Material: see page 138

Accessories: see "Accessories" page 185 - 238

Questionnaire: see page 140 - 142

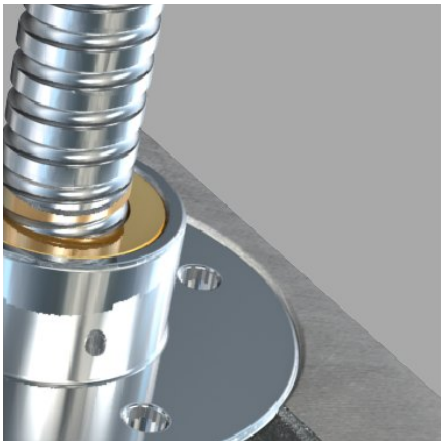
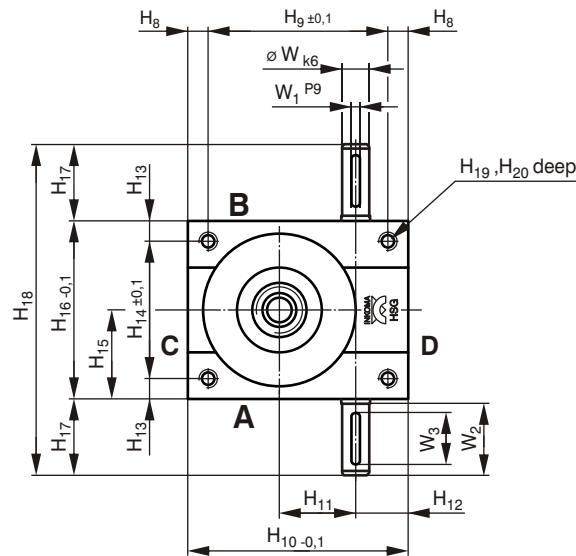
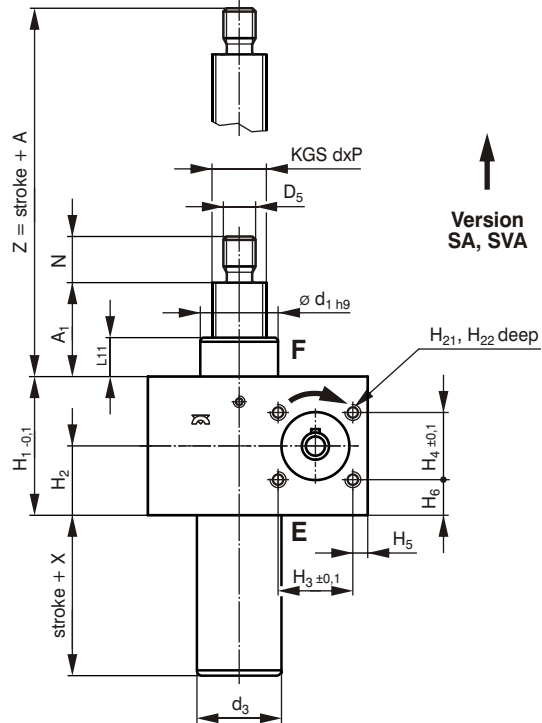

Ordering example:

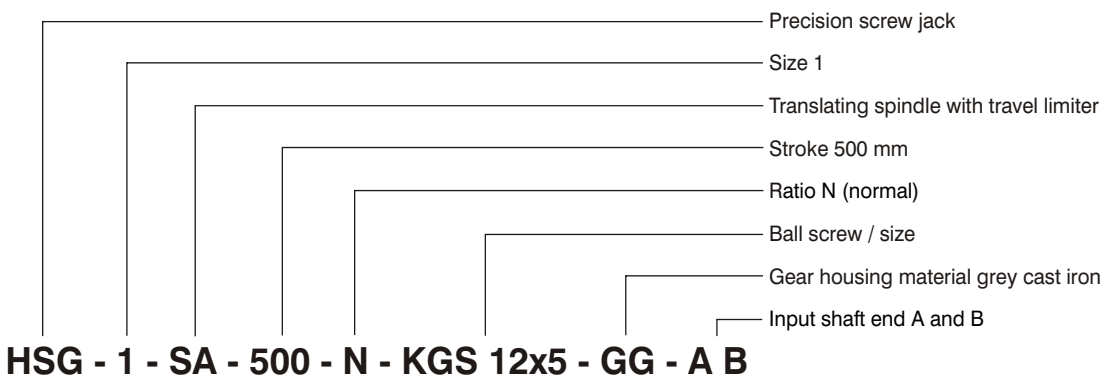

HSG screw jack (cubic design)

Order code	Lifting force $F_{dyn.}$ [kN]	max. static lifting force ¹⁾ $F_{stat.}$ [kN]	Lift per revolution [mm]	Ratio i	Mass [kg]	Dimensions [mm]															
						KGS dxP	D_5	d_1	SA $\varnothing d_3$	SVA $\square d_3$	SA X	SVA X	A	A_1	N	H_1	H_2	H_3	H_4		
						HSG-1-SA/SVA-stroke-N-KGS-12x5	2,5	2,5	1,25	4:1	2,4	12x5	M10	30	33	34	45	50	35	20	15
HSG-1-SA/SVA-stroke-L-KGS-12x5	2,5	2,5	0,31	16:1	2,4	12x5	M10	30	33	34	45	50	35	20	15	62	31	32	32		
HSG-2-SA/SVA-stroke-N-KGS-16x5	9,3	10	1,25	4:1	3,4	16x5	M12	39	42	45	55	60	45	26	19	75	37,5	35	35		
HSG-2-SA/SVA-stroke-L-KGS-16x5	9,3	10	0,31	16:1	3,4	16x5	M12	39	42	45	55	60	45	26	19	75	37,5	35	35		
HSG-3-SA/SVA-stroke-N-KGS-25x5	12,3	22,5	0,83	6:1	6,2	25x5	M14	46	50	50	58	70	50	30	20	82	41	44	44		
HSG-3-SA/SVA-stroke-N-KGS-25x10	13,2	25	1,67	6:1	6,2	25x10	M14	46	50	50	58	70	50	30	20	82	41	44	44		
HSG-3-SA/SVA-stroke-L-KGS-25x5	12,3	22,5	0,20	24:1	6,2	25x5	M14	46	50	50	58	70	50	30	20	82	41	44	44		
HSG-3-SA/SVA-stroke-L-KGS-25x10	13,2	25	0,41	24:1	6,2	25x10	M14	46	50	50	58	70	50	30	20	82	41	44	44		
HSG-4-SA/SVA-stroke-N-KGS-32x5	21,5	49,3	0,71	7:1	16,5	32x5	M20	60	65	70	75	85	65	43	22	117	58,5	55	55		
HSG-4-SA/SVA-stroke-N-KGS-32x10	33,4	50	1,43	7:1	16,5	32x10	M20	60	65	70	75	85	65	43	22	117	58,5	55	55		
HSG-4-SA/SVA-stroke-L-KGS-32x5	21,5	49,3	0,18	28:1	16,5	32x5	M20	60	65	70	75	85	65	43	22	117	58,5	55	55		
HSG-4-SA/SVA-stroke-L-KGS-32x10	33,4	50	0,36	28:1	16,5	32x10	M20	60	65	70	75	85	65	43	22	117	58,5	55	55		
HSG-5-SA/SVA-stroke-N-KGS-40x5	20,3	59,2	0,55	9:1	16,5	40x5	M30	85	90	90	105	115	95	66	29	160	80	70	70		
HSG-5-SA/SVA-stroke-N-KGS-40x10	55	100	1,11	9:1	16,5	40x10	M30	85	90	90	105	115	95	66	29	160	80	70	70		
HSG-5-SA/SVA-stroke-N-KGS-50x5	22	75,7	0,55	9:1	16,5	50x5	M36	85	90	90	105	115	114	66	48	160	80	70	70		
HSG-5-SA/SVA-stroke-N-KGS-50x10	58,7	100	1,11	9:1	16,5	50x10	M36	85	90	90	105	115	114	66	48	160	80	70	70		
HSG-5-SA/SVA-stroke-L-KGS-40x5	20,3	59,2	0,14	36:1	16,5	40x5	M30	85	90	90	105	115	95	66	29	160	80	70	70		
HSG-5-SA/SVA-stroke-L-KGS-40x10	55	100	0,28	36:1	16,5	40x10	M30	85	90	90	105	115	95	66	29	160	80	70	70		
HSG-5-SA/SVA-stroke-L-KGS-50x5	22	75,7	0,13	36:1	16,5	50x5	M36	85	90	90	105	115	114	66	48	160	80	70	70		
HSG-5-SA/SVA-stroke-L-KGS-50x10	58,7	100	0,28	36:1	16,5	50x10	M36	85	90	90	105	115	114	66	48	160	80	70	70		

¹⁾ The values for max. load apply only for initial jack selection. The actual permitted lifting force depends on the version of the jack and the operating conditions.

Order code	Dimensions [mm]																					
	H_5	H_6	H_8	H_9	H_{10}	H_{11}	H_{12}	H_{13}	H_{14}	H_{15}	H_{16}	H_{17}	H_{18}	H_{19}	H_{20}	H_{21}	H_{22}	L_{11}	W	W_1	W_2	W_3
HSG-1-SA/SVA-stroke-N-KGS-12x5	8	15	10	60	80	25	24	10	52	36	72	24	120	M8	12	M5	10	12	10	3	22	18
HSG-1-SA/SVA-stroke-L-KGS-12x5	8	15	10	60	80	25	24	10	52	36	72	24	120	M8	12	M5	10	12	10	3	22	18
HSG-2-SA/SVA-stroke-N-KGS-16x5	10,5	20	11	78	100	32	28	11	63	42,5	85	27,5	140	M8	15	M6	10	16	14	5	25	20
HSG-2-SA/SVA-stroke-L-KGS-16x5	10,5	20	11	78	100	32	28	11	63	42,5	85	27,5	140	M8	15	M6	10	16	14	5	25	20
HSG-3-SA/SVA-stroke-N-KGS-25x5	9	19	12	106	130	45	31	12	81	52,5	105	45	195	M10	15	M8	12	23	16	5	43	36
HSG-3-SA/SVA-stroke-N-KGS-25x10	9	19	12	106	130	45	31	12	81	52,5	105	45	195	M10	15	M8	12	23	16	5	43	36
HSG-3-SA/SVA-stroke-L-KGS-25x5	9	19	12	106	130	45	31	12	81	52,5	105	45	195	M10	15	M8	12	23	16	5	43	36
HSG-3-SA/SVA-stroke-L-KGS-25x10	9	19	12	106	130	45	31	12	81	52,5	105	45	195	M10	15	M8	12	23	16	5	43	36
HSG-4-SA/SVA-stroke-N-KGS-32x5	11,5	31	15	150	180	63	39	15	115	72,5	145	47,5	240	M12	16	M10	12	32	20	6	45	36
HSG-4-SA/SVA-stroke-N-KGS-32x10	11,5	31	15	150	180	63	39	15	115	72,5	145	47,5	240	M12	16	M10	12	32	20	6	45	36
HSG-4-SA/SVA-stroke-L-KGS-32x5	11,5	31	15	150	180	63	39	15	115	72,5	145	47,5	240	M12	16	M10	12	32	20	6	45	36
HSG-4-SA/SVA-stroke-L-KGS-32x10	11,5	31	15	150	180	63	39	15	115	72,5	145	47,5	240	M12	16	M10	12	32	20	6	45	36
HSG-5-SA/SVA-stroke-N-KGS-40x5	11	45	17	166	200	71	46	17	131	82,5	165	67,5	300	M20	30	M12	15	40	25	8	65	56
HSG-5-SA/SVA-stroke-N-KGS-40x10	11	45	17	166	200	71	46	17	131	82,5	165	67,5	300	M20	30	M12	15	40	25	8	65	56
HSG-5-SA/SVA-stroke-N-KGS-50x5	11	45	17	166	200	71	46	17	131	82,5	165	67,5	300	M20	30	M12	15	40	25	8	65	56
HSG-5-SA/SVA-stroke-N-KGS-50x10	11	45	17	166	200	71	46	17	131	82,5	165	67,5	300	M20	30	M12	15	40	25	8	65	56
HSG-5-SA/SVA-stroke-L-KGS-40x5	11	45	17	166	200	71	46	17	131	82,5	165	67,5	300	M20	30	M12	15	40	25	8	65	56
HSG-5-SA/SVA-stroke-L-KGS-40x10	11	45	17	166	200	71	46	17	131	82,5	165	67,5	300	M20	30	M12	15	40	25	8	65	56
HSG-5-SA/SVA-stroke-L-KGS-50x5	11	45	17	166	200	71	46	17	131	82,5	165	67,5	300	M20	30	M12	15	40	25	8	65	56
HSG-5-SA/SVA-stroke-L-KGS-50x10	11	45	17	166	200	71	46	17	131	82,5	165	67,5	300	M20	30	M12	15	40	25	8	65	56

HSG screw jack (cubic design)

Dimensions HSG-0 to HSG-200

Ball screw spindle - rotating version (R)

All versions have an input shaft on side A and B as standard. Single shaft versions can be optionally specified.

Versions:

R: Rotating spindle

Ratio: N: normal, L: slow

Lubrication: Grease

Material: see page 138

Accessories: see "Accessories" page 185 - 238

Questionnaire: see page 140 - 142

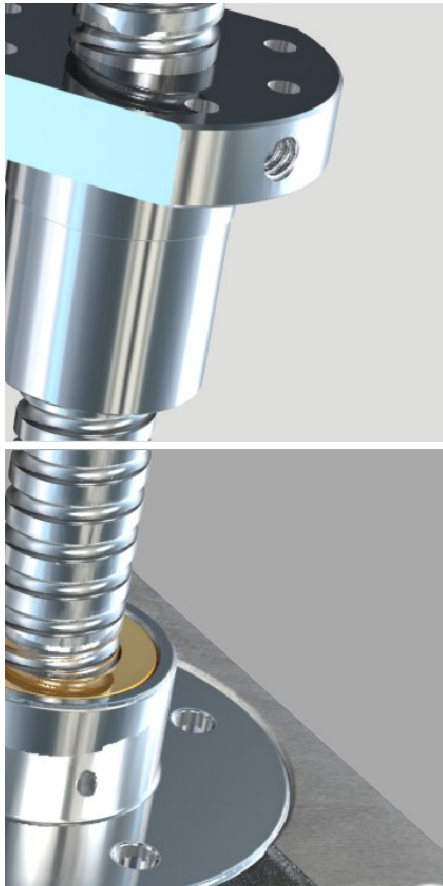
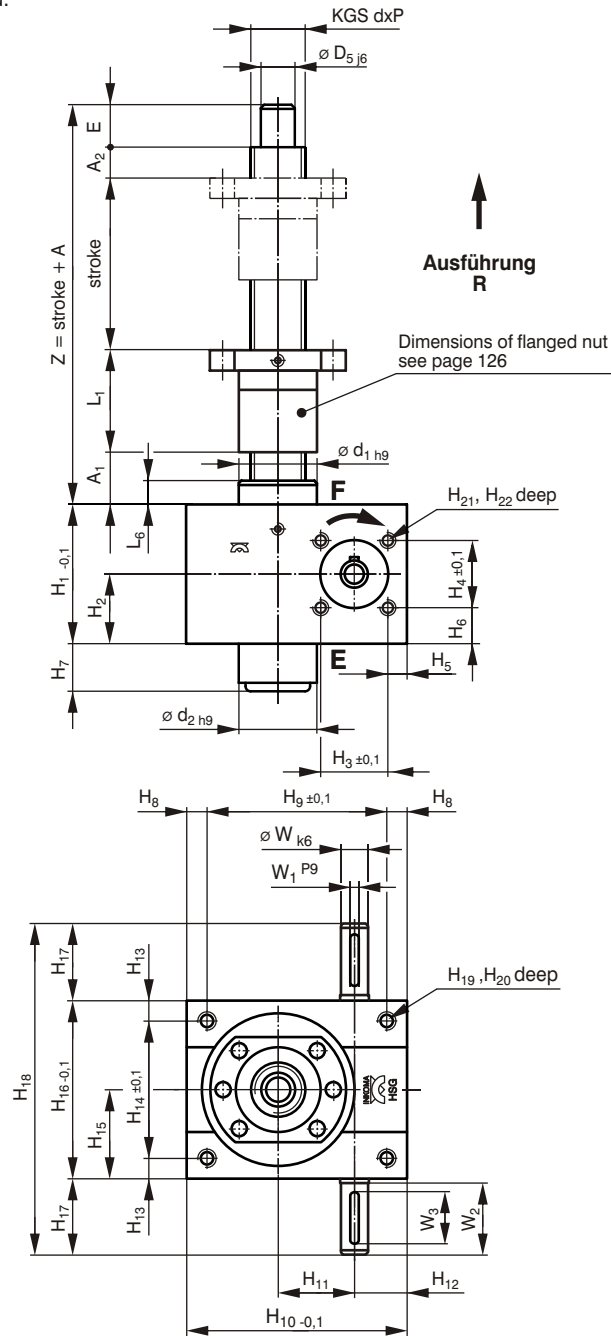

Ordering example:

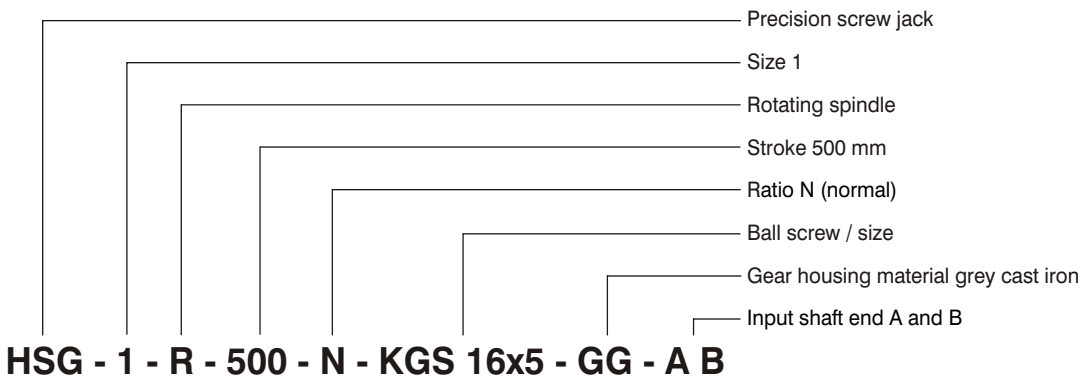

HSG screw jack (cubic design)

Order code	Lifting force F _{dyn.} [kN]	F _{stat.} max. static lifting force ¹⁾ [kN]	Lift per revolution [mm]	Ratio i	Mass [kg]	Dimensions [mm]														
						KGS dxP	D ₅	d ₁	d ₂	A	A ₁	A ₂	E	L ₆	H ₁	H ₂	H ₃	H ₄	H ₅	
						HSG-0-R-stroke-N-KGS-12x5	2,5	2,5	1,25	4:1	0,8	12x5	8	26	26	57	20	10	12	12
HSG-0-R-stroke-L-KGS-12x5	2,5	2,5	0,31	16:1	0,8	12x5	8	26	26	57	20	10	12	12	50	25	25	25	5,5	
HSG-1-R-stroke-N-KGS-16x5	5	5	1,25	4:1	2,4	16x5	12	30	30	95	24	14	15	12	62	31	32	32	8	
HSG-1-R-stroke-L-KGS-16x5	5	5	0,31	16:1	2,4	16x5	12	30	30	95	24	14	15	12	62	31	32	32	8	
HSG-2-R-stroke-N-KGS-20x5	10	10	1,25	4:1	3,4	20x5	15	39	39	125	39	26	20	18,5	75	37,5	35	35	10,5	
HSG-2-R-stroke-N-KGS-25x10	10	10	2,5	4:1	3,4	25x10	15	39	39	138	35	22	20	18,5	75	37,5	35	35	10,5	
HSG-2-R-stroke-L-KGS-20x5	10	10	0,31	16:1	3,4	20x5	15	39	39	125	39	26	20	18,5	75	37,5	35	35	10,5	
HSG-2-R-stroke-L-KGS-25x10	10	10	0,63	16:1	3,4	25x10	15	39	39	138	35	22	20	18,5	75	37,5	35	35	10,5	
HSG-3-R-stroke-N-KGS-32x5	21,5	25	0,83	6:1	6,2	32x5	20	46	46	139	34	25	25	14	82	41	44	44	9	
HSG-3-R-stroke-N-KGS-32x10	25	25	1,67	6:1	6,2	32x10	20	46	46	175	40	25	25	14	82	41	44	44	9	
HSG-3-R-stroke-L-KGS-32x5	21,5	25	0,21	24:1	6,2	32x5	20	46	46	139	34	25	25	14	82	41	44	44	9	
HSG-3-R-stroke-L-KGS-32x10	25	25	0,42	24:1	6,2	32x10	20	46	46	175	40	25	25	14	82	41	44	44	9	
HSG-4-R-stroke-N-KGS-40x5	25,9	50	0,71	7:1	16,5	40x5	25	60	60	176	65	31	30	34	117	58,5	55	55	11,5	
HSG-4-R-stroke-N-KGS-40x10	39,8	50	1,43	7:1	16,5	40x10	25	60	60	197	67	30	30	34	117	58,5	55	55	11,5	
HSG-4-R-stroke-L-KGS-40x5	25,9	50	0,18	28:1	16,5	40x5	25	60	60	176	65	31	30	34	117	58,5	55	55	11,5	
HSG-4-R-stroke-L-KGS-40x10	39,8	50	0,36	28:1	16,5	40x10	25	60	60	197	67	30	30	34	117	58,5	55	55	11,5	
HSG-5-R-stroke-N-KGS-63x10	84,7	100	1,11	9:1	34	63x10	40	85	85	255	60	30	45	40	160	80	70	70	11	
HSG-5-R-stroke-N-KGS-63x20	100	100	2,22	9:1	34	63x20	40	85	85	300	70	35	45	40	160	80	70	70	11	
HSG-5-R-stroke-L-KGS-63x10	84,7	100	0,28	36:1	34	63x10	40	85	85	255	60	30	45	40	160	80	70	70	11	
HSG-5-R-stroke-L-KGS-63x20	100	100	0,56	36:1	34	63x20	40	85	85	300	70	35	45	40	160	80	70	70	11	
HSG-200-R-stroke-N-KGS-80x10	93,4	200	1,00	10:1	57	80x10	55	120	105	280	60	30	70	40	165 ²⁾	82,5 ³⁾	80	80	20	
HSG-200-R-stroke-N-KGS-80x20	135	200	2,00	10:1	57	80x20	55	120	105	335	70	35	70	40	165 ²⁾	82,5 ³⁾	80	80	20	
HSG-200-R-stroke-L-KGS-80x10	93,4	200	0,25	40:1	57	80x10	55	120	105	280	60	30	70	40	165 ²⁾	82,5 ³⁾	80	80	20	
HSG-200-R-stroke-L-KGS-80x20	135	200	0,50	40:1	57	80x20	55	120	105	335	70	35	70	40	165 ²⁾	82,5 ³⁾	80	80	20	

¹⁾ The values for max. load apply only for initial jack selection. The actual permitted lifting force depends on the version of the jack and the operating conditions.

Order code	Dimensions [mm]																				
	H ₆	H ₇	H ₈	H ₉	H ₁₀	H ₁₁	H ₁₂	H ₁₃	H ₁₄	H ₁₅	H ₁₆	H ₁₇	H ₁₈	H ₁₉	H ₂₀	H ₂₁	H ₂₂	W	W ₁	W ₂	W ₃
HSG-0-R-stroke-N-KGS-12x5	12,5	16	6	48	60	20	18	6	38	25	50	21	92	M6	10	M5	5	9	3	20	16
HSG-0-R-stroke-L-KGS-12x5	12,5	16	6	48	60	20	18	6	38	25	50	21	92	M6	10	M5	5	9	3	20	16
HSG-1-R-stroke-N-KGS-16x5	15	17	10	60	80	25	24	10	52	36	72	24	120	M8	12	M5	10	10	3	22	18
HSG-1-R-stroke-L-KGS-16x5	15	17	10	60	80	25	24	10	52	36	72	24	120	M8	12	M5	10	10	3	22	18
HSG-2-R-stroke-N-KGS-20x5	20	21	11	78	100	32	28	11	63	42,5	85	27,5	140	M8	15	M6	10	14	5	25	20
HSG-2-R-stroke-N-KGS-25x10	20	21	11	78	100	32	28	11	63	42,5	85	27,5	140	M8	15	M6	10	14	5	25	20
HSG-2-R-stroke-L-KGS-20x5	20	21	11	78	100	32	28	11	63	42,5	85	27,5	140	M8	15	M6	10	14	5	25	20
HSG-2-R-stroke-L-KGS-25x10	20	21	11	78	100	32	28	11	63	42,5	85	27,5	140	M8	15	M6	10	14	5	25	20
HSG-3-R-stroke-N-KGS-32x5	19	28	12	106	130	45	31	12	81	52,5	105	45	195	M10	15	M8	12	16	5	43	36
HSG-3-R-stroke-N-KGS-32x10	19	28	12	106	130	45	31	12	81	52,5	105	45	195	M10	15	M8	12	16	5	43	36
HSG-3-R-stroke-L-KGS-32x5	19	28	12	106	130	45	31	12	81	52,5	105	45	195	M10	15	M8	12	16	5	43	36
HSG-3-R-stroke-L-KGS-32x10	19	28	12	106	130	45	31	12	81	52,5	105	45	195	M10	15	M8	12	16	5	43	36
HSG-4-R-stroke-N-KGS-40x5	31	37	15	150	180	63	39	15	115	72,5	145	47,5	240	M12	16	M10	12	20	6	45	36
HSG-4-R-stroke-N-KGS-40x10	31	37	15	150	180	63	39	15	115	72,5	145	47,5	240	M12	16	M10	12	20	6	45	36
HSG-4-R-stroke-L-KGS-40x5	31	37	15	150	180	63	39	15	115	72,5	145	47,5	240	M12	16	M10	12	20	6	45	36
HSG-4-R-stroke-L-KGS-40x10	31	37	15	150	180	63	39	15	115	72,5	145	47,5	240	M12	16	M10	12	20	6	45	36
HSG-5-R-stroke-N-KGS-63x10	45	45	17	166	200	71	46	17	131	82,5	165	67,5	300	M20	30	M12	15	25	8	65	56
HSG-5-R-stroke-N-KGS-63x20	45	45	17	166	200	71	46	17	131	82,5	165	67,5	300	M20	30	M12	15	25	8	65	56
HSG-5-R-stroke-L-KGS-63x10	45	45	17	166	200	71	46	17	131	82,5	165	67,5	300	M20	30	M12	15	25	8	65	56
HSG-5-R-stroke-L-KGS-63x20	45	45	17	166	200	71	46	17	131	82,5	165	67,5	300	M20	30	M12	15	25	8	65	56
HSG-200-R-stroke-N-KGS-80x10	42,5	45	25	190 ²⁾	240 ⁴⁾	80	60	25	170 ²⁾	110	220	67,5	355	M30	36	M16	20	30	8	65	56
HSG-200-R-stroke-N-KGS-80x20	42,5	45	25	190 ²⁾	240 ⁴⁾	80	60	25	170 ²⁾	110	220	67,5	355	M30	36	M16	20	30	8	65	56
HSG-200-R-stroke-L-KGS-80x10	42,5	45	25	190 ²⁾	240 ⁴⁾	80	60	25	170 ²⁾	110	220	67,5	355	M30	36	M16	20	30	8	65	56
HSG-200-R-stroke-L-KGS-80x20	42,5	45	25	190 ²⁾	240 ⁴⁾	80	60	25	170 ²⁾	110	220	67,5	355	M30	36	M16	20	30	8	65	56

²⁾ Tolerance ±0,4 ³⁾ Tolerance ±0,2 ⁴⁾ Tolerance ±0,5

HSG screw jack (cubic design)

Flanged nut dimensions

Ball screw spindle - rotating version (R)

INKOMA-flanged nut to DIN 69051, for all normal connections of the screw jack to the moving element.

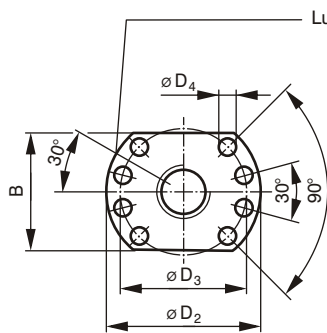
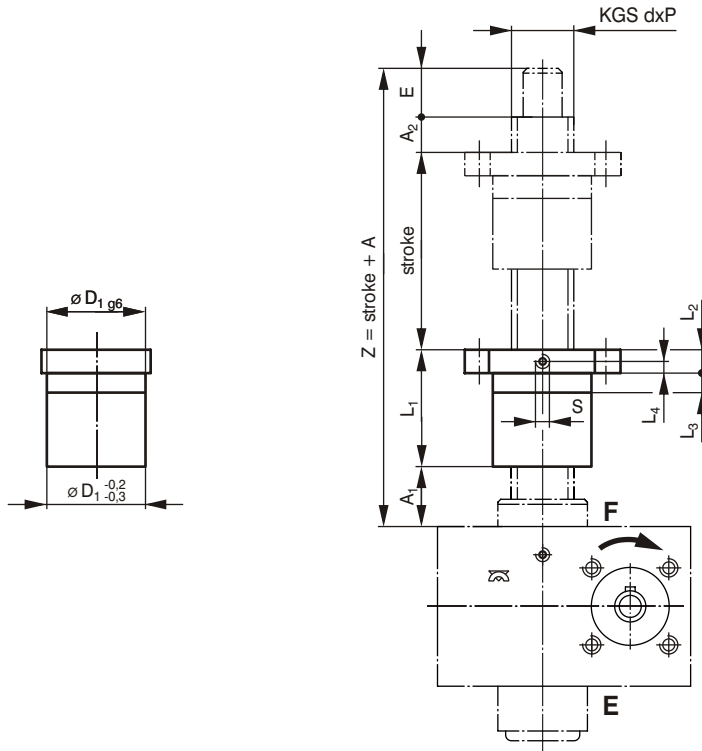

Flanged nut DIN 69051
(hole pattern 1)

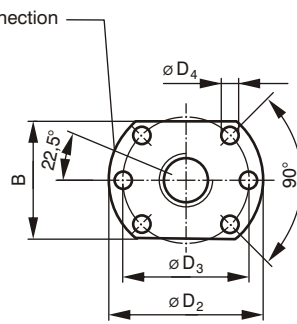

Flanged nut DIN 69051
(hole pattern 2)

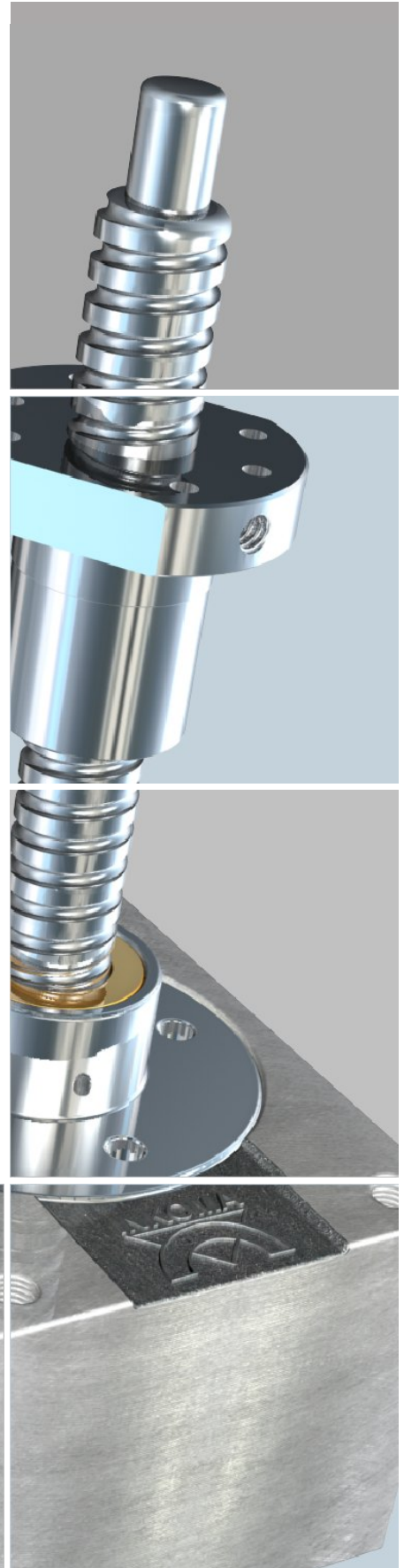

HSG screw jack (cubic design)

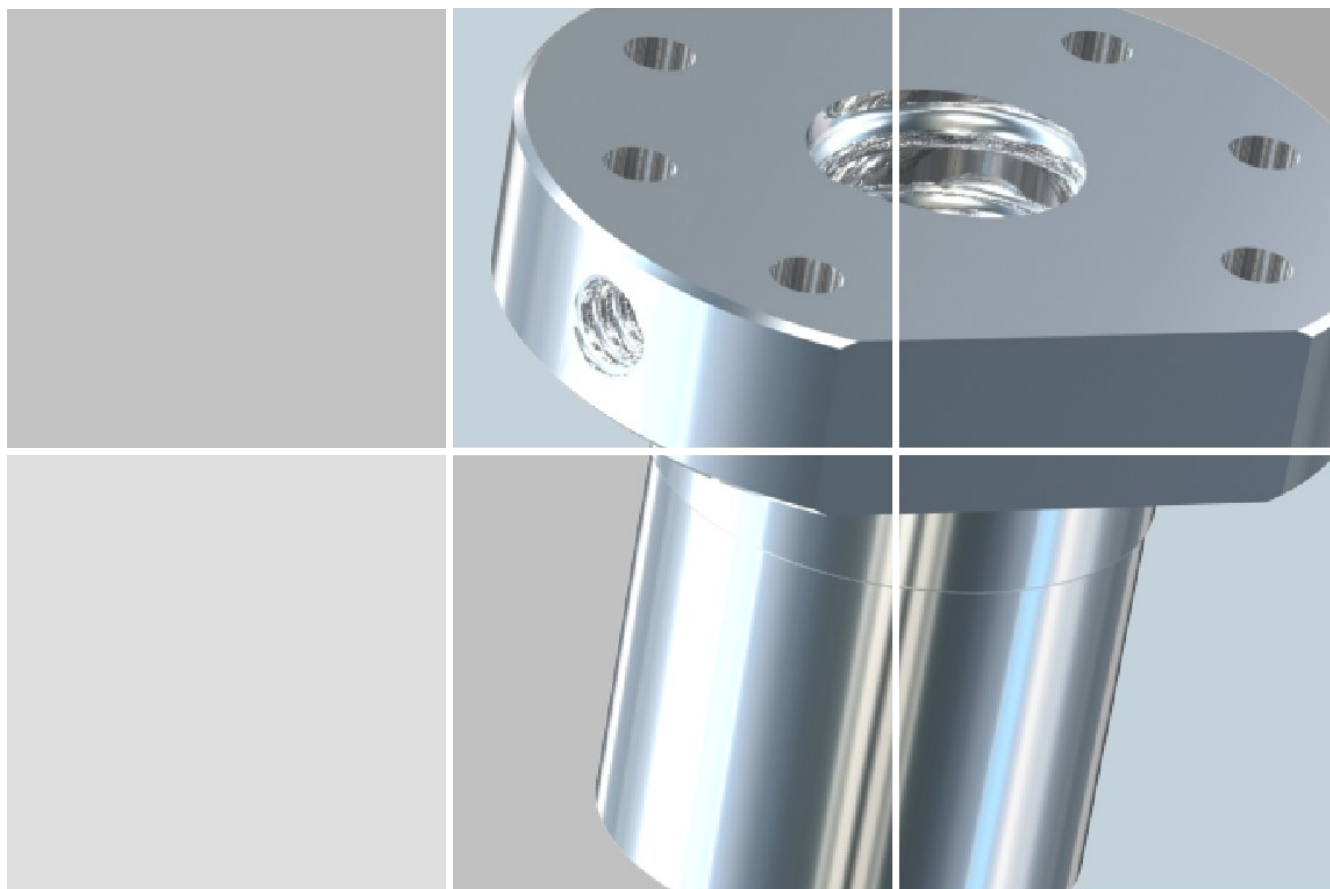

Order code	Hole pattern	Dimensions [mm]														
		KGS dxP	A	A ₁	A ₂	B	D ₁	D ₂	D ₃	D ₄	E	L ₁	L ₂	L ₃	L ₄	S
HSG-0-R-KGS	2	12x5	57	20	10	32	24	46	35	5,5	12	15	10	5	5	M6
HSG-1-R-KGS	2	16x5	95	24	14	40	28	48	38	5,5	15	42	10	10	5	M6
HSG-2-R-KGS	2	20x5	125	39	26	44	36	58	47	6,6	20	40	10	10	5	M6
HSG-2-R-KGS	2	25x10	138	35	22	48	40	62	51	6,6	20	61	10	16	5	M6
HSG-3-R-KGS	2	32x5	139	34	25	62	50	80	65	9	25	55	12	10	6	M6
HSG-3-R-KGS	2	32x10	175	40	25	62	50	80	65	9	25	85	12	16	6	M6
HSG-4-R-KGS	1	40x5	176	65	31	70	63	93	78	9	30	50	14	10	7	M8x1
HSG-4-R-KGS	1	40x10	197	67	30	70	63	93	78	9	30	70	14	16	7	M8x1
HSG-5-R-KGS	1	63x10	255	60	30	95	90	125	108	11	45	120	18	16	9	M8x1
HSG-5-R-KGS	1	63x20	300	70	35	100	95	135	115	13,5	45	150	20	25	10	M8x1
HSG-200-R-KGS	1	80x10	280	60	30	110	105	145	125	13,5	70	120	20	16	10	M8x1
HSG-200-R-KGS	1	80x20	335	70	35	130	125	165	145	13,5	70	160	25	25	12	M8x1

HSG - KSH screw jack (cubic design)

Selection of screw jacks

Examples

In designing screw jack lifting systems it is necessary to establish the operating conditions. The load to be lifted and the stroke length must be determined.

Additional loads, acting non-axially must be taken into account. Following the determination of the number and attitude of the jacks, the load on each individual jack must be calculated. Next determine the drive train for the screw jacks.

The following rules apply for the illustrations below:

- all jacks in these examples have a common direction of rotation
- the number of transmission elements is as small as possible
- the motor position is closest to the most heavily loaded screw jack HSG / KSH

Arrangement examples

Example 1

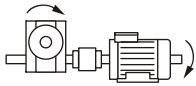

Example 2

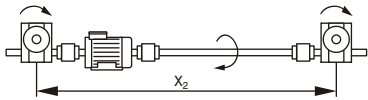

Example 3

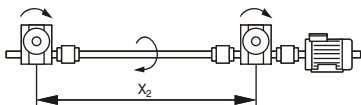

Example 4

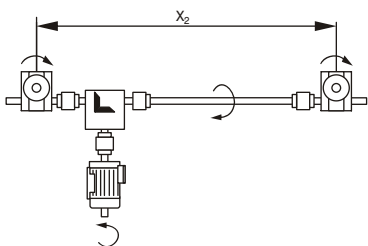

Example 5

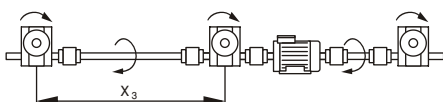

Example 6

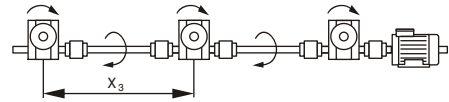

Example 7

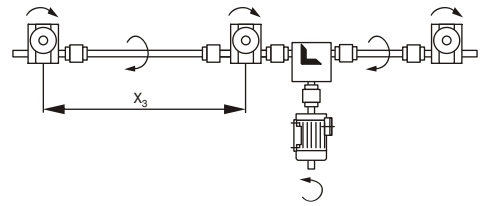

Example 8

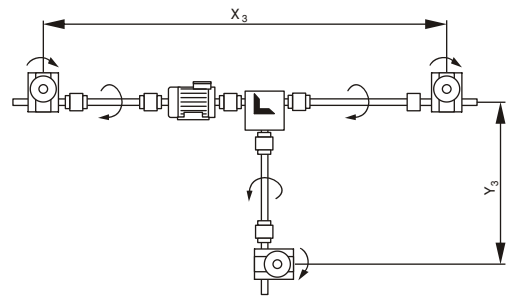

Example 9

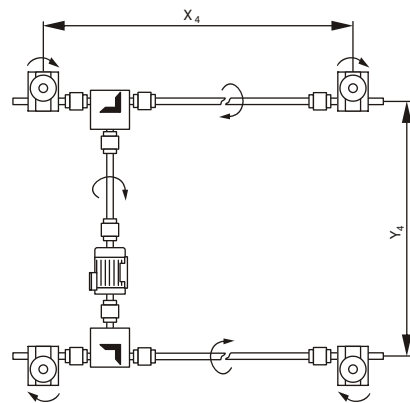

Example 10

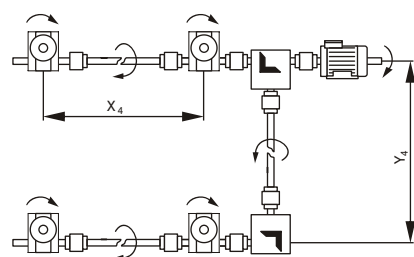

HSG - KSH screw jack (cubic design)

Selection of screw jacks

Arrangement examples

Example 11

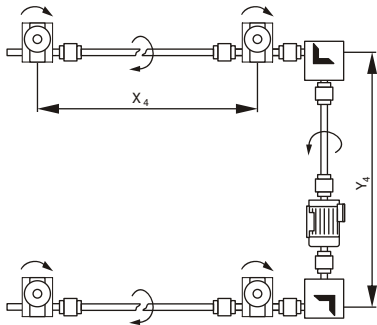

Example 12

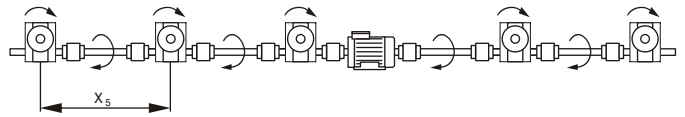

Example 13

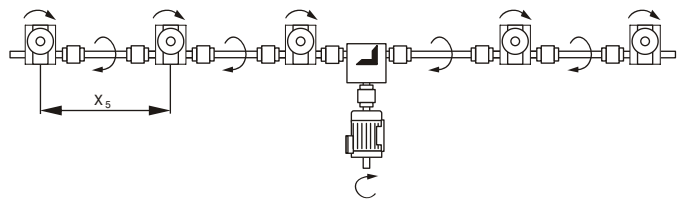

Example 14

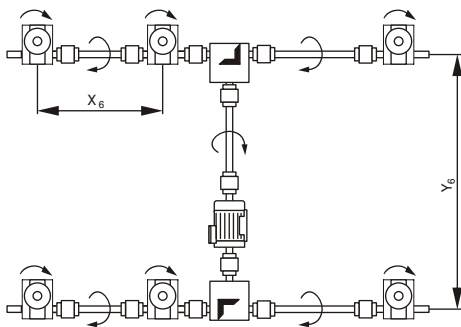

Example 15

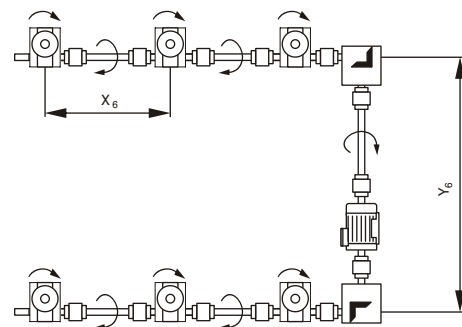

Example 16

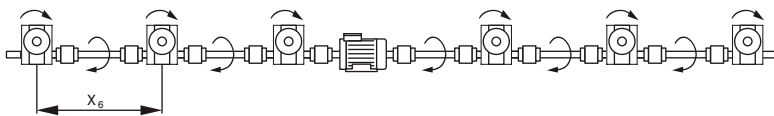

Example 17

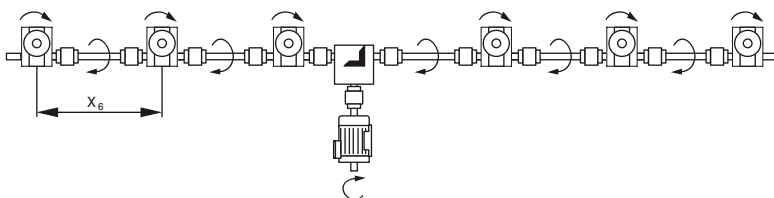

Example 18

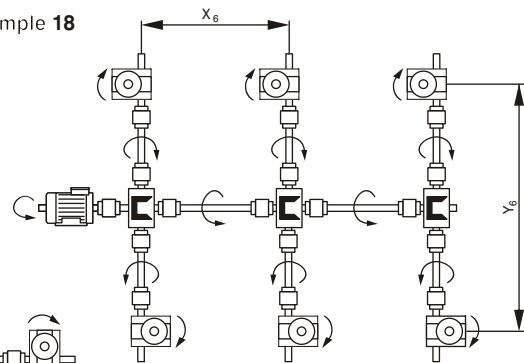

HSG - KSH screw jack (cubic design)

Definition of the applied loads, torques and speeds

F_{eff}	[kN]	effective lifting load of the screw jack
$F_{r \text{ max}}$	[kN]	maximum radial load
$M_{\text{in.}}$	[Nm]	input torque
$M_{\text{br.}}$	[Nm]	braking torque
M_{max}	[Nm]	maximum drive torque
$M_{\text{sp.}}$	[Nm]	torque in the lifting spindle
$n_{\text{in.}}$	[1/min]	input speed
n_2	[1/min]	spindle speed (only for version R)
V_{lift}	[m/min]	lifting speed

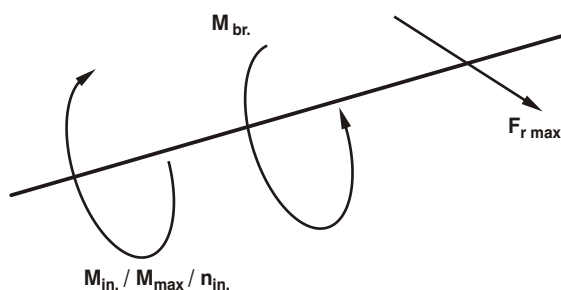
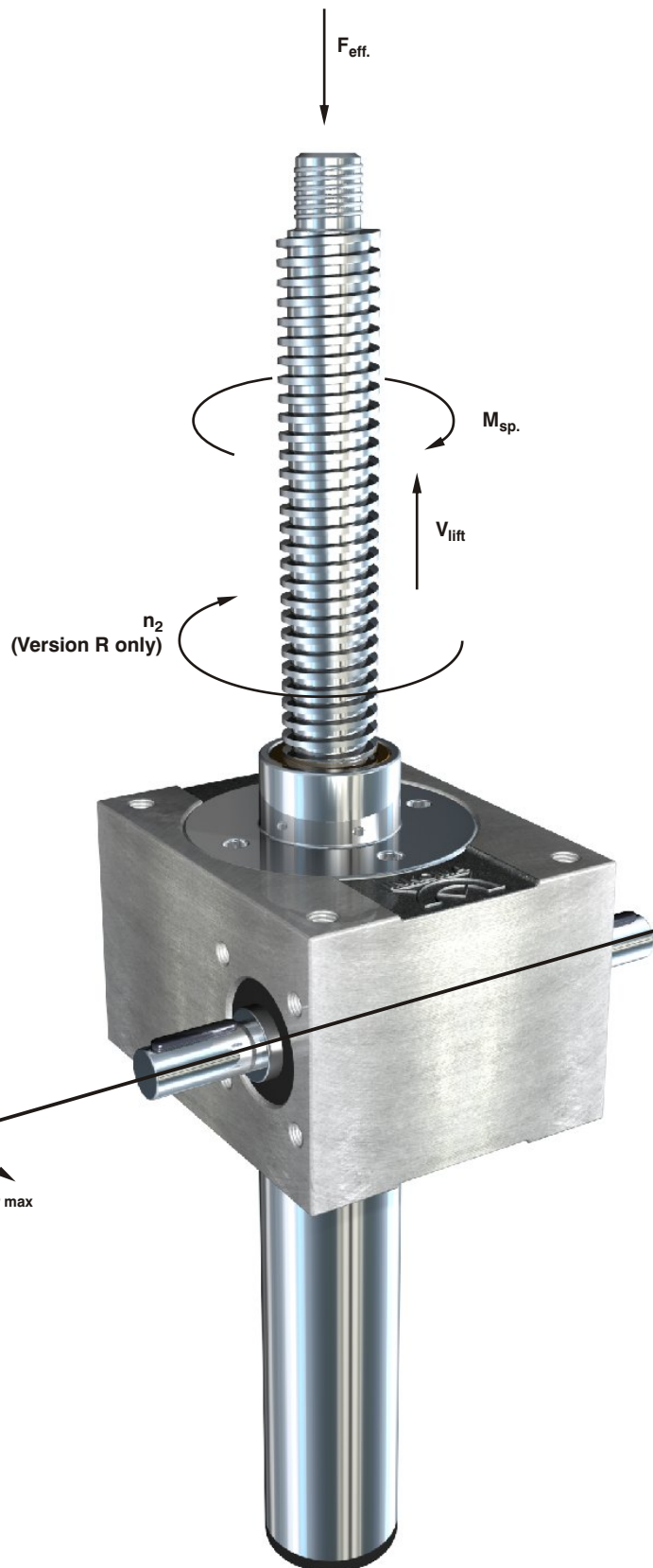

HSG - KSH screw jack (cubic design)

Calculations

Calculation of the duty ED

The duty ED [%/h] is derived from the time in operation (lifting and lowering) and the inactive time between successive operations.

Example:

Lifting		4s					4s
Lowering			2s		2s		4s
Inactive			10s		10s	12s	32s
Total cycle = 40s							
ED per cycle in % = 20%							
Cycles per operating day = 10							

Maximum duty ED [%/h]

If the duty is below 5%/h or the screw jack is only used for minor adjustments the following calculation can be omitted.

Friction causes heat build up in screw jacks during operation. This heat must be dissipated to the atmosphere by radiation and convection. To prevent overheating of the screw jack the effective lifting capacity of the screw jack $P_{lift\ eff.}$ [kNm/min] is limited by the thermal duty capacity ED [%/h].

Method:

1. Determination of the effective lifting capacity $P_{lift\ eff.}$ [kNm/min]

$$P_{lift\ eff.} \text{ [kNm/min]} = F_{eff.} \text{ [kN]} \cdot V_{lift} \text{ [m/min]}$$

2. Temperature factor f_T [-] can be read from the graph.

3. $P_{lift\ eff.}$ [kNm/min] \leq $P_{lift\ max.}$ [kNm/min] $\cdot f_T$ [-]

Explanation:

$P_{lift\ eff.}$	[kNm/min]	effective lifting capacity
$F_{eff.}$	[kN]	effective lifting load of the screw jack
V_{lift}	[m/min]	the maximum lifting speed depends on the input speed to the jack. HSG $n_{max} = 1500$ 1/min KSH $n_{max} = 3000$ 1/min
$P_{lift\ max.}$	[kNm/min]	maximum lifting capacity (see table)
f_T	[-]	temperature factor resulting from the relative duty ED[%/h] at an ambient of 20°C.

Temperature factor f_T [-]

- ① Screw jack with trapezoidal spindle
- ② Screw jack with ball screw spindle

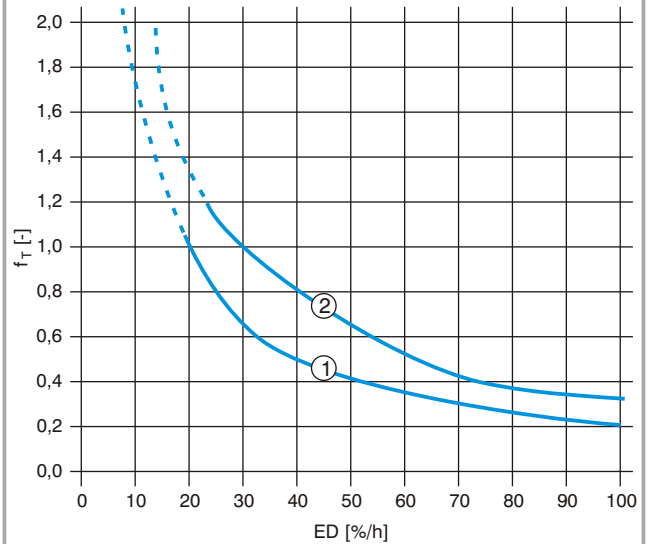

Order code	$P_{lift\ max.}$ [kNm/min]	
	Tr Trapezoidal spindle ¹⁾	KGS Ball screw spindle ²⁾
HSG-0-N	1,7	2,9
HSG-0-L	0,66	1,35
HSG-1-N	2,8	5,3
HSG-1-L	1,43	3,1
HSG-2-N	4,5	9,2
HSG-2-L	1,9	4,45
HSG-3-N	10,1	19,7
HSG-3-L	4,6	10,2
HSG-4-N	20,2	44,2
HSG-4-L	12,0	18,2
HSG-5-N	36,0	78,8
HSG-5-L	14,2	38,5
HSG-200-N	57,0	138,5
HSG-200-L	23,2	66,2
HSG-300-N	72,0	169,0
HSG-300-L	28,3	83,5
HSG-400-N	90,0	-
HSG-400-L	33,0	-
HSG-500-N	104,0	-
HSG-500-L	37,5	-
KSH-1 2:1	27,3	53,8
KSH-1 3:1	24,4	49,2
KSH-2 2:1	59,5	126,3
KSH-2 3:1	48,6	101,1
KSH-3 2:1	73,0	168,7
KSH-3 3:1	58,8	135,2

1) maximum lifting capacity at ED 20 %/h

2) maximum lifting capacity at ED 30 %/h

HSG - KSH screw jack (cubic design)

Calculations

Critical buckling loads on the lifting spindle $F_{crit.}$ [kN]

When loaded in compression lifting spindles are subject to radial buckling. They must therefore be checked for permitted load $F_{perm.}$ [kN] using an installation factor f_k [-].

Method:

1. The critical buckling force $F_{crit.}$ [kN] is read from the table using the spindle size and buckling length L_b [mm].

Note:

The buckling graphs contain a safety factor of 5.

2. Determination of the Installation factor f_k [-] based on the examples shown below.

3. Calculation of the permitted compressive load:

$$F_{perm.} [kN] = F_{crit.} [kN] \cdot f_k [-]$$

4. $F_{eff.} [kN] \leq F_{perm.} [kN]$

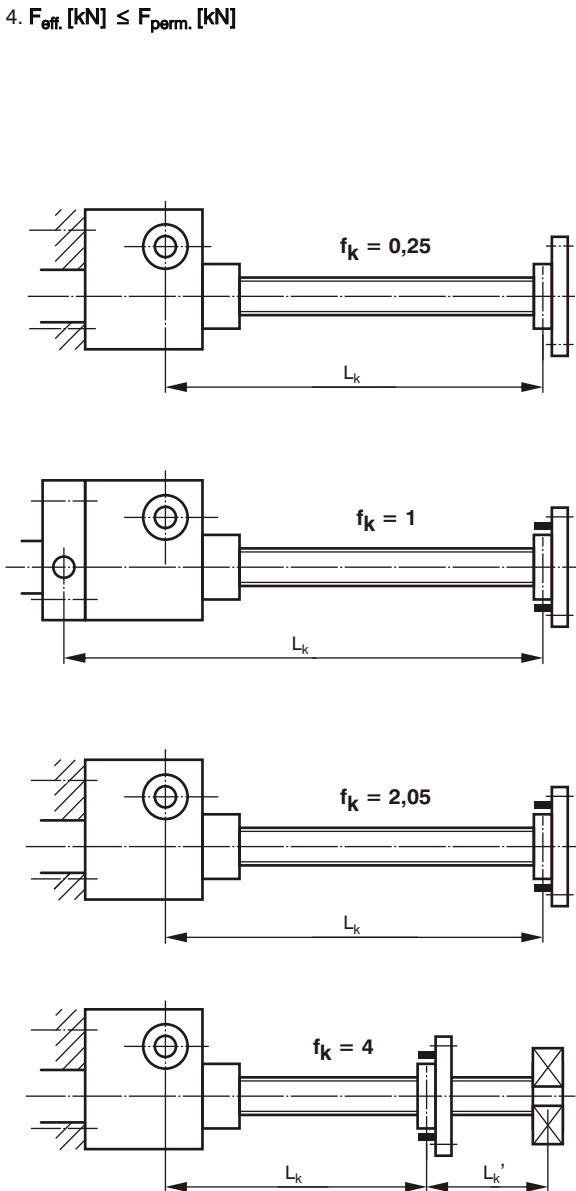
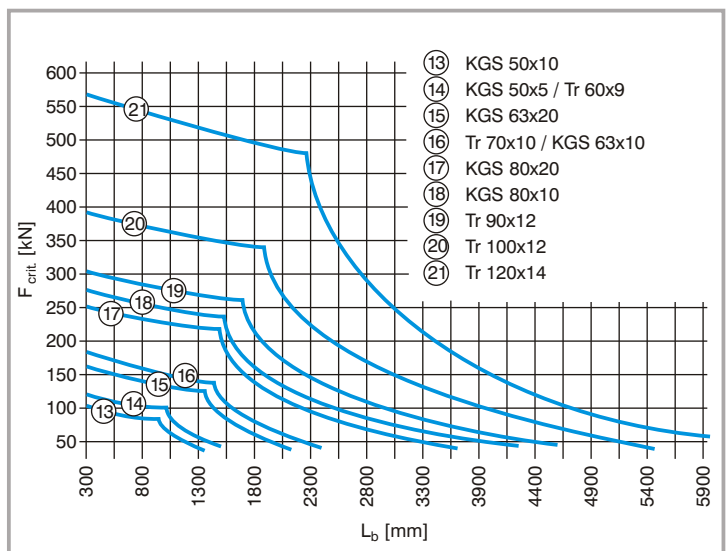
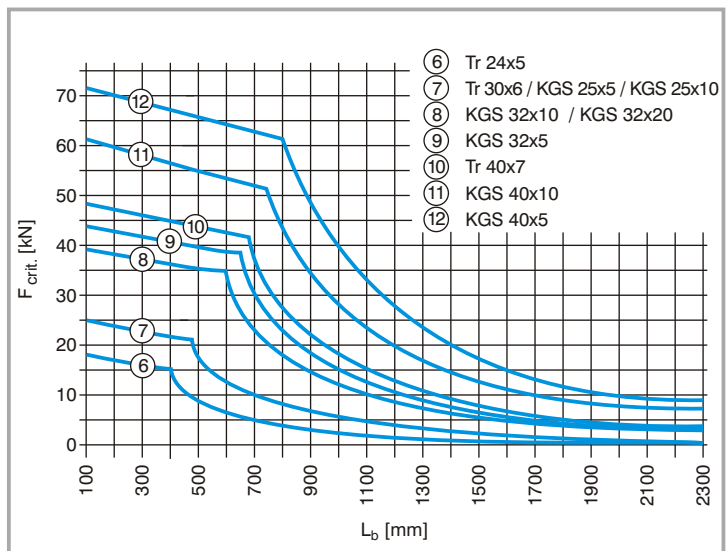
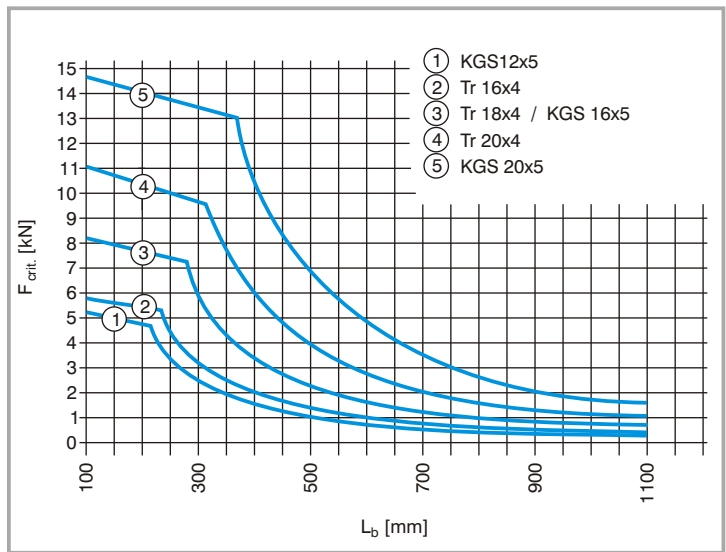

HSG - KSH screw jack (cubic design)

Calculations

Critical spindle speed $n_{crit.}$ - only for rotating version R

Rotating spindles are subject to vibration due to resonance. All rotating spindles should be checked for speed n_2 [1/min] vs permitted speed.

Method:

1. Determination of the spindle speed n_2 [1/min]

$$n_2 \text{ [1/min]} = \frac{V_{lift} \text{ [m/min]} \cdot 1000}{P \text{ [mm]}}$$

2. Obtain the critical spindle speed $n_{crit.}$ [1/min] from the graph. The spindle size and the length L_n [mm] is required.

3. Determination of the permitted spindle speed $n_{perm.}$ [1/min]:

$$n_{perm.} \text{ [1/min]} = 0,8 \cdot n_{crit.} \text{ [1/min]} \cdot f_n \text{ [-]}$$

4. The permitted spindle speed $n_{perm.}$ [1/min] must be greater than the actual spindle speed n_2 [1/min]:

$$n_{perm.} > n_2$$

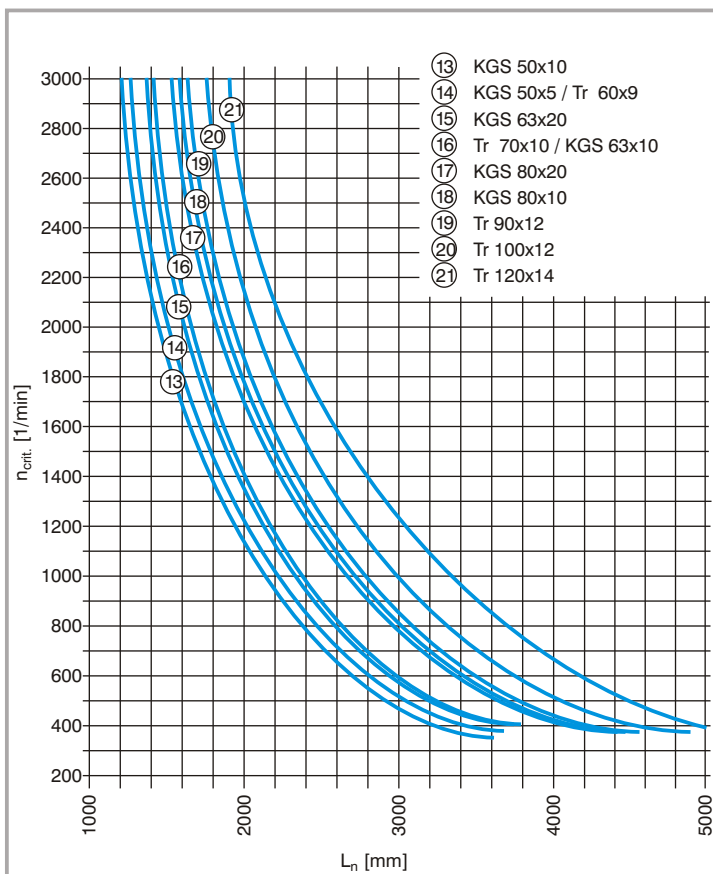
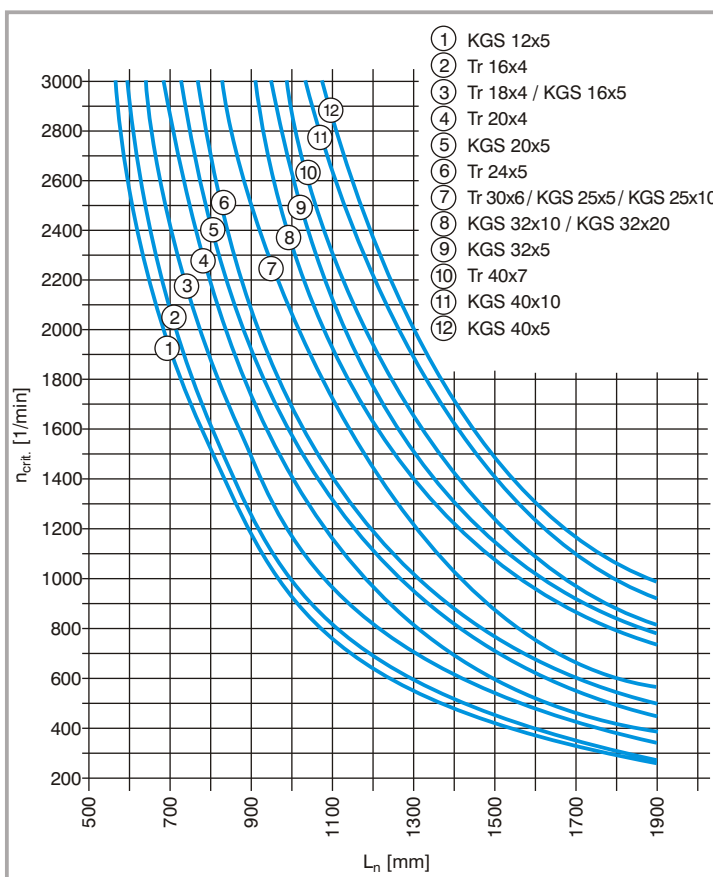
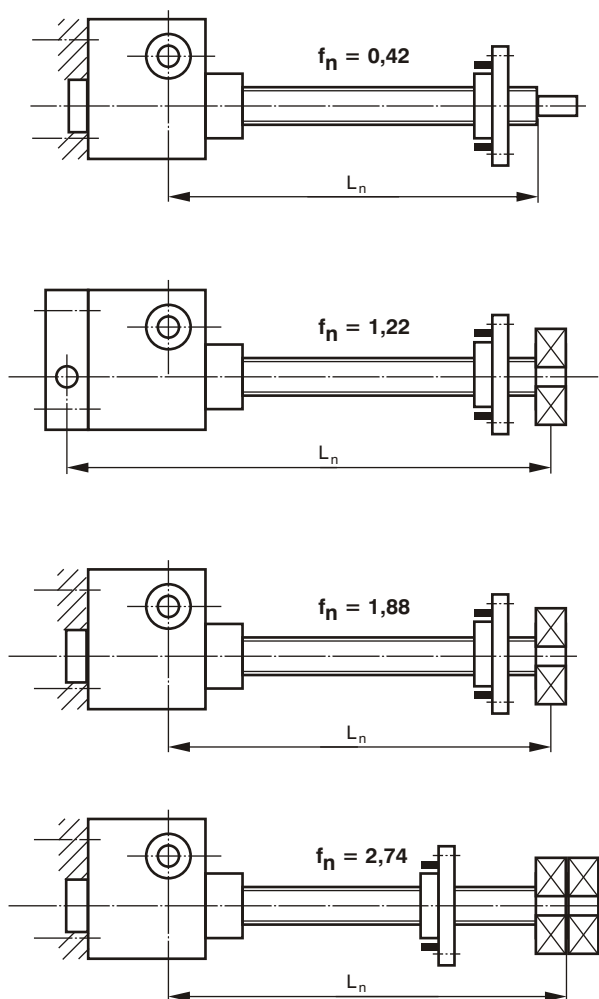

HSG - KSH screw jack (cubic design)

Calculations

Torque in the lifting spindle M_{sp} . [Nm]

The torque in the lifting spindle M_{sp} . [Nm], refers to the torque which the spindle applies to the mounting flange or clevis in versions S and SA.

For version R, the torque in the lifting spindle, M_{sp} . [Nm], refers to the torque which the spindle applies to the running nut.

$$M_{sp} \text{ [Nm]} = F_{eff} \text{ [kN]} \cdot f_H \text{ [mm]}$$

Trapezoidal spindle	f_H [mm]	
	$\mu=0,1$ lubricated	$\mu=0,3$ not lubricated
Tr 16x4	1,40	2,97
Tr 18x4	1,51	3,29
Tr 20x4	1,61	3,61
Tr 24x5	1,96	4,35
Tr 30x6	2,42	10,21
Tr 40x7	3,09	7,11
Tr 60x9	4,43	10,51
Tr 70x10	5,10	12,22
Tr 90x12	6,44	15,62
Tr 100x12	6,97	17,22
Tr 120x14	8,31	20,63

Braking torque M_{br} . [Nm]

Ball screw spindles (KGS) and depending on the lead, certain trapezoidal spindles (Tr), are not self locking. It is therefore necessary, in such cases, to specify a brake motor. The required braking torque can be calculated as follows:

$$M_{br} \text{ [Nm]} = \frac{F_{eff} \text{ [kN]} \cdot P \text{ [mm]} \cdot \eta_{tot} \text{ [-]}}{2 \cdot \pi \cdot i \text{ [-]}}$$

Ball screw spindle	f_H [mm]
KGS 12x5	1,6
KGS 16x5	1,6
KGS 20x5	1,6
KGS 25x5	1,6
KGS 25x10	3,2
KGS 32x5	1,6
KGS 32x10	3,2
KGS 32x20	6,4
KGS 40x5	1,6
KGS 40x10	3,2
KGS 40x20	6,4
KGS 50x5	1,6
KGS 63x10	3,2
KGS 63x20	6,4
KGS 80x10	3,2
KGS 80x20	6,4

Explanation:

M_{sp} .	[Nm]	torque in the lifting spindle
F_{eff} .	[kN]	effective lifting load of the screw jack
M_{br} .	[Nm]	braking torque
f_H	[mm]	factor to compensate for spindle geometry and frictional losses (see table)
η_{tot} .	[-]	total working efficiency (see table page 135)
P	[mm]	pitch of spindle
i	[-]	screw jack ratio

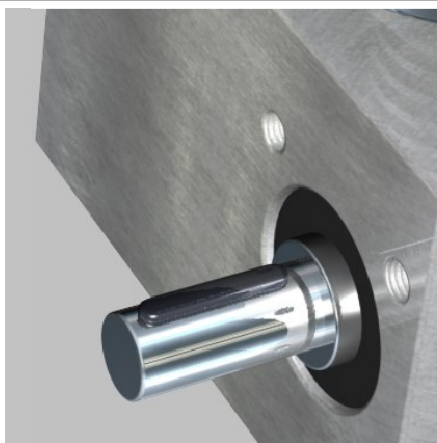
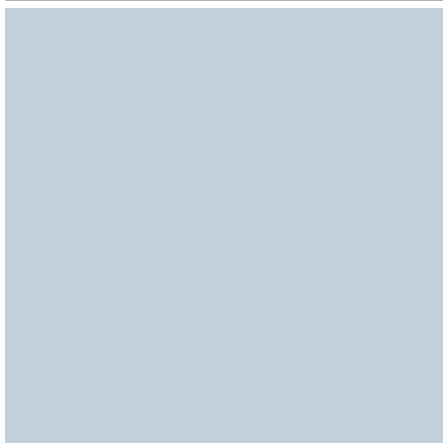
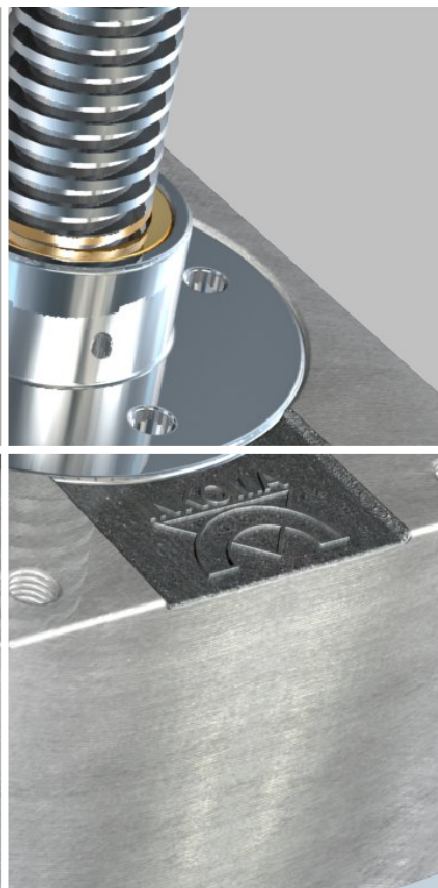

HSG - KSH screw jack (cubic design)

Calculations

Input torque M_{in} . [Nm] for each screw jack

To facilitate calculation of the required input torque M_{in} . [Nm] use factor f_M [mm]. This compensates for the overall efficiency η_{tot} . [-], the spindle pitch P [mm] and the ratio i [-].

$$M_{in} \text{ [Nm]} = F_{eff} \text{ [kN]} \cdot f_M \text{ [mm]} + M_0 \text{ [Nm]}$$

Determination of the factor f_M [mm]:

$$f_M \text{ [mm]} = \frac{P \text{ [mm]}}{2 \cdot \pi \cdot \eta_{tot} \text{ [-]} \cdot i \text{ [-]}}$$

Explanation:

M_{in}	[Nm]	input torque
F_{eff}	[kN]	effective lifting load of the screw jack
f_M	[mm]	factor for all standard screw jacks (see table)
M_0	[Nm]	no load torque (see table)
P	[mm]	spindle pitch
η_{tot}	[-]	total working efficiency
i	[-]	screw jack ratio

KSH-1 - KSH-3					
Order code	i [-]	Typ d x P	f_M [mm]	M_0 [Nm]	η_{tot} [-]
KSH-1 2:1	2	Tr 24 x 5	1,16	1,70	0,34
KSH-1 2:1	2	KGS 25 x 5	0,55	1,60	0,72
KSH-1 2:1	2	KGS 25 x 10	1,11	1,60	0,72
KSH-1 3:1	3	Tr 24 x 5	0,79	1,60	0,33
KSH-1 3:1	3	KGS 25 x 5	0,38	1,50	0,70
KSH-1 3:1	3	KGS 25 x 10	0,75	1,50	0,70
KSH-2 2:1	2	Tr 40 x 7	1,67	2,20	0,33
KSH-2 2:1	2	KGS 32 x 10	1,11	2,10	0,72
KSH-2 2:1	2	KGS 32 x 20	2,21	2,10	0,72
KSH-2 2:1	2	KGS 40 x 5	0,55	2,10	0,72
KSH-2 2:1	2	KGS 40 x 10	1,11	2,10	0,72
KSH-2 2:1	2	KGS 40 x 20	2,21	2,10	0,72
KSH-2 3:1	3	Tr 40 x 7	1,14	2,10	0,33
KSH-2 3:1	3	KGS 32 x 10	0,75	2,00	0,70
KSH-2 3:1	3	KGS 32 x 20	1,51	2,00	0,70
KSH-2 3:1	3	KGS 40 x 5	0,38	2,00	0,70
KSH-2 3:1	3	KGS 40 x 10	0,75	2,00	0,70
KSH-2 3:1	3	KGS 40 x 20	1,51	2,00	0,70
KSH-3 2:1	2	Tr 60 x 9	2,41	4,20	0,30
KSH-3 2:1	2	KGS 63 x 10	1,11	4,10	0,72
KSH-3 2:1	2	KGS 63 x 20	2,21	4,10	0,72
KSH-3 3:1	3	Tr 60 x 9	1,64	4,10	0,29
KSH-3 3:1	3	KGS 63 x 10	0,75	4,10	0,70
KSH-3 3:1	3	KGS 63 x 20	1,51	4,10	0,70

HSG-0 - HSG-500					
Order code	i [-]	Typ d x P	f_M [mm]	M_0 [Nm]	η_{tot} [-]
HSG-0-N	4	Tr 16 x 4	0,46	0,03	0,35
HSG-0-N	4	KGS 12 x 5	0,33	0,02	0,61
HSG-0-L	16	Tr 16 x 4	0,12	0,02	0,32
HSG-0-L	16	KGS 12 x 4	0,06	0,02	0,63
HSG-1-N	4	Tr 18 x 4	0,49	0,04	0,32
HSG-1-N	4	KGS 12 x 4	0,26	0,04	0,62
HSG-1-N	4	KGS 16 x 5	0,32	0,04	0,62
HSG-1-L	16	Tr 18 x 4	0,15	0,04	0,27
HSG-1-L	16	KGS 12 x 5	0,10	0,03	0,52
HSG-1-L	16	KGS 16 x 5	0,10	0,03	0,52
HSG-2-N	4	Tr 20 x 4	0,52	0,12	0,31
HSG-2-N	4	KGS 16 x 5	0,32	0,11	0,62
HSG-2-N	4	KGS 20 x 5	0,32	0,11	0,62
HSG-2-N	4	KGS 25 x 10	0,65	0,11	0,62
HSG-2-L	16	Tr 20 x 4	0,15	0,11	0,26
HSG-2-L	16	KGS 16 x 5	0,10	0,10	0,52
HSG-2-L	16	KGS 20 x 5	0,10	0,10	0,52
HSG-2-L	16	KGS 25 x 10	0,19	0,10	0,52
HSG-3-N	6	Tr 30 x 6	0,55	0,16	0,29
HSG-3-N	6	KGS 25 x 5	0,23	0,15	0,58
HSG-3-N	6	KGS 25 x 10	0,46	0,15	0,58
HSG-3-N	6	KGS 32 x 5	0,32	0,15	0,58
HSG-3-N	6	KGS 32 x 10	0,46	0,15	0,58
HSG-3-L	24	Tr 30 x 6	0,17	0,14	0,24
HSG-3-L	24	KGS 25 x 5	0,07	0,14	0,48
HSG-3-L	24	KGS 25 x 10	0,14	0,14	0,48
HSG-3-L	24	KGS 32 x 5	0,07	0,14	0,48
HSG-3-L	24	KGS 32 x 10	0,14	0,14	0,48
HSG-4-N	7	Tr 40 x 7	0,58	0,37	0,27
HSG-4-N	7	KGS 32 x 5	0,19	0,35	0,59
HSG-4-N	7	KGS 32 x 10	0,38	0,35	0,59
HSG-4-N	7	KGS 40 x 5	0,19	0,35	0,59
HSG-4-N	7	KGS 40 x 10	0,38	0,35	0,59
HSG-4-L	28	Tr 40 x 7	0,19	0,26	0,21
HSG-4-L	28	KGS 32 x 5	0,06	0,25	0,46
HSG-4-L	28	KGS 32 x 10	0,12	0,25	0,46
HSG-4-L	28	KGS 40 x 5	0,06	0,25	0,46
HSG-4-L	28	KGS 40 x 10	0,12	0,25	0,46
HSG-5-N	9	Tr 60 x 9	0,73	0,90	0,22
HSG-5-N	9	KGS 40 x 5	0,17	0,85	0,53
HSG-5-N	9	KGS 40 x 10	0,33	0,85	0,53
HSG-5-N	9	KGS 50 x 5	0,17	0,85	0,53
HSG-5-N	9	KGS 50 x 10	0,33	0,85	0,53
HSG-5-N	9	KGS 63 x 10	0,33	0,85	0,53
HSG-5-N	9	KGS 63 x 20	0,67	0,85	0,53
HSG-5-L	36	Tr 60 x 9	0,23	0,55	0,17
HSG-5-L	36	KGS 40 x 5	0,05	0,51	0,42
HSG-5-L	36	KGS 40 x 10	0,11	0,51	0,42
HSG-5-L	36	KGS 50 x 5	0,05	0,51	0,42
HSG-5-L	36	KGS 50 x 10	0,11	0,51	0,42
HSG-5-L	36	KGS 63 x 10	0,11	0,51	0,42
HSG-5-L	36	KGS 63 x 20	0,21	0,51	0,42
HSG-200-N	10	Tr 70 x 10	0,77	1,30	0,21
HSG-200-N	10	KGS 80 x 10	0,31	1,15	0,52
HSG-200-N	10	KGS 80 x 20	0,61	1,15	0,52
HSG-200-L	40	Tr 70 x 10	0,24	0,96	0,17
HSG-200-L	40	KGS 80 x 10	0,10	0,90	0,42
HSG-200-L	40	KGS 80 x 20	0,19	0,90	0,42
HSG-300-N	12	Tr 90 x 12	0,87	1,50	0,18
HSG-300-L	48	Tr 90 x 12	0,27	1,10	0,15
HSG-400-N	12	Tr100 x 12	1,03	1,72	0,16
HSG-400-L	48	Tr100 x 12	0,29	1,31	0,14
HSG-500-N	14	Tr120 x 14	1,00	2,10	0,16
HSG-500-L	56	Tr120 x 14	0,29	1,69	0,14



HSG - KSH screw jack (cubic design)

Calculations

Total input torque $M_{tot.}$ [Nm]

The total torque $M_{tot.}$ [Nm] required for the system comprises the lifting load torque, plus losses due to flexible couplings, cardans, support bearings and bevel gearboxes.

The following example shows the derivation of the total torque $M_{tot.}$ [Nm].

$$M_{tot.} = \left(\frac{M_{in.1}}{\eta_{\text{cardan shaft}}} + \frac{M_{in.2}}{\eta_{\text{cardan shaft}}} \right) \cdot \frac{1}{\eta_k}$$

Note:

If a bevel gearbox with a ratio i_k [-] of greater than 1 is used then the torque and input speed must be modified accordingly.

Important:

The breakaway torque of the system can be considerably higher than the calculated input torque. This applies particularly to systems with poor efficiency and long idle periods.

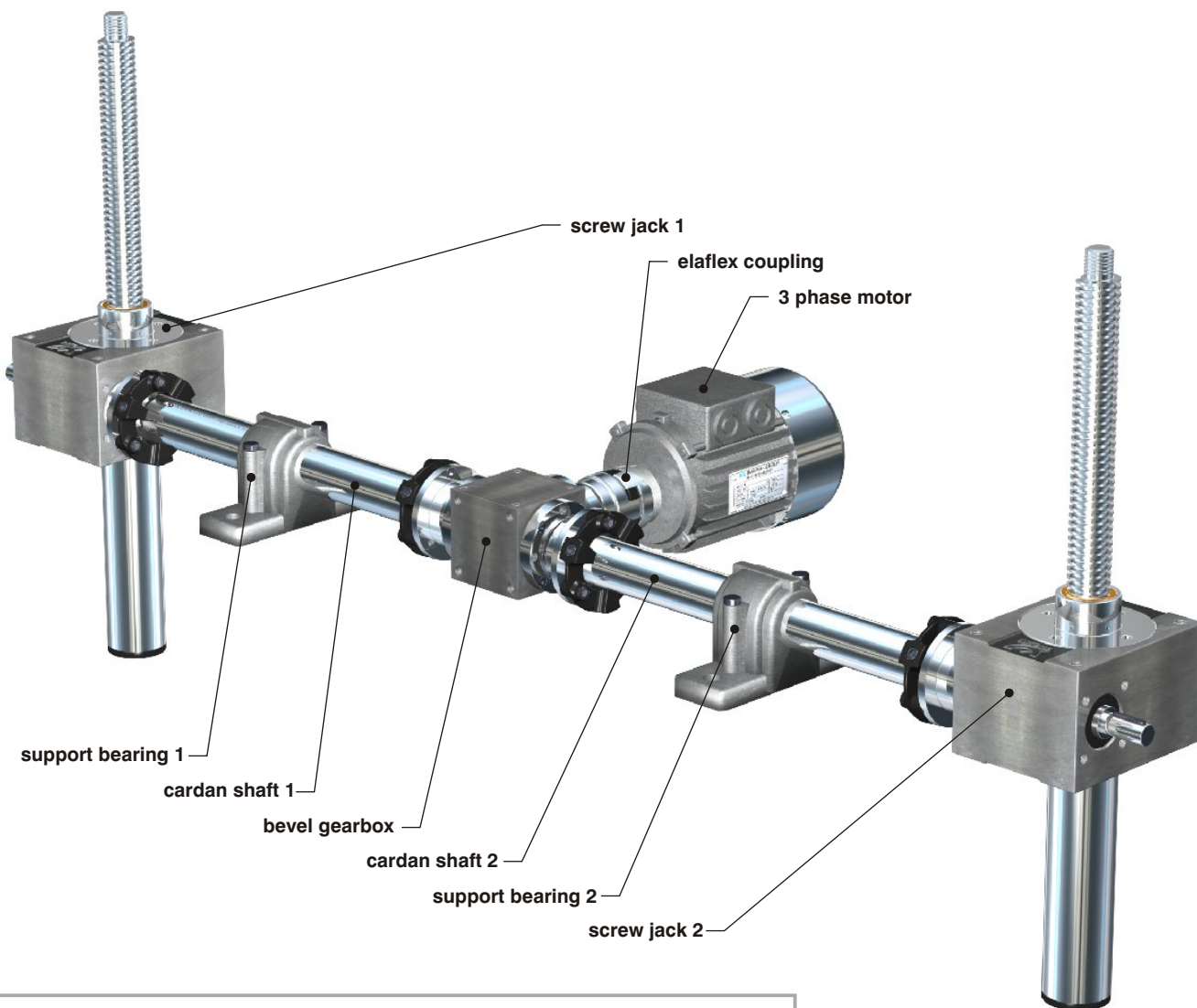

Explanation:

$M_{tot.}$	[Nm]	total input torque
$M_{in.1}$	[Nm]	input torque for screw jack 1
$M_{in.2}$	[Nm]	input torque for screw jack 2
$\eta_{\text{cardan shaft}}$	[-]	efficiency of cardan shaft with support bearing (dependent on the length and the number of support bearings ca. 0.75 to 0.95)
η_k	[-]	efficiency of bevel gearbox (ca. 0.9)

HSG - KSH screw jack (cubic design)

Calculations

Input speed n_{in} . [1/min]

The necessary input speed n_{in} . [1/min] for a specified lifting speed V_{lift} [m/min] is determined as follows:

$$n_{in} \text{ [1/min]} = \frac{V_{lift} \text{ [m/min]} \cdot 1000}{P \text{ [mm]}} \cdot i \text{ [-]}$$

Important:

The input speed should not exceed the maximum allowable.

HSG: $n_{in, max} = 1500$ 1/min

KSH: $n_{in, max} = 3000$ 1/min

Input power P_{in} . [kW]

The required input power P_{in} . [kW] for a specified lifting system is determined as follows:

$$P_{in} \text{ [kW]} = \frac{M_{tot} \text{ [Nm]} \cdot n_{in} \text{ [1/min]}}{9550}$$

Selection of the motor

The required motor can be selected from the input power P_{in} . [kW] and the input speed n_{in} . [1/min].

Notes about motor selection:

- The motor power selected should be adequate to overcome the break away torque of the system which can be considerably higher than the calculated input torque. This relates particularly to systems where there is poor efficiency and long idle periods.
- Following selection of the drive motor it should be checked whether the transmission elements and the screw jacks may be overloaded by the selected motor.
For maximum input torque M_{max} . [Nm] see the adjacent table.
- When using ball screw spindles (KGS) and, depending on the lead certain trapezoidal spindles (Tr), it is necessary to specify a Brake Motor since these systems are not self locking.
- In conditions of heavy vibration the self locking capability of some screw jacks can no longer be guaranteed. In such cases, or where it is possible that such vibration may occur, a brake motor must be specified.
- To minimise the possibility of damage to the screw jack system, end of travel limit switches should be fitted. E.g. limit switch with roller follower or inductive proximity switch.

Actual lifting speed $V_{lift act}$. [m/min]

In most cases the required input speed differs from the motor speed.

The actual lifting speed $V_{lift act}$. [m/min], which will be achieved based on motor speed n_{motor} . [1/min] is calculated as follows:

$$V_{lift act} \text{ [m/min]} = \frac{n_{motor} \text{ [1/min]} \cdot P \text{ [mm]}}{1000 \cdot i \text{ [-]}}$$

Explanation:

n_{in} .	[1/min]	input speed
V_{lift}	[m/min]	required lifting speed
P	[mm]	spindle pitch
i	[-]	screw jack ratio
P_{in} .	[kW]	input power
M_{tot} .	[Nm]	total input torque
$V_{lift act}$.	[m/min]	actual lifting speed
n_{motor}	[1/min]	motor speed

Maximum input torques M_{max} . [Nm]

Maximum radial load on the screw jack input shaft $F_{r max}$ [kN]

Order code	M_{max} [Nm]	$F_{r max}$ [kN]
HSG-0	1,5	0,07
HSG-1	3,4	0,1
HSG-2	7,1	0,2
HSG-3	18	0,3
HSG-4	38	0,5
HSG-5	93	0,8
HSG-200	178	1,3
HSG-300	280	1,5
HSG-400	390	2,3
HSG-500	570	3,1
KSH-1 / 2:1	16	0,3
KSH-1 / 3:1	12	0,3
KSH-2 / 2:1	60	0,6
KSH-2 / 3:1	40	0,6
KSH-3 / 2:1	200	2,5
KSH-3 / 3:1	135	2,5



HSG - KSH screw jack (cubic design)

Gear housing material

Selection table

Gear housings for INKOMA-screw jacks are manufactured from the best possible materials. Alongside the standard materials there are a number of other options.

If the adjacent table does not contain the material you require, please ask.

- - standard
- - option
- - not possible

Screw jack size	Al 1)	GG 2)	Inox / VA 3)	St 4)
HSG - 0	●	—	○	—
HSG - 1	○	●	○	—
HSG - 2	○	●	○	—
HSG - 3	○	●	○	—
HSG - 4	○	●	○	—
HSG - 5	—	●	○	—
HSG - 200	—	●	○	—
HSG - 300	—	○	○	●
HSG - 400	—	○	○	●
HSG - 500	—	○	○	●
KSH - 1	—	●	—	—
KSH - 2	—	●	—	—
KSH - 3	—	●	—	—

1) AlCuMgPb F34

2) HSG 1-5 GG-28, HSG -200 GGG-40, KSH-1, KSH-2, KSH-3 GG-25

3) 1.4305

4) St 52-3

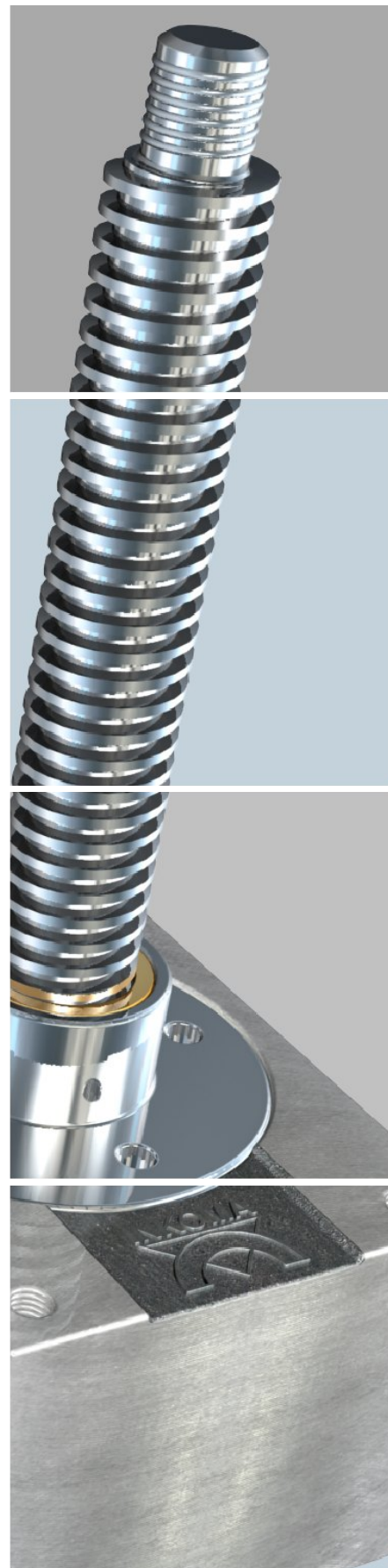

HSG - KSH screw jack (cubic design)

Installation and maintenance

Assembly

To achieve the simplest installation, machined mounting surfaces with adequately dimensioned tapped holes should be provided.

Important:

It should be ensured, wherever possible, that spindle nut fixing screws are compressively loaded.

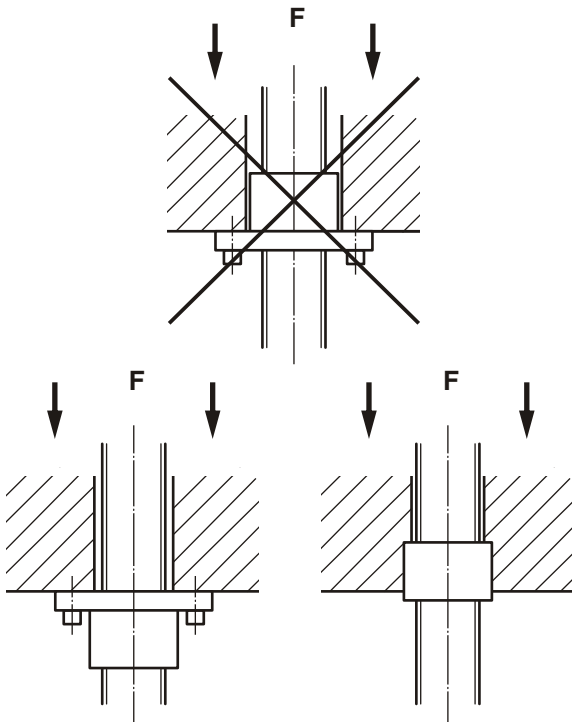

The screw jack should be aligned using a spirit level. Parallel alignment between the lifting system and the guide mechanism must be carefully checked.

Screw jacks systems should be checked for twisting and for tight spots. To check this the lifting system should be actuated by hand over the entire stroke. The force required should be light and even.

The direction of rotation of the individual screw jacks should carefully checked.

Before test running the spindle(s) must be cleaned and if possible sprayed with an aerosol grease lubricant over the entire stroke length.

When test running:

1. Check the function and position of any limit switches.
2. Test the lifting system initially without load if possible.
3. Increase the load incrementally, checking for any hot spots and for gearbox temperature rise.
4. Check the tightness of all screwed connections.

Important:

Do not exceed the permitted loads, duty and input speeds.

Failure to observe this will invalidate your guarantee.

Maintenance of HSG-0 to HSG-5

The spindle should be regularly cleaned and re-lubricated. Every 700 operating hours or every 18 months the grease in the gear housing should be replaced.

1. Dismount the screw jack and clean
2. Disassemble the spindle and spindle protection tube (only for translating spindle)
3. Remove locking screw for gear housing cover
4. Wash out the gear housing and components with a suitable wash medium
5. Refill with **grease** according to the adjacent table

When maintaining the screw jack the wear on the spindle should also be checked.

In addition the clearance between the spindle and nut should be checked. The limiting values for clearance are shown in the table.

If the limiting value is exceeded the screw jack must be overhauled. Return to our factory for repair may be necessary. After checking, re-assemble the unit in reverse order. The bearing cover should be tightened then loosened. Then the **tightening torque** shown in the table should be applied to the bearing cover. Check that the screw jack can be rotated easily and without axial clearance.

Order code	Grease quantity [kg]	max. axial play [mm]	Tightening torque ¹⁾ [Nm]
HSG-0	0,012	0,8	3
HSG-1	0,05	1	5
HSG-2	0,09	1	9
HSG-3	0,14	1,5	13
HSG-4	0,45	1,75	32
HSG-5	0,72	2,25	60

¹⁾ Bearing cover assembly

Recommended greases:

The screw jack is supplied with Klüber MICROLUBE GB 0. The following greases are also suitable:

- DEA Orona FGEPO
- ESSO Fibrax EP 370
- Molycote LM 770/0

HSG - KSH screw jack (cubic design)

Questionnaire

Accessories for rotating version (R)

Tensile load, dynamic kN 

Tensile load, static kN 

Compressive load, dynamic kN 

Compressive load, static kN 

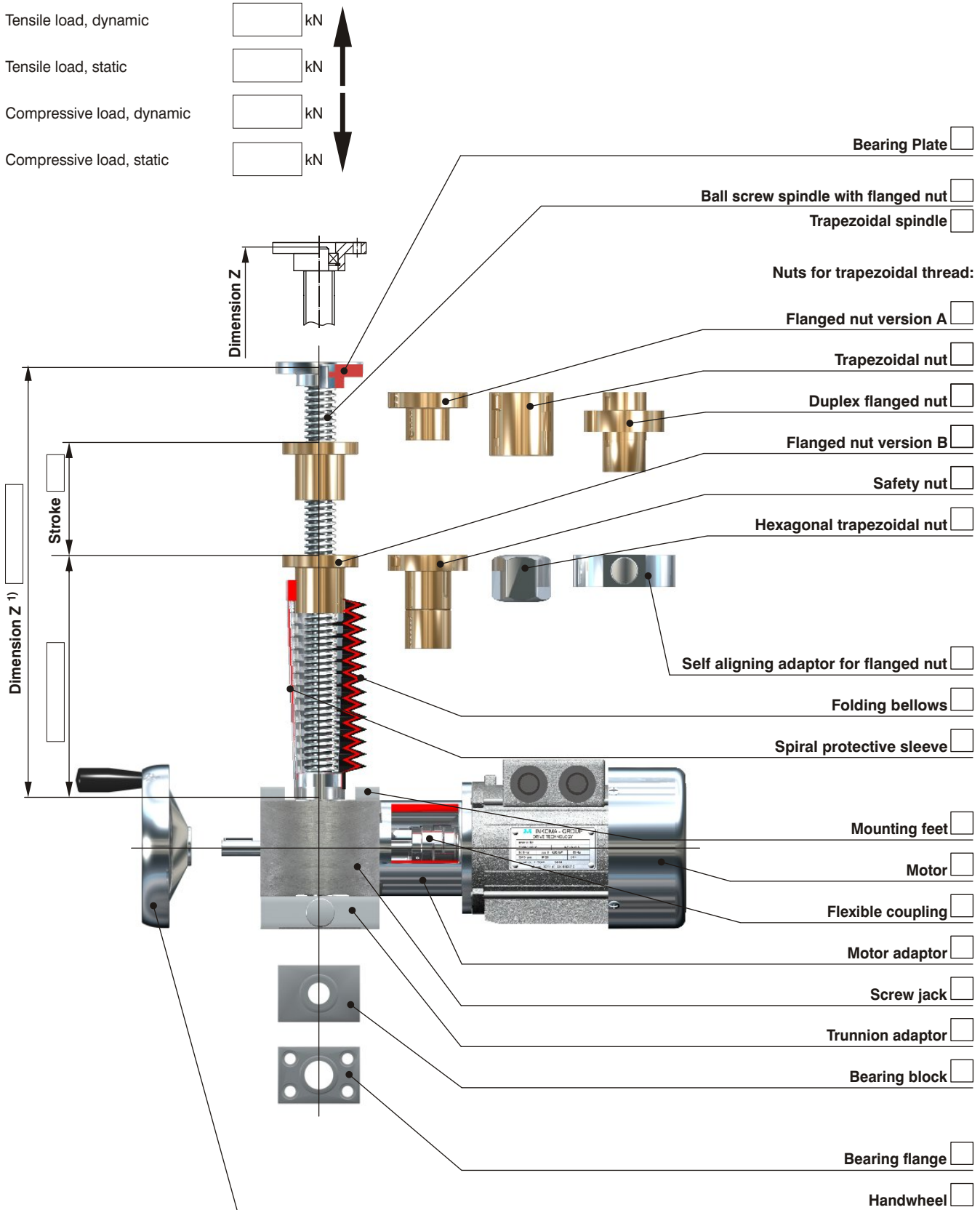

Dimensions:
 Dimension Z
 Stroke
 Dimension Z ¹⁾

Accessories:

- Bearing Plate
- Ball screw spindle with flanged nut
- Trapezoidal spindle
- Nuts for trapezoidal thread:
 - Flanged nut version A
 - Trapezoidal nut
 - Duplex flanged nut
 - Flanged nut version B
 - Safety nut
 - Hexagonal trapezoidal nut
- Self aligning adaptor for flanged nut
- Folding bellows
- Spiral protective sleeve
- Mounting feet
- Motor
- Flexible coupling
- Motor adaptor
- Screw jack
- Trunnion adaptor
- Bearing block
- Bearing flange
- Handwheel

¹⁾ Dimension Z = Distance from the housing upper surface to the spindle end (1-2 mm allowance from mounting face).

HSG - KSH screw jack (cubic design)

Questionnaire

Accessories for translating version (S, SA, SV, SVA)

Tensile load, dynamic	<input type="text"/>	kN	↑
Tensile load, static	<input type="text"/>	kN	
Compressive load, dynamic	<input type="text"/>	kN	↓
Compressive load, static	<input type="text"/>	kN	

Dimension Z₁²⁾

Dimension Z₁¹⁾

Stroke

Dimension Z

- Rod end bearing
- Clevis
- Mounting flange
- Trapezoidal spindle
- Ball screw spindle
- Folding bellows
- Spiral protective sleeve
- Rotation prevention
- Mounting feet
- Flexible coupling
- Motor
- Motor adaptor
- Screw jack
- Trunnion adaptor
- Protective tube
- Setting ring
- Travel limiter, linear cam
- Limit switch with roller follower
- Bearing block
- Bearing flange
- Handwheel

1) Dimension Z = Distance from the housing upper surface to the spindle end (1-2 mm allowance from mounting face).
 2) Dimension Z₁ = Gear housing upper surface to centre line of connecting link